

MDrive® Linear Actuator

Compact, integrated all-in-one linear motion systems

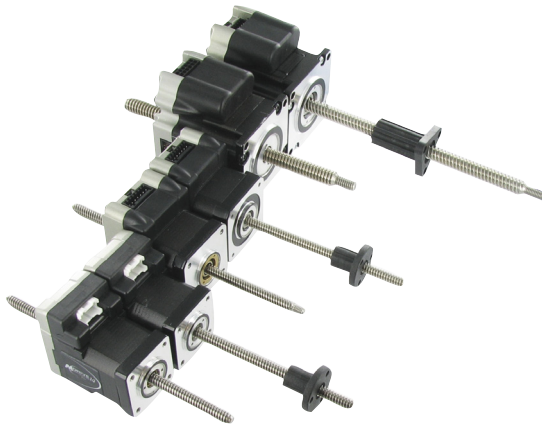

MDrive 23 Plus Linear Actuator
Step/direction input



MDrive® Plus Linear Actuator with step/direction input
non-captive and external shaft styles

Presentation

The MDrive® Plus Linear Actuator with step/direction input is an integrated product that combines a stepper motor linear actuator with mechanicals and electronics to form a single, compact system. It features a 1.8° 2-phase stepper motor linear actuator with on-board control electronics. Step/direction signals of a master controller, e.g. a motion controller, or A/B signals of an encoder, are converted directly into rotary-to-linear motion. This eliminates the need for belts and pulleys, rack and pinion, hydraulics, pneumatics or other mechanical system.

Settings for MDrive Plus Linear Actuators with step/direction input may be changed on-the-fly or downloaded and stored in nonvolatile memory using the IMS SPI Motor Interface software provided. This eliminates the need for external switches or resistors. Parameters are changed via an SPI port.

Application areas

The MDrive Plus Linear Actuator with step/direction input is ideal for machine builders who want an optimized stepper motor linear actuator with on-board electronics. The integrated electronics of the MDrive product reduces the potential for problems due to electrical noise by eliminating the cable between motor and drive.

These compact, powerful and cost effective linear motion control solutions deliver unsurpassed smoothness and performance that will reduce system cost, design and assembly time for a large range of applications.

Features

- Highly integrated microstepping drive and high torque 1.8° 2-phase stepper motor linear actuator
 - Non-captive or external shaft style
 - Load limit up to 200 lbs
 - Precision rolled lead screws
- Advanced current control for exceptional performance and smoothness
- Single supply: from +12 up to +75 VDC
- Cost effective
- Extremely compact
- 20 microstep resolutions up to 51,200 steps per rev including: Degrees, Metric, Arc Minutes
- Optically isolated input options:
 - Universal +5 to +24 VDC signals, sourcing or sinking
 - Differential +5 VDC signals
- Automatic current reduction
- Configurable:
 - Motor run/hold current
 - Motor direction via direction input
 - Microstep resolution
 - Clock type: step and direction, quadrature, step up and step down, clockwise and counterclockwise
 - Programmable digital filtering for clock and direction inputs
- Setup parameters may be switched on-the-fly
- Numerous connector interface choices
- Available options:
 - Externally-mounted encoder (1)
 - Drive Protection Module
- Graphical user interface (GUI) provided for quick and easy parameter setup

(1) Only available for External shaft linear actuators.

General specifications					
			MDrive 14	MDrive 17	MDrive 23
Input power	Voltage	VDC	12 to 48	12 to 48	12 to 75
	Current maximum (1)	amp	1	2	2
Maximum thrust (2)	Non-captive shaft	lbs	50	50	200
		kg	22	22	91
	External shaft with general purpose nut	lbs	25	25	60
		kg	11	11	27
	External shaft with anti-backlash nut	lbs	5	5	25
kg	2	2	11		
Maximum repeatability	General purpose	inch	0.005		
		mm	0.127		
	Anti-backlash (3)	inch	0.0005		
		mm	0.0127		
Thermal	Operating temp non-condensing	Heat sink	-40° to +85°C		
		Motor	-40° to +100°C		
Isolated input	Universal	Voltage range: +5 to +24 VDC sourcing or sinking step clock, direction and enable			
	Differential	Voltage range: +5 VDC clockwise and counterclockwise			
Motion	Digital filter range	50 nS to 12.9 μS (10 MHz to 38.8 kHz)			
	Clock types	Step/direction, quadrature, step up/step down, clockwise/counterclockwise			
	Step frequency	2 MHz default / 5 MHz maximum			
	Microstep resolution	Number of settings	20		
		Steps per revolution	200, 400, 800, 1000, 1600, 2000, 3200, 5000, 6400, 10000, 12800, 20000, 25000, 25600, 40000, 50000, 51200, 36000 (0.01 deg/μstep), 21600 (1 arc minute/μstep), 25400 (0.001 mm/μstep)		

Setup parameters (4)				
SPI communication	Function	Range	Units	Default
MHC	Motor hold current	0 to 100	percent	5
MRC	Motor run current	1 to 100	percent	25
MSEL	Microstep resolution	1, 2, 4, 5, 8, 10, 16, 25, 32, 50, 64, 100, 108, 125, 127, 128, 180, 200, 250, 256	μsteps per full step	256
DIR	Motor direction override	0/1	—	CW
HCDT	Hold current delay time	0 or 2 – 65535	mSec	500
CLK TYPE	Clock type	Step/Dir, Quadrature, Up/Down, CW/CCW	—	Step/Dir
CLK IOF	Clock and direction filter	50 nS to 12.9 μS (10 MHz to 38.8 kHz)	nS (MHz)	200 nS (2 MHz)
USER ID	User ID	Customizable	1–3 characters	IMS
EN ACT	Enable active	High/Low	—	High

(1) Actual power supply current will depend on voltage and load.

(2) Performance data for maximum force/load is based on a static load and will vary with a dynamic load.

(3) Only applicable for External shaft linear actuator with anti-backlash nut.

(4) All parameters are set using the supplied IMS SPI Motor Interface GUI and may be changed on-the-fly. An optional Communication Converter is recommended with first orders.



See User Manual for complete details: www.imshome.com/manuals.html

MDrive® Plus Linear Actuator

Step/direction input

Dimensions in inches (mm)

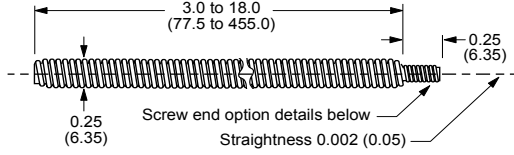

MDrive 14 and MDrive 17 screw dimensions

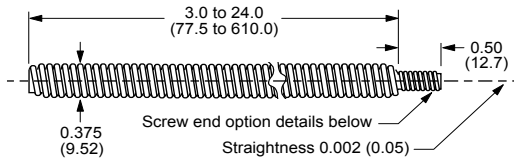

MDrive 23 screw dimensions

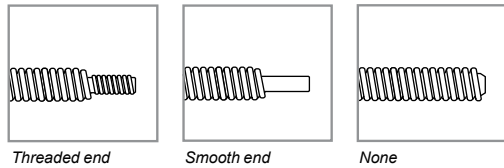

Screw specifications

Material

MDrive Linear Actuator precision rolled lead screws are designed specifically for motion control applications to deliver maximum life and quiet operation. Corrosion resistant and non-magnetic, screws are manufactured from premium grade stainless steel.

Coating

An optional Teflon® screw coating is available for smooth operation and extended life.

Length

Length (1)	MDrive 14 and MDrive 17		MDrive 23	
	minimum	maximum	minimum	maximum
inches	3.0	18.0	3.0	24.0
mm	77.5	455.0	77.5	610.0

(1) Screw lengths are available in 0.1" (2.5mm) increments.

Lead/pitch options

Screw	travel	MDrive 14 and MDrive 17		MDrive 23	
		per revolution	per full step	per revolution	per full step
Screw G	inches	—	—	0.3750	0.001875
	mm	—	—	9.525	0.0476
Screw A	inches	0.250	0.00125	0.200	0.001
	mm	6.350	0.0317	5.08	0.0254
Screw B	inches	0.125	0.00063	0.1670	0.000835
	mm	3.175	0.0158	4.233	0.0212
Screw C	inches	0.063	0.00031	—	—
	mm	1.588	0.0079	—	—
Screw D	inches	0.031	0.00016	0.0833	0.0004165
	mm	0.794	0.0040	2.116	0.0106

End options

Threaded	metric end	MDrive 14 and MDrive 17	MDrive 23
		M4 x 0.7 mm thread to within 0.03"/0.76 mm of shoulder	M6 x 1.0 mm thread to within 0.03"/0.76 mm of shoulder
Smooth	inches	Ø 0.1967 ±0.001	Ø 0.2362 ±0.001
	mm	Ø 5 ±0.003	Ø 6 ±0.003
None		—	—

Load limit

Non-captive shaft (2)	lbs	MDrive 14 and MDrive 17	MDrive 23	
		50 (3)	200	
External shaft	kg	22 (3)	91	
	General purpose nut	lbs	25	60
		kg	11	27
	Anti-backlash nut	lbs	5	25
kg		2	11	

(2) Performance data for maximum force/load is based on a static load and will vary with a dynamic load.

(3) Screw D has a load limit of 10 lbs/4.5 kg. Heavier loads will degrade screw life. Consult factory for alternative.

Calculating length

■ Non-captive shaft products

Screw length = [mounting surface plate thickness] + [desired stroke length] + [•]

- MDrive 14 = 1.4" / 35.6 mm
- MDrive 17 = 1.4" / 35.6 mm
- MDrive 23 = 1.8" / 45.7 mm

■ External shaft products

Available stroke length = [screw length] – [nut length] – [mounting surface plate thickness]

Nut specifications

MDrive Linear Actuators with external shaft employ a nut which moves axially along the threaded shaft as the screw rotates. Two nut styles are available: general purpose and anti-backlash. While anti-backlash nuts provide higher accuracy and low drag torque, general purpose nuts are rated for higher load limits but lack wear compensation.

MDrive 14 and MDrive 17 nuts

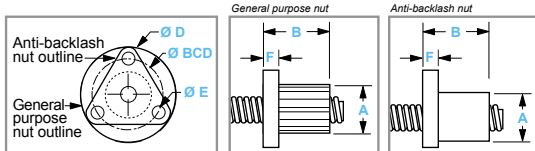

MDrive 23 nuts

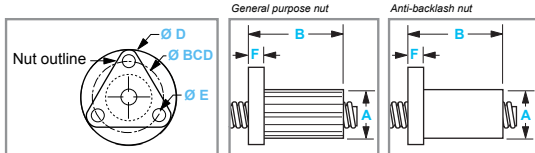

Dimensions and performance

		MDrive 14 and MDrive 17		MDrive 23	
	nut type	general purpose	anti-backlash	general purpose	anti-backlash
A	inches	0.50	0.50	0.71	0.82
	mm	12.7	12.7	18.0	20.8
B	inches	0.75	0.9 max	1.50	1.875 max
	mm	19.1	22.86 max	38.1	47.63 max
D	inches	1.0	1.0	1.5	1.5
	mm	25.4	25.4	38.1	38.1
E	inches	0.14	0.143	0.20	0.20
	mm	3.6	3.63	5.08	5.08
F	inches	0.15	0.18	0.20	0.20
	mm	3.81	4.57	5.08	5.08
BCD	inches	0.75	0.75	1.125	1.125
	mm	19.1	19.1	28.6	28.6
Load limit	lbs	25	5	60	25
	kg	11	2	27	11
Drag torque		free wheeling	< 1.0 oz-in	free wheeling	1 to 3
			< 0.7 N-cm		

MDrive® 23 Plus Linear Actuator

Step/direction input

– Non-captive shaft – mechanical specifications, dimensions in inches (mm)

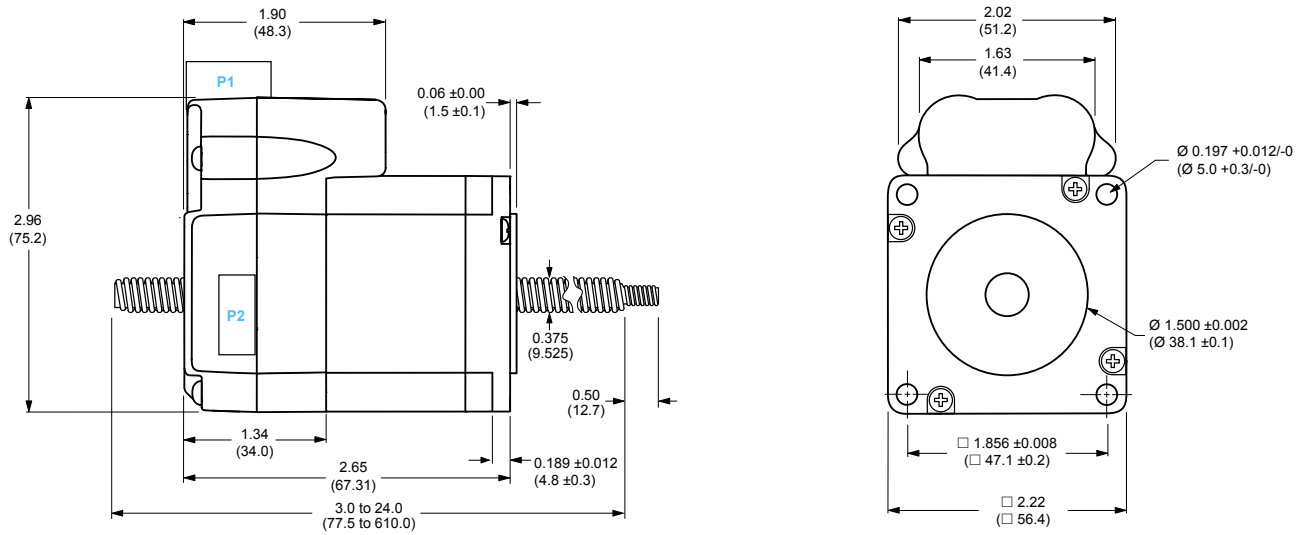

Unsupported loads and side loading are not recommended for non-captive shaft MDrive® linear actuator products.

– External shaft – mechanical specifications, dimensions in inches (mm)

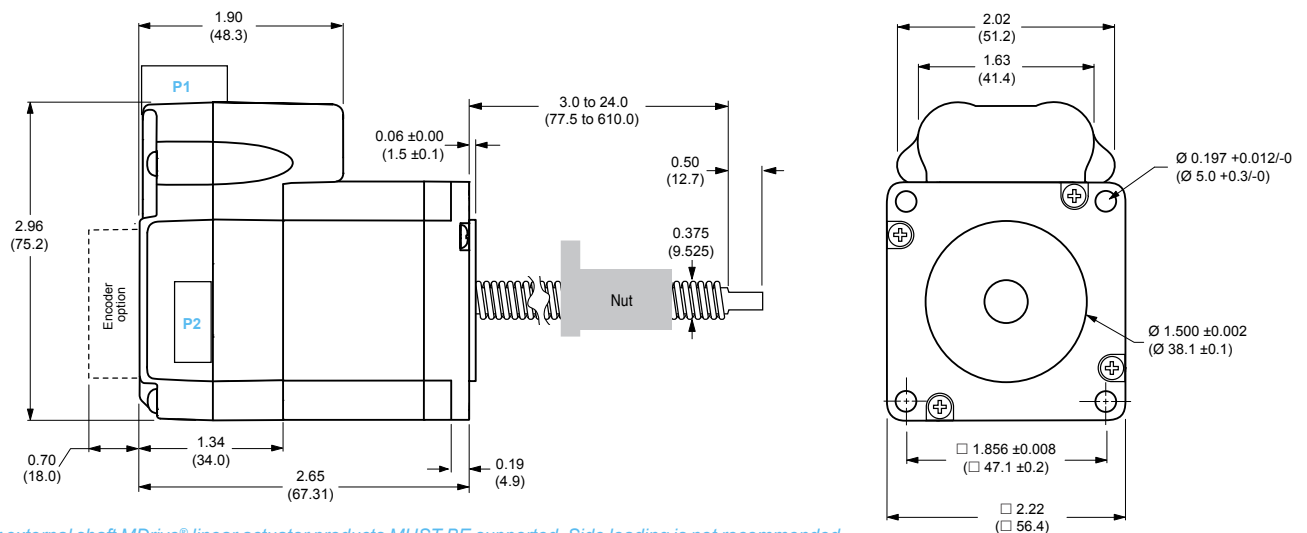

Loads for external shaft MDrive® linear actuator products **MUST BE** supported. Side loading is not recommended.

P1 connector options

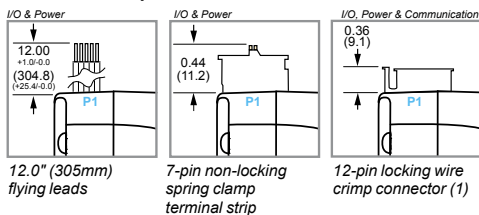

P2 connector options

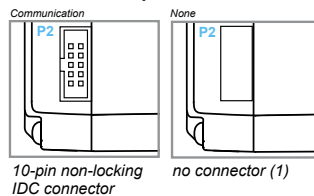

Encoder option

Externally-mounted optical encoder, for External shaft linear actuators

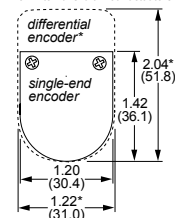

(1) 12-pin locking wire crimp connector at P1 eliminates the P2 connector.

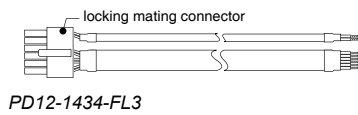
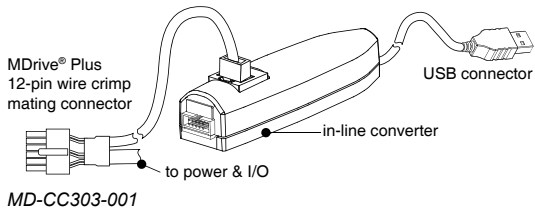
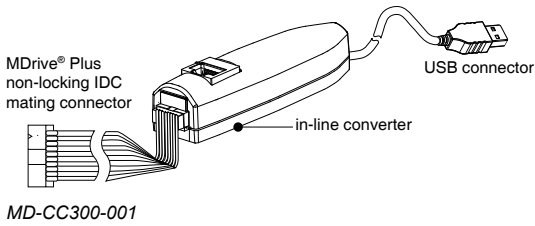

Installation accessories

Description	Length feet (m)	Part number
-------------	-----------------	-------------

QuickStart Kit

For rapid design verification, all-inclusive QuickStart Kits include connectivity, instructions and CD for MDrive Plus Linear Actuator initial functional setup and system testing.

- For MDrive 23 Plus step/direction input products — **add "K" to part number (1)**

Communication converter

Electrically isolated, in-line converter pre-wired with mating connector to conveniently set/program communication parameters for a single MDrive Plus Linear Actuator via a PC's USB port.

- Mates to 10-pin non-locking IDC connector 12.0 (3.6) **MD-CC300-001**
- Mates to 12-pin locking wire crimp connector 12.0 (3.6) **MD-CC303-001**

Prototype development cable

Speed test/development with pre-wired mating connector with other cable end open.

- Mates to 12-pin locking wire crimp connector for I/O, communication and power 10.0 (3.0) **PD12-1434-FL3**

Encoder cables

Pre-wired mating connector with other cable end open.

- For external single-end optical encoder 1.0 (0.3) **ED-CABLE-2**
- For external differential optical encoder with locking connector 6.0 (1.8) **ED-CABLE-6**

Mating connector kit

Connectors for assembly of cables, cable material not supplied. Sold in lots of 5. Manufacturer's crimp tool recommended for crimp connectors.

- 10-pin non-locking IDC connector for communication — **CK-01**
- 12-pin locking wire crimp connector for I/O, communication and power — **CK-03**

Drive protection module

Limits surge current and voltage to a safe level when DC input power is switched on-and-off to an MDrive.

- For all MDrive Linear Actuator products — **DPM75**

(1) See page 8.

MDrive® 23 Plus Linear Actuator

Step / direction input

MDrive® 23 Plus

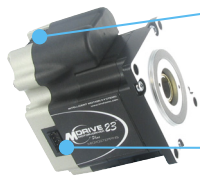

- P1: I/O & Power**
 F = 12" flying leads
 P = non-locking spring clamp terminal strip
 C = 12-pin locking wire crimp (includes I/O, Power & Comm)
- P2: Communication**
 D = SPI with 10-pin IDC non-locking connector
 Z = None. Used with 12-pin locking wire crimp in position P1, which includes communication.

Part numbers														
Example:	K	M	L	M	1	F	S	D	2	3	A	7	-E1	-●
QuickStart Kit	K	M	L	M	1	F	S	D	2	3	A	7	-E1	-●
K = kit option, or leave blank if not wanted														
MDrive Plus Linear Actuator version	K	M	L	M	1	F	S	D	2	3	A	7	-E1	-●
MLM = Step / direction input														
Input type	K	M	L	M	1	F	S	D	2	3	A	7	-E1	-●
1 = Universal input 5 = Differential CW/CCW input														
P1 connector	K	M	L	M	1	F	S	D	2	3	A	7	-E1	-●
F = flying leads P = pluggable C = wire crimp (1)														
Communication	K	M	L	M	1	F	S	D	2	3	A	7	-E1	-●
S = SPI														
P2 connector	K	M	L	M	1	F	S	D	2	3	A	7	-E1	-●
D = IDC Z = none (1)														
Motor size	K	M	L	M	1	F	S	D	2	3	A	7	-E1	-●
23 = NEMA 23 (2.3" / 57 mm)														
Motor length	K	M	L	M	1	F	S	D	2	3	A	7	-E1	-●
A = single stack														
Drive voltage	K	M	L	M	1	F	S	D	2	3	A	7	-E1	-●
7 = +12 to +75 VDC														
Optional encoder (2)													-E1	-●
Leave blank if not wanted														
-E__ = externally-mounted optical encoder with index mark														
line count	100	200	250	256	400	500	512	1000	1024					
single-end part #	E1	E2	E3	EP	E4	E5	EQ	E6	ER					
differential part #	EAL	EBL	ECL	EWL	EDL	EHL	EXL	EJL	EYL					
Linear actuator specifications														-●
Complete the part number from the table below														



Non-captive shaft style



External shaft style

Continued – Part numbers														
Example - linear actuator specifications:	-L	G	1	M	0	6	0	Z	T					
Linear actuator	-L	G	1	M	0	6	0	Z	T					
-L														
Screw lead / pitch	-L	G	1	M	0	6	0	Z	T					
G = 0.375" / 9.525 mm travel per rev A = 0.200" / 5.08 mm travel per rev B = 0.167" / 4.233 mm travel per rev D = 0.083" / 2.116 mm travel per rev														
Shaft style	-L	G	1	M	0	6	0	Z	T					
1 = Non-captive 3 = External														
Screw end finish	-L	G	1	M	0	6	0	Z	T					
M = metric threaded U = UNC threaded S = smooth Z = none														
Screw length	-L	G	1	M	0	6	0	Z	T					
030 = 3.0" (77.5 mm) minimum up to 240 = 24.0" (610.0 mm) maximum, in 0.1" (2.5 mm) increments														
Nut	-L	G	1	M	0	6	0	Z	T					
Z = none, only with Non-captive shaft products G = general purpose, only with External shaft products (3) A = anti-backlash, only with External shaft products (4)														
Coating	-L	G	1	M	0	6	0	Z	T					
T = Teflon Z = None														

(1) Wire crimp connector at P1 includes communication, so the P2 designator is Z=none.
 (2) Only available with External shaft linear actuators.
 (3) Dynamic load limit to 60lbs / 22 kg.
 (4) Dynamic load limit to 25lbs / 11 kg.

Easy MDrive part numbers via an interactive tool at:
www.imshome.com/MDriveLinear.html

Motor specifications			
Stack length			Single
Holding torque		oz-in	90.0
		N-cm	64.0
Rotor inertia		oz-in-sec ²	0.0025
		kg-cm ²	0.18
Maximum screw misalignment		°	± 1
Weight without screw		oz	22.0
		g	625.0
Maximum thrust (1)	Non-captive shaft	lbs	200
		kg	91
	External shaft with general purpose nut	lbs	60
		kg	27
	External shaft with anti-backlash nut	lbs	25
		kg	11
Maximum repeatability	General purpose	inch	0.005
		mm	0.127
	Anti-backlash (2)	inch	0.0005
		mm	0.0127

(1) Performance data for maximum force/load is based on a static load and will vary with a dynamic load.
 (2) Only applicable for External shaft linear actuator with anti-backlash nut.

Speed force characteristics

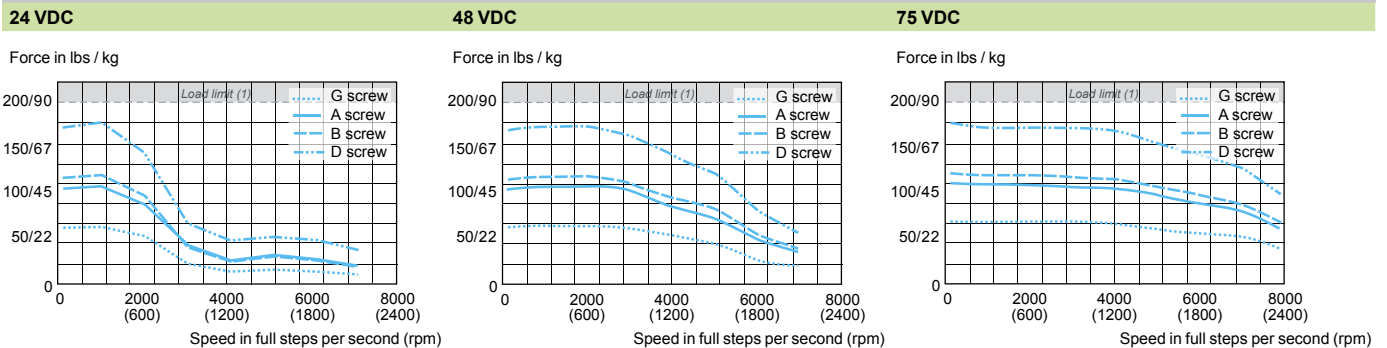

(1) Load limits are for non-captive shaft linear actuators: 200lbs/91kg.
 Load limits for external shaft linear actuators are determined by the nut selected.
 Note: Performance data for maximum force/load is based on a static load and will vary with a dynamic load.

USA SALES OFFICES

Eastern Region

Tel. 862 208-9742 - Fax 973 661-1275

e-mail: e.region@imshome.com

Northeast Region

Tel. 860 368-9703

e-mail: n.region@imshome.com

Central Region

Tel. 860 295-6102

e-mail: c.region@imshome.com

Western Region

Tel. 602 578-7201

e-mail: w.region@imshome.com

State of California

Tel. 310 717-7969

e-mail: california@imshome.com

IMS EUROPEAN SALES MANAGEMENT

4 Quai Des Etroits

69005 Lyon, France

Tel. +33/4 7256 5113 - Fax +33/4 7838 1537

e-mail: europe.sales@imshome.com

TECHNICAL SUPPORT

Tel. +00 (1) 860 295-6102 - Fax +00 (1) 860 295-6107

e-mail: etech@imshome.com

Schneider Electric Motion USA

370 North Main Street, P.O. Box 457

Marlborough, CT 06447 - U.S.A.

Tel. +00 (1) 860 295-6102 - Fax +00 (1) 860 295-6107

e-mail: info@imshome.com

www.schneider-electric-motion.us

© Schneider Electric Motion USA All Rights Reserved.

REV042011

Product Disclaimer and most recent product information online.

IMS
INTELLIGENT MOTION
SYSTEMS, INC.

Schneider
Electric