

DPM75

Drive Protection Module



Mechanical Specifications

Dimensions in Inches (mm)

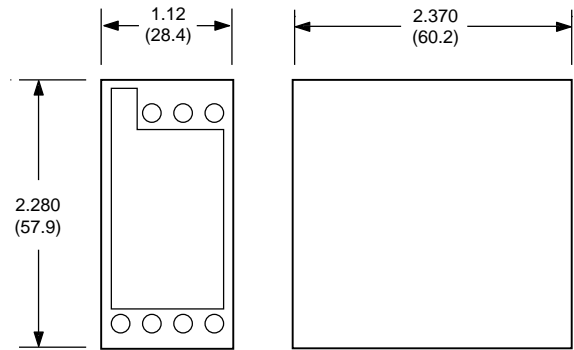

DPM75 Product Overview

The function of the DPM75 Drive Protection Module is to limit the surge current and voltage to a safe level when DC input power is switched on and off to a motor drive. This provides the added protection necessary for reliable motor drive operation when switching the DC power, instead of the recommended AC power to the DC power supply. The device is designed to protect the motor drive when operating under all load conditions. This device does not protect the motor drive from wiring the power incorrectly.

The unit is capable of being used with 48, 60, and 75 volt rated motor drives. An external jumper selection is available so the user can match the circuit to their particular application. The DPM75 is capable of a steady state operating current of 4 amps.

The DPM75 can be used for any frame size motor drive, when properly configured. It can also be used for more than one unit provided the current and voltage do not exceed the DPM75's ratings. The maximum DPM75 ratings are 75 volts and 4 amps.

EXAMPLE — If you are using the DPM75 with one or more MDrive, MForce or MicroLYNX motor drives, acceptable combinations include:

- 1) One 34 frame MDrive up to 75 volts.
- 2) One MForce PowerDrive unit up to 75 volts.
- 3) Two 23 frame MDrives up to 75 volts (excluding AccuStep and quad stack motors).
- 4) Two 23 frame MDrives up to 60 volts.
- 5) Three 17 frame MDrives up to 48 volts (excluding AccuStep).
- 6) Two MForce MicroDrive units up to 48 volts.
- 7) Two 17 frame and one 23 frame MDrives up to 48 volts.
- 8) One MicroLYNX-4 at up to 48 volts.
- 9) One MicroLYNX-7 at up to 75 volts.

Notes and Warnings

Installation, configuration and maintenance must be carried out by qualified technicians only. You must have detailed information to be able to carry out this work. When installing, reference the user manual of the product being used in conjunction with the DPM75.

- Unexpected dangers may be encountered when working with this product!
- Incorrect use may destroy this product and connected components!

The user manuals for all applicable products may be obtained from the Internet at: <http://www.imshome.com/downloads/manuals.html>.

Specifications

Thermal	Min	Typ	Max	Unit
Operating Temperature	0	—	+50	°C

Configuration

The Drive Protection Module may be configured to one of three levels of protection by installing jumpers between the appropriate terminals. They are:

- 48 VDC
- 60 VDC
- 75 VDC

The Drive Protection Module may be used with more than one device, provided the maximum ratings are not exceeded.

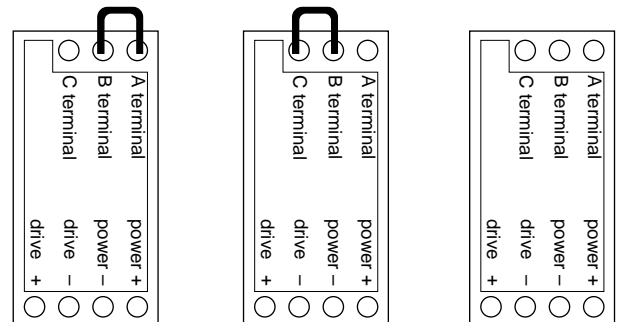

48 VDC drives
Jumper A terminal and B terminal

60 VDC drives
Jumper B terminal and C terminal

75 VDC drives
No jumper

Recommended Wiring

Use the wire gauge recommended for the drive power as recommended by the user manual.

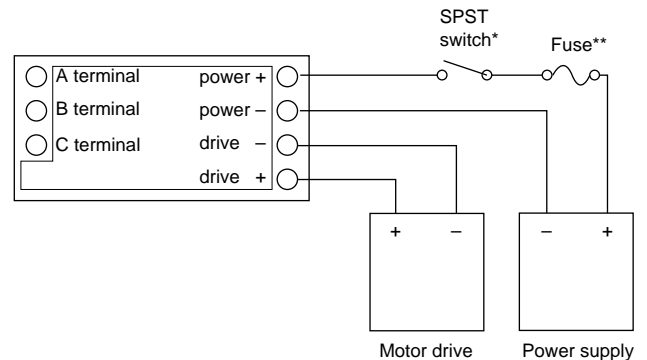

* Do not switch negative side of supply

**Fuse = 6.3 Amp slow blow (recommended: Bussman S505-6.3A or Littelfuse 215006.3). The fuse is optional.

Mounting

The DPM75 is designed to be mounted to a DIN rail.