

# M DRIVE 17™

MOTOR+DRIVER

## MICROSTEPPING



### FEATURES

- Integrated Microstepping Driver and NEMA 17 High Torque 1.8° Stepping Motor
- +12 to +48 VDC Input Voltage
- Low Cost
- Extremely Compact
- Optically Isolated Logic Inputs will Accept +5 to +24 VDC Signals, Sourcing or Sinking†
- Automatic Current Reduction
- Configurable:
  - Motor Run/Hold Current
  - Motor Direction vs. Direction Input
  - Microstep Resolution to 256 Microsteps/Full Step
- Available Configurations:
  - Single Shaft\*
  - Long Life Linear Actuator
  - Optical Encoder\*
  - Control Knob for Manual Positioning\*
  - Integrated Planetary Gearbox\*
- Three Stack Sizes Available\*
- Current and Resolution May Be Switched On-The-Fly
- Single Supply
- Interface Options:
  - Keyed and Locking Pin and Receptacle (C Connector)
  - Pluggable Terminal Strip
  - 12.0" (30.5cm) Flying Leads
- Graphical User Interface (GUI) for Quick and Easy Parameter Setup

\* Rotary Motor Only

† C Connector Version Only. Other Versions Require 5 Volt Sinking Outputs.

### DESCRIPTION

The MDrive NEMA 17 high torque Integrated Motor and Driver is ideal for designers who want the simplicity of a motor with on-board electronics, but without the expense of an indexer on each axis. The low cost MDrive17 allows the system designer to decide the best method of control. The MDrive17's integrated electronics eliminate the need to run the motor cabling through the machine, reducing the potential for problems due to electrical noise.

The MDrive17 uses a NEMA 17 frame size 1.8° high torque stepping motor combined with a microstepping driver, and accepts up to 14 resolution settings from ½ to 256 microsteps per full step. Setup parameters include Microstep Resolution, Motor Run/Hold Current, and Motor Direction with respect to the direction input. These settings may be changed on-the-fly or downloaded and stored in nonvolatile memory with the use of a simple GUI which is provided. This eliminates the need for external switches or resistors. Parameters are changed via an SPI port. MDrive17 operating voltage ranges from +12 to +48 VDC.

The versatile, compact MDrive17 is available in multiple configurations to fit various system needs. These include a single shaft rotary motor, a dual shaft rotary motor available with optical encoder or control knob, a planetary gearbox, or a long life Acme screw linear actuator. The rotary MDrive17 is available in single, double and triple stack sizes: 13, 15 & 19. Interface connections are accomplished using either a 12 position keyed and

locking pin and receptacle (C Connector), a 7 position terminal strip, or 12.0" (30.5cm) flying leads.

The MDrive17 is a compact, powerful and inexpensive solution that will reduce system cost, design and assembly time for a large range of stepping motor applications.

### CONFIGURING

The IMS Motor Interface software is an easy to install and use GUI for configuring the MDrive17 from a computer parallel/SPI port. GUI access is via the IMS SPI Interface included on the CD shipped with the product, or download at [www.imshome.com](http://www.imshome.com). Optional cables are available for ease of connecting and configuring the MDrive.

The IMS Motor Interface features:

- Easy installation.
- Automatic detection of MDrive version and communication configuration.
- Will not set out-of-range values.
- Tool-tips display valid range setting for each option.
- Single screen interface (*below*).

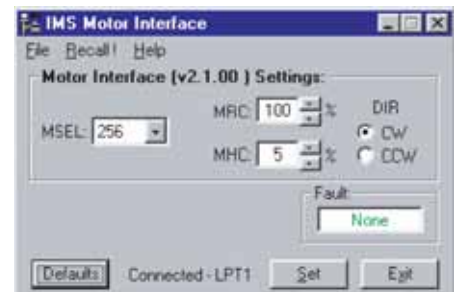

The IMS Motor Interface GUI simplifies MDrive configuring with a single screen interface. (DIR feature with C Connector version only.)

# M DRIVE17 MICROSTEPPING SPECIFICATIONS

## GENERAL SPECIFICATIONS

|   |  |
|---|--|
| Input Voltage (+V) Range*   | +12 to +48 VDC   |
| Isolated Inputs   | Step Clock, Direction & Enable   |
| Isolated Input Voltage Range (Sourcing or Sinking - C Connector Version Only) | +5 to +24 VDC  |
| Step Frequency (Max)  | 2 MHz  |
| Steps per Revolution  | 400, 800, 1000, 1600, 2000, 3200, 5000, 6400, 10000, 12800, 25000, 25600, 50000, 51200 |
| Heat Sink Temperature (Max)   | 85° C  |
| Motor Temperature (Max)   | 100° C   |

\*Power supply current requirements = 2A (maximum) per MDrive17. Actual power supply current will depend on voltage and load.

## PARAMETERS

| SETUP PARAMETERS |   |  |                 |         |
|------------------|---|--|-----------------|---------|
| NAME             | FUNCTION  | RANGE  | UNITS           | DEFAULT |
| MHC              | Motor Hold Current  | 0 to 100   | percent         | 5       |
| MRC              | Motor Run Current   | 1 to 100   | percent         | 25      |
| MSEL             | Microstep Resolution  | 2, 4, 5, 8, 10, 16, 25, 32, 50, 64, 125, 128, 250, 256 | µsteps per step | 256     |
| DIR              | Motor Direction Override<br><i>C Connector Version ONLY</i> | 0/1  | --              | CW      |

All parameters are set using the supplied IMS Motor Interface GUI and may be changed on-the-fly. An optional Parameter Setup Cable is recommended with first orders.

## PIN/WIRE ASSIGNMENTS

### C Connector

| CONNECTOR P1 |                           |
|--------------|---------------------------|
| PIN          | FUNCTION                  |
| 1            | POWER GROUND              |
| 2            | +V (+12 TO +48 VDC)       |
| 3            | OPTOCOUPLER REFERENCE     |
| 4            | STEP CLOCK INPUT          |
| 5            | ENABLE INPUT              |
| 6            | CW / CCW DIRECTION INPUT  |
| 7            | +5 VDC OUTPUT             |
| 8            | SPI CLOCK                 |
| 9            | COMMUNICATIONS GROUND     |
| 10           | SPI MASTER IN - SLAVE OUT |
| 11           | SPI CHIP SELECT           |
| 12           | SPI MASTER OUT - SLAVE IN |

### Pluggable Terminal Strip or Flying Leads

| CONNECTOR P1 |              |                           |
|--------------|--------------|---------------------------|
| PIN          | FLYING LEADS | FUNCTION                  |
| 1            | White        | +5 VDC OPTOCOUPLER SUPPLY |
| 2            | --           | NO CONNECT                |
| 3            | Orange       | STEP CLOCK INPUT          |
| 4            | Blue         | CW / CCW DIRECTION INPUT  |
| 5            | Brown        | ENABLE INPUT              |
| 6            | Black        | POWER GROUND              |
| 7            | Red          | +V (+12 TO +48 VDC)       |

| CONNECTOR P2 (SPI) - 10 Pin Pin-Header |                       |
|--|-----------------------|
| PIN                                    | FUNCTION              |
| 1                                      | NO CONNECT            |
| 2                                      | NO CONNECT            |
| 3                                      | NO CONNECT            |
| 4                                      | CHIP SELECT           |
| 5                                      | GROUND                |
| 6                                      | +5 VDC OUTPUT         |
| 7                                      | MASTER OUT - SLAVE IN |
| 8                                      | CLOCK                 |
| 9                                      | NO CONNECT            |
| 10                                     | MASTER IN - SLAVE OUT |

## ENCODER PIN ASSIGNMENTS

| ENCODER - Single-End |              |
|----------------------|--------------|
| PIN                  | FUNCTION     |
| 1                    | GROUND       |
| 2                    | INDEX        |
| 3                    | CHANNEL A    |
| 4                    | +5 VDC INPUT |
| 5                    | CHANNEL B    |

| ENCODER - Differential |              |     |             |
|------------------------|--------------|-----|-------------|
| PIN                    | FUNCTION     | PIN | FUNCTION    |
| 1                      | NO CONNECT   | 6   | CHANNEL A + |
| 2                      | +5 VDC INPUT | 7   | CHANNEL B - |
| 3                      | GROUND       | 8   | CHANNEL B + |
| 4                      | NO CONNECT   | 9   | INDEX -     |
| 5                      | CHANNEL A -  | 10  | INDEX +     |

Optional Encoder Cables available.

NOTE: For recommended mating connector information, refer to the product's Quick Reference at [www.imshome.com/quick.html](http://www.imshome.com/quick.html)

# MDRIVE17 MOTOR SPECIFICATIONS

## MD1713 Single Stack

Holding Torque .....32 oz-in / 22.6 N-cm  
 Detent Torque .....1.66 oz-in / 1.17 N-cm  
 Rotor Inertia .... 0.00053 oz-in-sec<sup>2</sup> / 0.038 kg-cm<sup>2</sup>  
 Weight (Motor+Driver)..... 9.8 oz / 277.8 g

## MD1715 Double Stack

Holding Torque .....60.0 oz-in / 42.4 N-cm  
 Detent Torque .....2.08 oz-in / 1.47 N-cm  
 Rotor Inertia .... 0.00080 oz-in-sec<sup>2</sup> / 0.057 kg-cm<sup>2</sup>  
 Weight (Motor+Driver)..... 10.5 oz / 297.7 g

## MD1719 Triple Stack

Holding Torque .....74.9 oz-in / 52.9 N-cm  
 Detent Torque .....3.47 oz-in / 2.45 N-cm  
 Rotor Inertia .... 0.00116 oz-in-sec<sup>2</sup> / 0.082 kg-cm<sup>2</sup>  
 Weight (Motor+Driver)..... 15.1 oz / 428.1 g

## MD1713 Linear Actuator

Maximum Thrust ..... 50 lbs / 222 N  
 Maximum Screw Deflection ..... ± 1°  
 Backlash ..... 0.005 in / 0.127 mm  
 Weight (without screw)..... 10.4 oz / 294.8 g

## TORQUE-SPEED CURVES

### Rotary Motor

#### MD1713 Single Stack

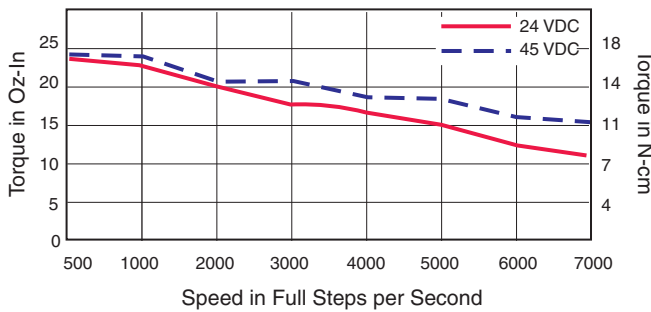

#### MD1715 Double Stack

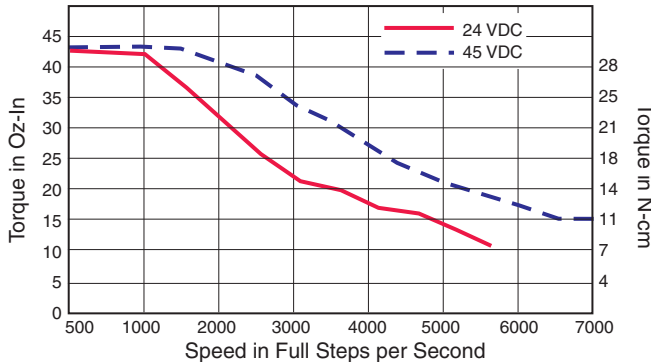

#### MD1719 Triple Stack

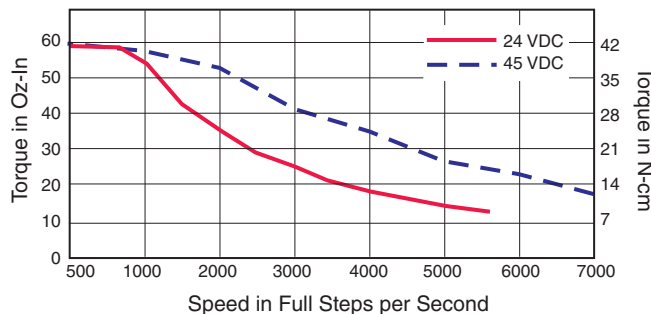

## FORCE-SPEED CURVES

### Linear Actuator

#### 24 VDC

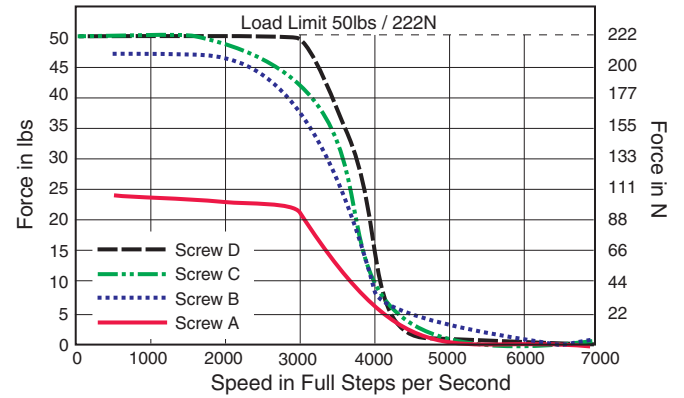

#### 45 VDC

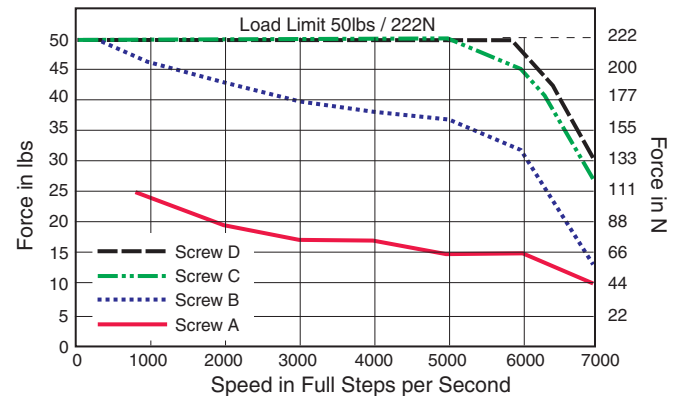

## MDRIVE17 WITH PLANETARY GEARBOX

The MDrive17 is available with a Planetary Gearbox option developed to increase torque at lower speeds, enable better inertia matching and produce finer positional resolutions. These efficient, low maintenance Planetary Gearbox come fully assembled with the MDrive and are offered in a large number of

reduction ratios in 1-, 2- and 3-stage configurations. An optional NEMA Flange allows mounting the Planetary Gearbox to the load using a standard NEMA bolt circle. Planetary Gearbox may be combined with other MDrive17 options, however are unavailable on Linear Actuator versions.

| Parameters                         | 1-Stage | 2-Stage  | 3-Stage   |
|------------------------------------|---------|----------|-----------|
| Permitted Output Torque (oz-in/Nm) | 425/3.0 | 1062/7.5 | 2124/15.0 |
| Gearbox Efficiency                 | 0.80    | 0.75     | 0.70      |
| Maximum Backlash (degree)          | 0.80°   | 0.85°    | 0.90°     |

### Output Side with Ball Bearing

|                                       |          |          |          |
|---------------------------------------|----------|----------|----------|
| Maximum Load, Radial (lb-force/N)     | 36/160   | 52/230   | 67.5/300 |
| Maximum Load, Axial (lb-force/N)      | 11/50    | 18/80    | 25/110   |
| Weight - Gearbox Only (oz/g)          | 14.3/406 | 17.9/508 | 21.5/609 |
| Weight - Gearbox & NEMA Flange (oz/g) | 14.8/420 | 18.5/525 | 22.2/630 |

## PLANETARY GEARBOX MECHANICAL SPECIFICATIONS

Dimensions in Inches (mm)

### Planetary Gearbox for MDrive17

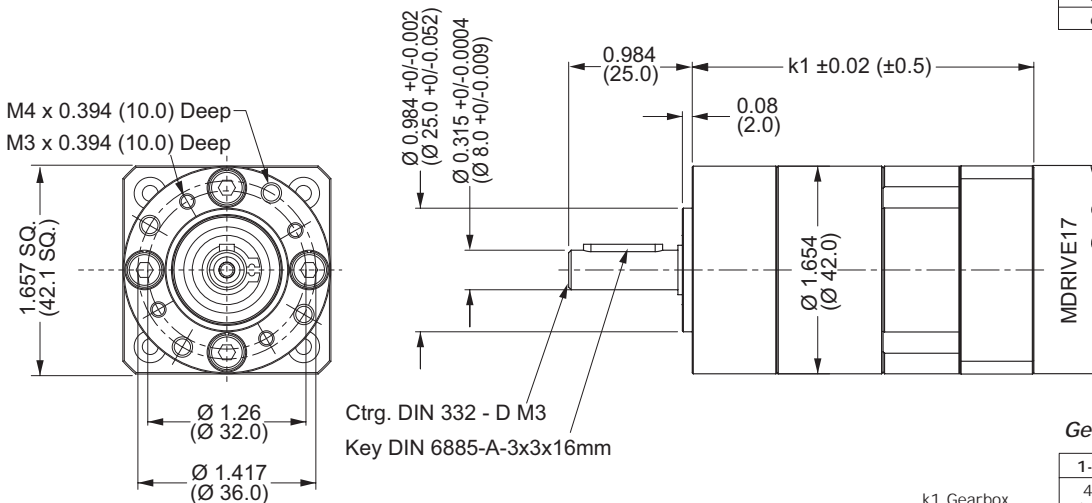

### Gearbox Ratios (Rounded)

| 1-Stage  | 2-Stage  | 3-Stage |
|----------|----------|---------|
| 3.70:1   | 13.73:1  | 50.89:1 |
| 5.18:1   | 15.88:1  | 58.85:1 |
| 6.75:1   | 18.36:1  | 68.06:1 |
| 19.20:1  | 71.16:1  |         |
| 22.20:1  | 78.71:1  |         |
| 25.01:1  | 92.70:1  |         |
| 26.85:1  | 95.17:1  |         |
| 28.93:1  | 99.50:1  |         |
| 34.97:1  | 107.20:1 |         |
| 45.56:1  | 115.07:1 |         |
| 123.97:1 |          |         |
| 129.62:1 |          |         |
| 139.13:1 |          |         |
| 149.90:1 |          |         |
| 168.84:1 |          |         |
| 181.24:1 |          |         |
| 195.26:1 |          |         |
| 236.09:1 |          |         |
| 307.54:1 |          |         |

### Gearbox Lengths Inches (mm)

|                              | 1-Stage          | 2-Stage          | 3-Stage          |
|------------------------------|------------------|------------------|------------------|
| k1 Gearbox                   | 4.315<br>(109.6) | 5.169<br>(131.3) | 6.024<br>(153.0) |
| k2 Gearbox w/<br>NEMA Flange | 4.433<br>(112.6) | 5.287<br>(134.3) | 6.142<br>(156.0) |

### Planetary Gearbox with Optional NEMA Output Flange

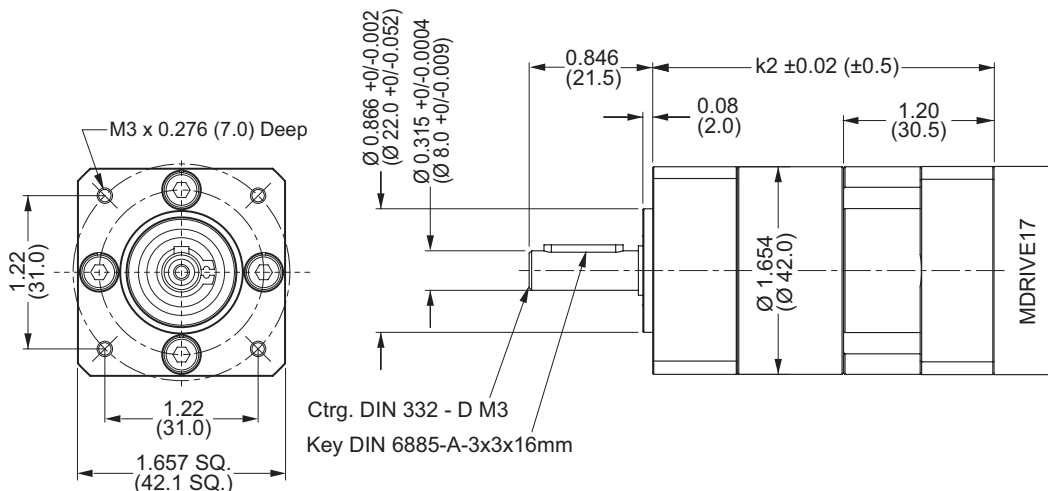

# MDRIVE17 MICROSTEPPING – MECHANICAL SPECIFICATIONS

Dimensions in Inches (mm)

## Rotary MDrive17: Single Shaft, Control Knob & Encoder Versions

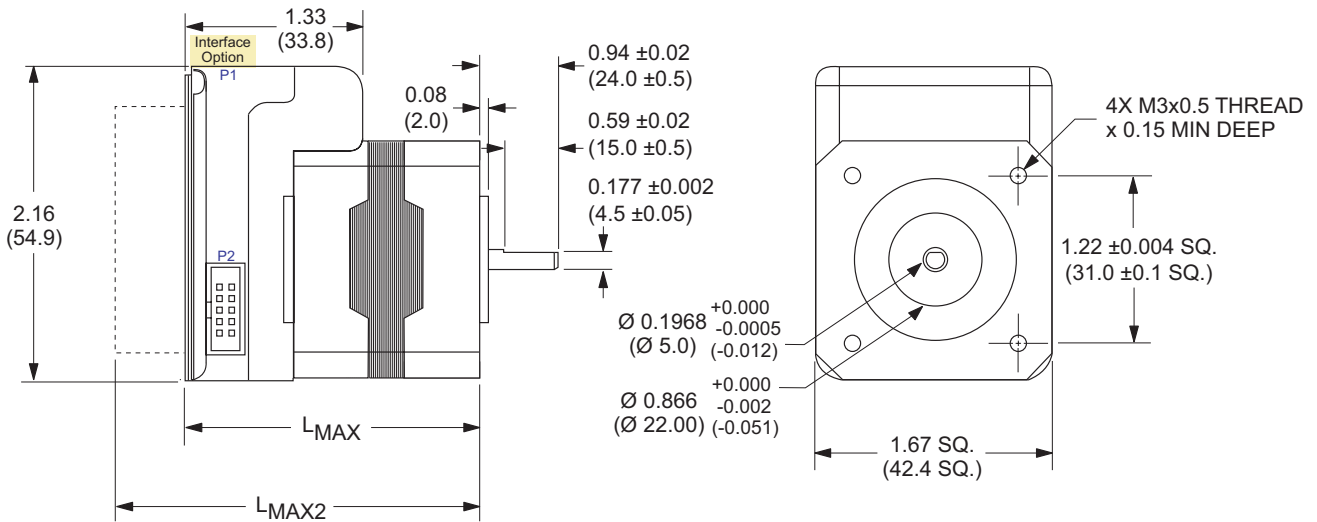

### MDrive Lengths Inches (mm)

| Stack Size | LMAX                 | LMAX2                           |
|------------|----------------------|---------------------------------|
|            | SINGLE SHAFT VERSION | CONTROL KNOB or ENCODER VERSION |
| 1713       | 2.20 (55.9)          | 2.92 (74.2)                     |
| 1715       | 2.43 (61.7)          | 3.15 (80.0)                     |
| 1719       | 2.75 (69.8)          | 3.47 (88.1)                     |

### Interface Options

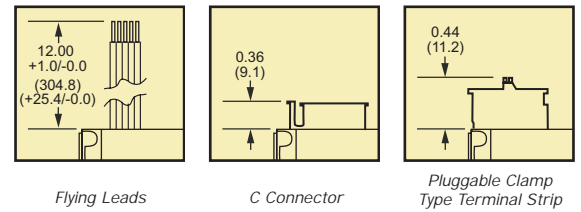

### LMAX2 Options

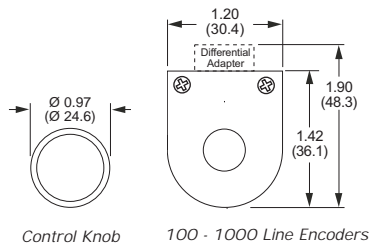

## Linear Actuator MDrive17

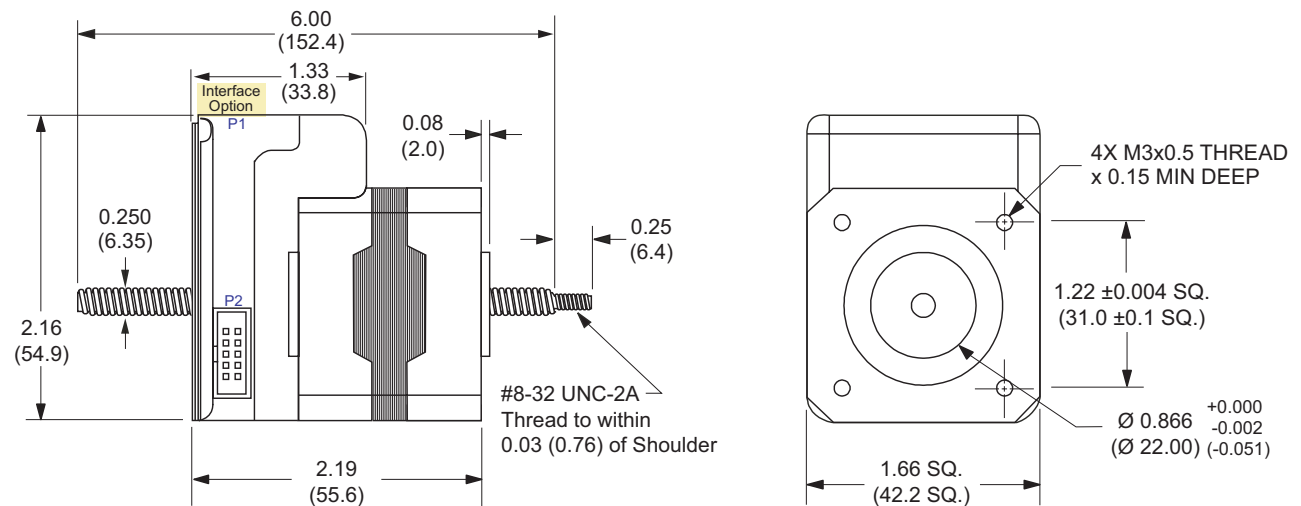

## MDRIVE17 MICROSTEPPING – OPTIONS

### Control Knob

The MDrive17 is available with a factory-mounted rear control knob for manual shaft positioning.

### Planetary Gearbox

Efficient, low maintenance Planetary Gearbox are offered assembled with the MDrive17. Details inside.

### Encoder

The MDrive17 is available with a factory-mounted optical encoder. Available line counts are 100, 200, 250, 400, 500 or 1000. All encoders, except the 1000 line, have an index mark. Encoders are available in both single-end and differential configurations. Order optional Encoder Cables separately:

Single-end Cable (12"/30.5cm) ..... ES-CABLE-2  
Differential Cable (36"/91.5cm) ..... ED-CABLE-2

### Linear Actuator

The MDrive17 with long life Acme Screw Linear Actuator is available with the following travel/full step:

Screw A ..... 0.00125"/full step  
Screw B ..... 0.000625"/full step  
Screw C ..... 0.0003125"/full step

Screw D ..... 0.00015625"/full step  
Standard screw length is 6.0" (152.4mm) plus the mounting end thread. Custom lengths from 2.0" to 24.0" are available without mounting end thread. Linear Actuators are Non-Captive style. Contact the factory regarding Captive Shaft or External styles.

### Parameter Setup Cable and Adapter

The optional 6' (1.8m) Parameter Setup Cable Part No. MD-CC100-000 eliminates the need to wire communications and is recommended with first order. It connects an MDrive's 10 pin pin-header (P2) to a standard DB-25 PC Parallel/SPI port and includes built-in logic level shifting circuitry to accommodate the 3.3v ports on some PCs. In addition, MDrives with C Connector require an Adapter Part No. MD-ADP-1723C to mate the Cable to the 12 position pin and receptacle connector (P1).

### Prototype Development Cable

For testing and development of MDrives with C Connector, the 12" (30.5cm) Prototype Development Cable plugs into the MD-ADP-1723C Adapter and has flying leads for connection to the user interface. Part No. ADP-3512-FL.

## ORDER INFORMATION

| MDRIVE17 MICROSTEPPING   |  |
|--|--|
| <p>Stack Sizes<br/>13' = Single Stack &amp; Linear Actuator<br/>15 = Double Stack<br/>19 = Triple Stack</p> <p>Interface Options<br/>C = Pin &amp; Receptacle<br/>F = 12" Flying Leads<br/>P = Pluggable Clamp Type Terminal Strip</p> | <div style="border: 1px dashed black; padding: 5px; display: inline-block;">OPTION</div> |
| <p><b>Example #1:</b> Part Number <b>MDMC1719</b> is an MDrive17 Microstepping with <b>C</b> Connector, NEMA <b>17</b> motor, stack size <b>19</b>.</p>  |  |

| OPTIONS           |  |   |
|-------------------|--|---|
| Control Knob      | <b>N</b>   | <b>Example #2: MDMC1719N</b><br>Adds a Control Knob to the part shown in example #1.  |
| Planetary Gearbox | <b>G</b><br>Gearbox Ratio<br>Rounded to Nearest Whole Number   | <b>Example #3: MDMC1719G5</b><br>Rounding ratio to the nearest whole number, the above adds a Planetary Gearbox with 5.18:1 ratio to the part shown in example #1. Add -F if optional NEMA Flange is desired.   |
| Encoder           | <b>E</b><br>S = Single End    Line Counts: 100, 200, 250, 400, 500, 1000<br>D = Differential   | <b>Example #4: MDMC1719ED500</b><br>Adds a 500 line count Differential Encoder to the part shown in example #1.   |
| Linear Actuator†  | <b>L</b><br>Screw Type (Travel/Full Step)<br>A = 0.00125"<br>B = 0.000625"<br>C = 0.0003125"<br>D = 0.00015625"<br>Custom Screw Length<br>Range 2.0" to 24.0"<br>Format XX.X<br>eg. 08.5 for an 8.5" Screw<br>(6.0" Screw Length Standard) | <b>Example #5: MDMC1713LC10.5</b><br>Microstepping MDrive17 Linear Actuator with a 0.0003125"/Full Step Acme Screw custom cut to 10.5".<br>MAY NOT be combined with other options.<br><i>Note: MDrive17 Linear Actuator Available ONLY in Stack Size 13</i> |

† Linear Actuator Available **ONLY** in Stack Size 13. (MDMX1713LX)



P.O. Box 457, 370 N. Main Street  
Marlborough, CT 06447 U.S.A.

Phone: 860/295-6102  
Fax: 860/295-6107  
E-mail: info@imshome.com  
Home Page: www.imshome.com

Distributed By:

### TECHNICAL SUPPORT

**Eastern U.S.**  
Phone: 860/295-6102  
Fax: 860/295-6107  
E-mail: etech@imshome.com  
**Western U.S.**  
Phone: 760/966-3162  
Fax: 760/966-3165  
E-mail: wtech@imshome.com

### IMS MOTORS DIVISION

105 Copperwood Way, Suite H  
Oceanside, CA 92054  
Phone: 760/966-3162  
Fax: 760/966-3165  
E-mail: motors@imshome.com

### IMS EUROPE GmbH

Hahnstrasse 10, VS-Schwenningen  
Germany D-78054  
Phone: +49/7720/94138-0  
Fax: +49/7720/94138-2  
E-mail: info@imseuropehome.com  
**European Sales Management**  
4 Quai Des Etoits  
69005 Lyon, France  
Phone: +33/4 7256 5113  
Fax: +33/4 7838 1537  
E-mail: bmartinez@imshome.com  
**German Sales/Technical Support**  
Phone: +49/35205/4587-8  
Fax: +49/35205/4587-9  
E-mail: hruehland@imshome.com

Product information covered by IMS Product Disclaimer available at www.imshome.com. Visit the IMS web site for the most up-to-date product information.

© 2002, 2004 Intelligent Motion Systems, Inc. All Rights Reserved.

REV121604