

# M DRIVE 23<sup>TM</sup>

MOTOR+DRIVER

## SPEED CONTROL



### FEATURES

- Integrated Variable Speed Controller, Microstepping Driver and NEMA 23 High Torque 1.8° Stepping Motor
- Input Voltage:
  - +12 to +48 VDC (MDrive23-4)
  - +24 to +75 VDC (MDrive23-7)
- Digital Oscillator for Accurate Speed Control
- Low Cost
- Extremely Compact
- Available Configurations:
  - Single Shaft\*
  - Long Life Linear Actuator
  - Optical Encoder\*
  - Control Knob for Manual Positioning\*
  - Integrated Planetary Gearbox\*
- Three Stack Sizes Available\*
- Electronically Configurable (Eliminates Potentiometers):
  - Motor Run/Hold Current
  - Acceleration/Deceleration
  - Initial and Max Velocity
  - Speed Control Input Source
  - Microstep Resolution to 256 Microsteps/Full Step
- 2 Modes of Operation Bidirectional or Unidirectional
- 15-25kHz PWM, 0-20mA, 4-20mA or 0 to +5 VDC Speed Control Input with Programmable Center Point
- Single Supply
- Interface Uses Pluggable Terminal Strip or 12.0" (30.5cm) Flying Leads
- Graphical User Interface (GUI) for Quick and Easy Parameter Setup

\* Rotary Motor Only

### DESCRIPTION

The MDrive23 Speed Control offers the system designer low cost, intelligent velocity control integrated with a NEMA 23 high torque stepping motor and a +12 to +48 or +24 to +75 volt microstepping driver.

The MDrive23 Speed Control features a digital oscillator for accurate velocity control with an output frequency of up to 100 kilohertz. Output frequency will vary with the signal applied to the speed control input. Speed can be adjusted by 15-25kHz PWM, 0-20mA, 4-20mA or 0 to +5 volts.

There are two basic modes of operation: bidirectional and unidirectional. By moving the center point, both speed and direction are controlled by the IMS Analog Speed Control GUI. By setting the center point to zero or the lower end of the potentiometer, only velocity is controlled by the speed control input; direction is controlled by a separate digital input.

The MDrive23 Speed Control has 12 setup parameters, configured using the supplied IMS Analog Speed Control GUI. The setup parameters enable the user to configure all MDrive operational parameters which are stored in nonvolatile memory.

The versatile, compact MDrive23 Speed Control is available in multiple configurations to fit various system needs. These options include a single shaft rotary motor, a dual shaft rotary motor available with optical encoder or control knob, a planetary gearbox, or a long life Acme screw linear actuator. The ro-

tary MDrive23 is available in single, double and triple stack sizes: 18, 22 & 31. Interface connections are accomplished using either a 7 position pluggable terminal strip or 12.0" (30.5cm) flying leads.

### CONFIGURING

The IMS Analog Speed Control is a required software GUI for quick and easy parameter setup of the MDrive23 Speed Control from a computer parallel/SPI port. GUI access is via the IMS SPI Interface included on the CD shipped with the product, or download at [www.imshome.com](http://www.imshome.com). An optional Parameter Setup Cable is available for ease of connecting and configuring the MDrive.

IMS Analog Speed Control features:

- Easy installation.
- Automatic detection of MDrive version and communication configuration.
- Will not set out-of-range values.
- Tool-tips display valid range setting for each option.
- Single screen interface (*below*).



Configuring the MDrive Speed Control is simplified with the IMS Analog Speed Control's single screen interface.

# MDRIVE 23 SPEED CONTROL SPECIFICATIONS

## GENERAL SPECIFICATIONS

Speed Control Input .....	15 to 25kHz PWM, 0 to 20mA, 4 to 20mA or 0 to +5 VDC
A/D Resolution .....	10 bit
Speed Control Potentiometer Resistance.....	10 kΩ
Input Voltage (+V) Range* .....	+12 to +48/ +24 to +75 VDC
Stop/Start, Direction (Low Level Input) .....	0 to +1.5 VDC
Stop/Start, Direction (High Level Input) .....	+3.0 to +5.0 VDC
Input Pull-up Resistance (to +5 VDC) Stop/Start, Direction .....	4.99 kΩ
Heat Sink Temperature (Max) .....	85° C
Motor Temperature (Max) .....	100° C

\* Graph illustrates power supply current requirements (maximum) per MDrive23. Actual power supply current will depend on voltage and load.

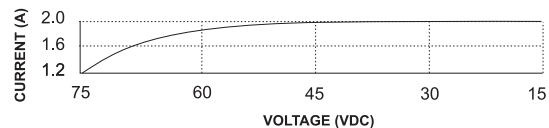

## PARAMETERS

SETUP PARAMETERS				
NAME	FUNCTION	RANGE	UNITS	DEFAULT
ACCL	Accel/Decel	2000 to 65000	steps/sec <sup>2</sup>	2000
C	Joystick Center	0 to 1022	counts	0
DB	Deadband	0 to 255	counts	1
DCLT	Decel Type	Decel at ACCL Rate/No Decel	--	Decel
A1	Input Mode	Volts/4-20mA/0-20mA	--	Volts
FS	Full Scale	1 to 1023	counts	1023
MHC	Motor Hold Current	0 to 100	percent	5
MRC	Motor Run Current	1 to 100	percent	25
MSEL	Microstep Resolution	2, 4, 5, 8, 10, 16, 25, 32, 50, 64, 125, 128, 250, 256	μsteps per step	256
RANGE	VI/VM Range	1 to 8	--	3
VI	Initial Velocity	1 to 100000	steps/sec	400
VM	Maximum Velocity	1 to 100000	steps/sec	20000

All parameters are set using the supplied IMS Analog Speed Control GUI. An optional Parameter Setup Cable is recommended with first orders.

## PIN/WIRE ASSIGNMENTS

CONNECTOR P1 – Pluggable Terminal Strip or Flying Leads		
PIN	FLYING LEADS	FUNCTION
1	Violet	STOP / START INPUT
2	Blue	DIRECTION INPUT
3	Green	SPEED CONTROL INPUT (0-5V (10K POT)/PWM/4-20mA/0-20mA)
4	Yellow	+5 VDC OUTPUT (10K POT)
5	Gray	LOGIC GROUND (10K POT)
6	Black	POWER GROUND
7	Red	+V (+12 TO +48 / +24 TO +75 VDC)

CONNECTOR P2 (SPI) – 10 Pin Pin-Header	
PIN	FUNCTION
4	CHIP SELECT
5	GROUND
6	+5 VDC OUTPUT
7	MASTER OUT - SLAVE IN
8	CLOCK
10	MASTER IN - SLAVE OUT
Omitted numbers are NO CONNECT	

## ENCODER PIN ASSIGNMENTS

ENCODER – Single-End	
PIN	FUNCTION
1	GROUND
2	INDEX
3	CHANNEL A
4	+5 VDC INPUT
5	CHANNEL B

ENCODER – Differential			
PIN	FUNCTION	PIN	FUNCTION
1	NO CONNECT	6	CHANNEL A +
2	+5 VDC INPUT	7	CHANNEL B –
3	GROUND	8	CHANNEL B +
4	NO CONNECT	9	INDEX –
5	CHANNEL A –	10	INDEX +

Optional Encoder Cables available.

NOTE: For recommended mating connector information, refer to the product's Quick Reference at [www.imshome.com/quick.html](http://www.imshome.com/quick.html)

# MDRIVE23 MOTOR SPECIFICATIONS

## MD2218 Single Stack

Holding Torque ..... 90 oz-in / 64 N-cm  
 Detent Torque ..... 3.9 oz-in / 2.7 N-cm  
 Rotor Inertia ..... 0.0025 oz-in-sec<sup>2</sup> / 0.18 kg-cm<sup>2</sup>  
 Weight (Motor+Driver)..... 20.1 oz / 569.8 g

## MD2231 Triple Stack

Holding Torque ..... 239 oz-in / 169 N-cm  
 Detent Torque ..... 9.7 oz-in / 6.86 N-cm  
 Rotor Inertia ..... 0.0065 oz-in-sec<sup>2</sup> / 0.46 kg-cm<sup>2</sup>  
 Weight (Motor+Driver)..... 38.5 oz / 1091.5 g

## MD2222 Double Stack

Holding Torque ..... 144 oz-in / 102 N-cm  
 Detent Torque ..... 5.6 oz-in / 3.92 N-cm  
 Rotor Inertia ..... 0.0037 oz-in-sec<sup>2</sup> / 0.26 kg-cm<sup>2</sup>  
 Weight (Motor+Driver)..... 24.4 oz / 691.7 g

## MD2218 Linear Actuator

Maximum Thrust ..... 200 lbs / 890 N  
 Maximum Screw Deflection ..... ± 1°  
 Backlash ..... 0.005 in / 0.127 mm  
 Weight (without screw)..... 20.4 oz / 578.3 g

### TORQUE-SPEED CURVES

#### Rotary Motor

##### MD2218 Single Stack

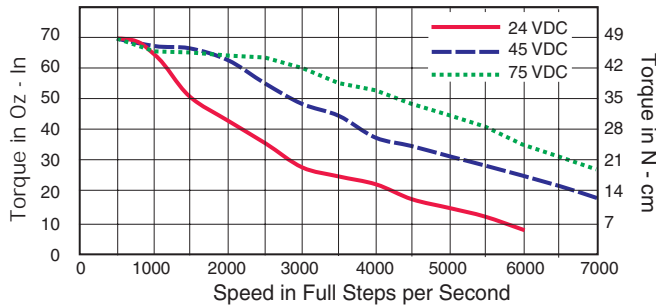

##### MD2222 Double Stack

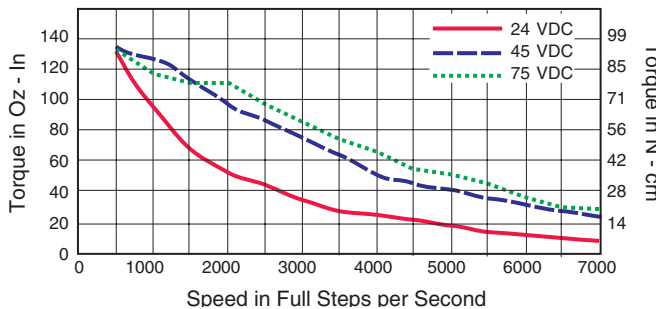

##### MD2231 Triple Stack

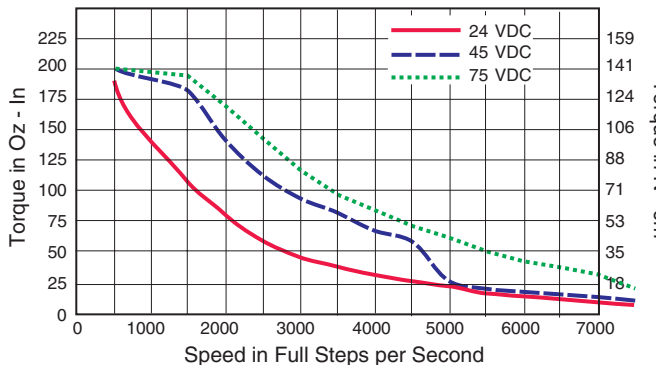

### FORCE-SPEED CURVES

#### Linear Actuator

##### 24 VDC

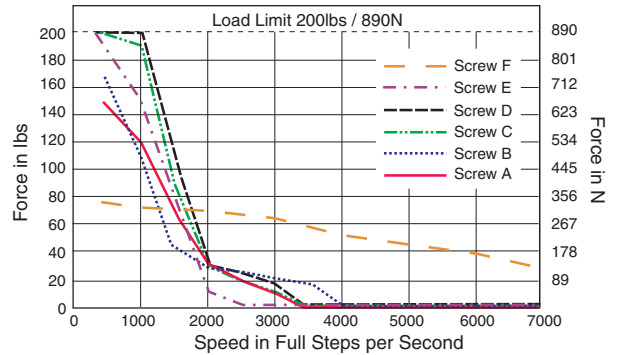

##### 45 VDC

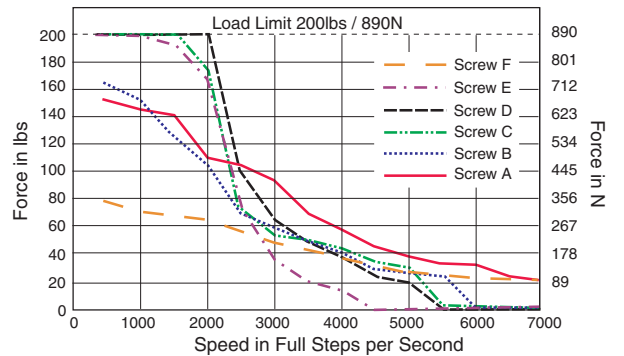

##### 75 VDC

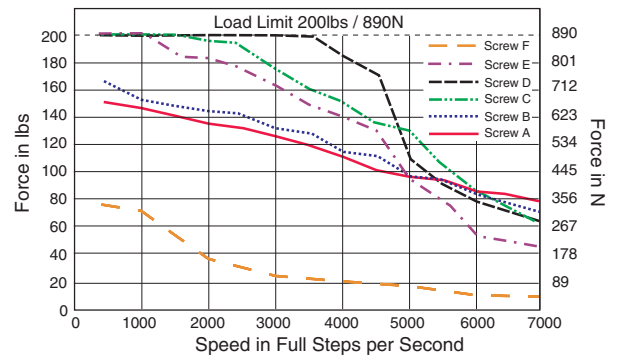

## MDRIVE23 WITH PLANETARY GEARBOX

The MDrive23 is available with a Planetary Gearbox option developed to increase torque at lower speeds, enable better inertia matching and produce finer positional resolutions. These efficient, low maintenance Planetary Gearbox come fully assembled with the MDrive and are offered in a large number of

reduction ratios in 1-, 2- and 3-stage configurations. An optional NEMA Flange allows mounting the Planetary Gearbox to the load using a standard NEMA bolt circle. Planetary Gearbox may be combined with other MDrive23 options, however are unavailable on Linear Actuator versions.

### Parameters

	1-Stage	2-Stage	3-Stage
Permitted Output Torque (oz-in/Nm)	566/4.0	1699/12.0	3540/25.0
Gearbox Efficiency	0.80	0.75	0.70
Maximum Backlash (degree)	0.70°	0.75°	0.80°

### Output Side with Ball Bearing

Maximum Load, Radial (lb-force/N)	45/200	72/320	101/450
Maximum Load, Axial (lb-force/N)	13/60	22/100	34/150
Weight - Gearbox Only (oz/g)	25.0/711	32.2/914	39.4/1117
Weight - Gearbox & NEMA Flange (oz/g)	25.9/735	33.3/945	40.7/1155

## PLANETARY GEARBOX MECHANICAL SPECIFICATIONS

Dimensions in Inches (mm)

### Planetary Gearbox for MDrive23

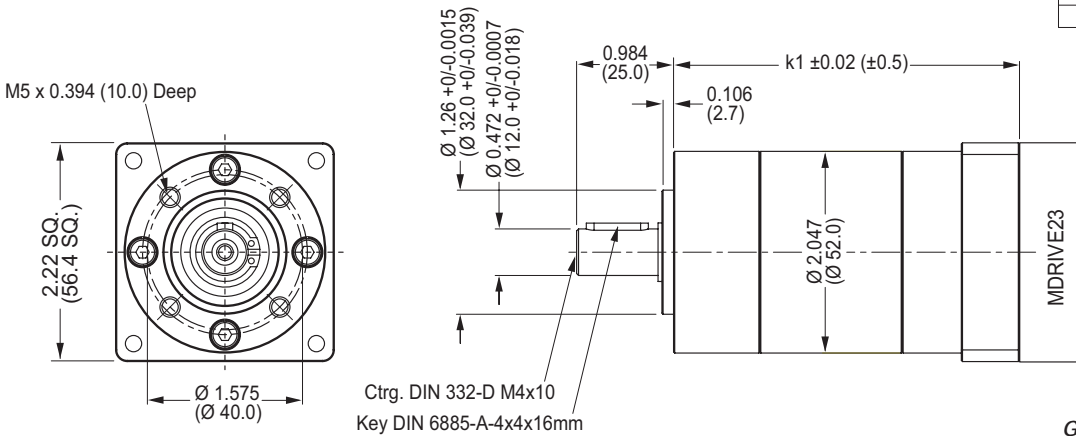

### Gearbox Ratios (Rounded)

1-Stage	2-Stage	3-Stage
3.70:1	13.73:1	50.89:1
5.18:1	15.88:1	58.85:1
6.75:1	18.36:1	68.06:1
19.20:1	71.16:1	
22.20:1	78.71:1	
25.01:1	92.70:1	
26.85:1	95.17:1	
28.93:1	99.50:1	
34.97:1	107.20:1	
45.56:1	115.07:1	
123.97:1		
129.62:1		
139.13:1		
149.90:1		
168.84:1		
181.24:1		
195.26:1		
236.09:1		
307.54:1		

### Gearbox Lengths Inches (mm)

	1-Stage	2-Stage	3-Stage
k1 Gearbox	2.976 (75.6)	3.537 (89.7)	4.087 (103.8)
k2 Gearbox w/ NEMA Flange	3.035 (77.1)	3.59 (91.2)	4.146 (105.3)

### Planetary Gearbox with Optional NEMA Output Flange

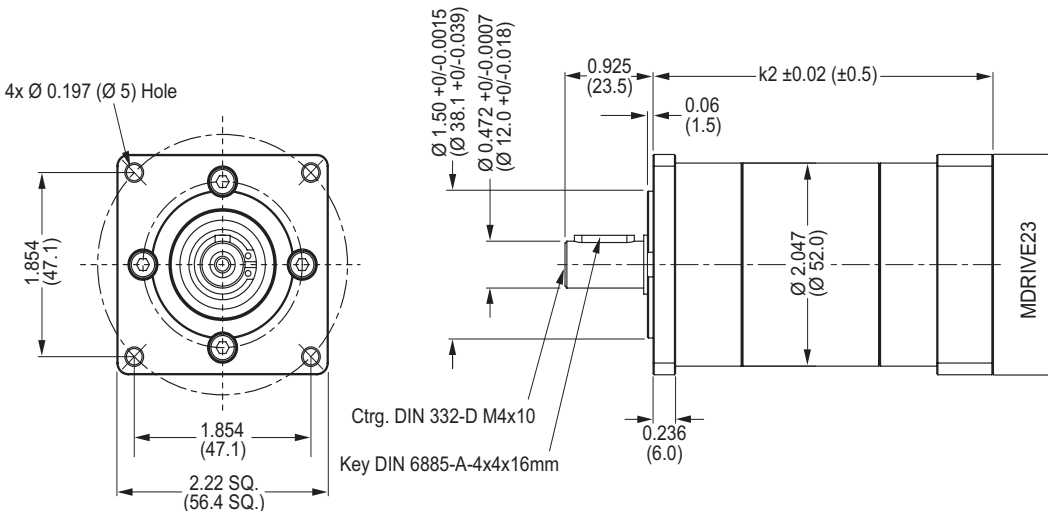

# MDRIVE23 SPEED CONTROL - MECHANICAL SPECIFICATIONS

Dimensions in Inches (mm)

## Rotary MDrive23: Single Shaft, Control Knob & Encoder Versions

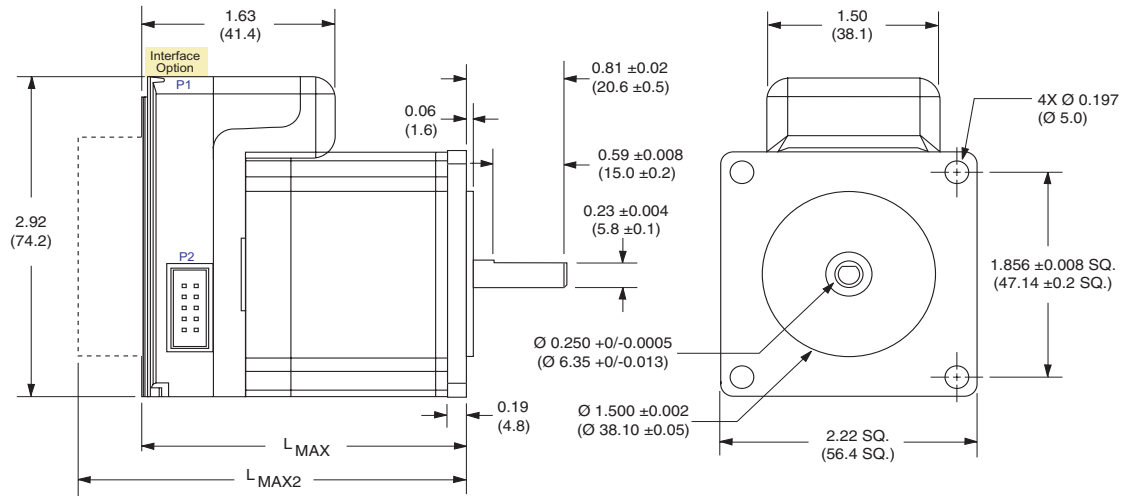

MDrive Lengths Inches (mm)

Stack Size	L <sub>MAX</sub>	L <sub>MAX2</sub>
	SINGLE SHAFT VERSION	CONTROL KNOB or ENCODER VERSION
2218	2.63 (66.8)	3.35 (85.1)
2222	3.00 (76.2)	3.70 (94.0)
2231	3.86 (98.0)	4.57 (116.1)

Interface Options

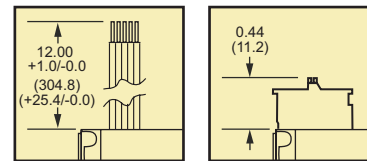

L<sub>MAX2</sub> Options

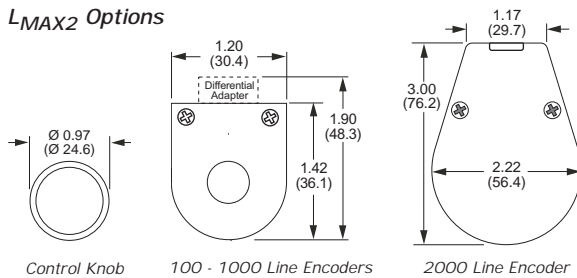

## Linear Actuator MDrive23

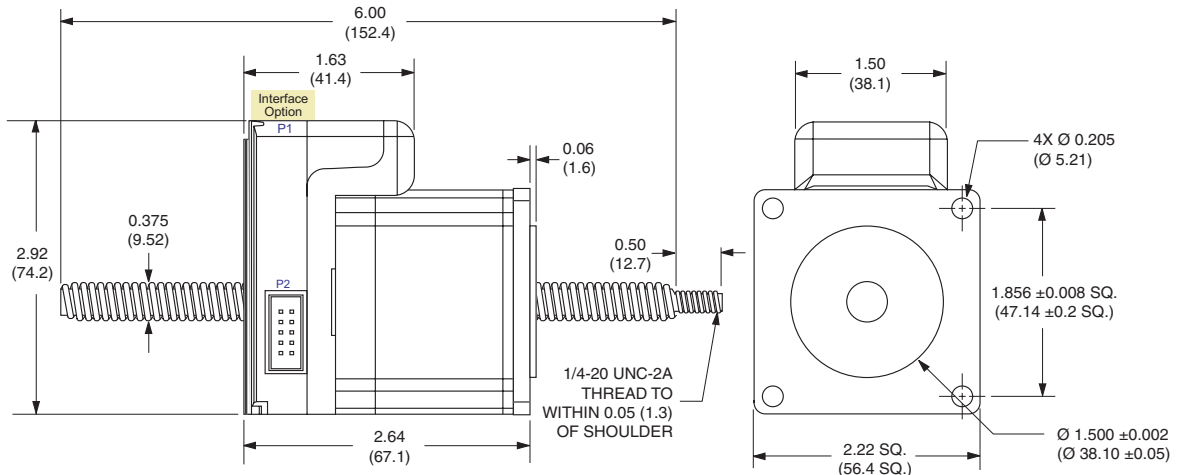

## MDRIVE23 SPEED CONTROL - OPTIONS

### Control Knob

The MDrive23 is available with a factory-mounted rear control knob for manual shaft positioning.

### Planetary Gearbox

Efficient, low maintenance Planetary Gearbox are offered assembled with the MDrive23. Details inside.

### Encoder

The MDrive23 is available with a factory-mounted optical encoder. Available line counts are 100, 200, 250, 400, 500, 1000 or 2000. All encoders, except 1000 line, have an index mark. Encoders are available in both single-end and differential configurations. Order optional Encoder Cables separately:

Single-end Cable (12"/30.5cm) ... ES-CABLE-2\*

Differential Cable (36"/91.5cm)... ED-CABLE-2\*

\*Change "2" to a "6" when ordering 2000 line encoder cable.

### Linear Actuator

The MDrive23 with long life Acme Screw Linear Actuator is available with the following travel/full step:

Screw F ..... 0.002" /full step

Screw A ..... 0.001" /full step

Screw B ..... 0.0008333" /full step

Screw C ..... 0.0005" /full step

Screw D ..... 0.0004167" /full step

Screw E ..... 0.0003125" /full step

Standard screw length is 6.0" (152.4mm) plus the mounting end thread. Custom lengths from 2.0" to 24.0" are available without mounting end thread. Linear Actuators are Non-Captive style. Contact the factory regarding Captive Shaft or External styles.

### Parameter Setup Cable

A low cost accessory which eliminates the need for users to wire communications. This 6' (1.8m) cable includes built-in logic level shifting circuitry to accommodate the 3.3v ports on some PCs and plugs in easily to connect a standard DB-25 PC parallel/SPI port to the MDrive's 10 pin pin-header (P2). Order Cable Part No. MD-CC100-000.

## ORDER INFORMATION

MDRIVE23 SPEED CONTROL	
<p>Stack Sizes 18<sup>†</sup> = Single Stack &amp; Linear Actuator 22 = Double Stack 31 = Triple Stack</p> <p><b>MDO</b> <input type="checkbox"/> <b>22</b> <input type="checkbox"/> - <input type="checkbox"/> <b>OPTION</b></p> <p>Interface Options      Input Voltage F = 12" Flying Leads      4 = 48 VDC P = Pluggable Clamp      7 = 75 VDC Type Terminal Strip</p>	
<p><b>Example #1:</b> Part Number <b>MDOP2222-4</b> is an MDrive23 Speed Control with Pluggable Interface, NEMA 22 motor, stack size 22, and +12 to +48 VDC input voltage range.</p>	

OPTIONS	
Control Knob	<b>N</b> <input type="checkbox"/>
Planetary Gearbox	<b>G</b> <input type="checkbox"/> Gearbox Ratio Rounded to Nearest Whole Number
Encoder	<b>E</b> <input type="checkbox"/> Line Count: 100, 200, 250, 400, 500, 1000, 2000 S = Single End D = Differential
Linear Actuator <sup>†</sup>	<b>L</b> <input type="checkbox"/> Custom Screw Length Range 2.0" to 24.0" Format XX.X eg. 08.5 for an 8.5" Screw (6.0" Screw Length Standard)

<p><b>Example #2: MDOP2222-4N</b> Adds a Control Knob to the part shown in example #1.</p>
<p><b>Example #3: MDOP2222-4G5</b> Rounding ratio to the nearest whole number, the above adds a Planetary Gearbox with 5.18:1 ratio to the part shown in example #1. Add -F if optional NEMA Flange is desired.</p>
<p><b>Example #4: MDOP2222-4ED500</b> Adds a 500 line count Differential Encoder to the part shown in example #1.</p>
<p><b>Example #5: MDOP2218-4LB10.5</b> MDrive23 Speed Control Linear Actuator with a 0.0008333"/Full Step Acme Screw custom cut to 10.5". MAY NOT be combined with other options. <i>Note: MDrive23 Linear Actuator Available ONLY in Stack Size 18</i></p>

<sup>†</sup>Linear Actuator Available ONLY in Stack Size 18. (MDOX2218LX)

**IMS™ INTELLIGENT MOTION SYSTEMS, INC.**  
*Excellence in Motion™*

P.O. Box 457, 370 N. Main Street  
Marlborough, CT 06447 U.S.A.

Phone: 860/295-6102  
Fax: 860/295-6107  
E-mail: info@imshome.com  
Home Page: www.imshome.com

Distributed By:

### TECHNICAL SUPPORT

**Eastern U.S.**  
Phone: 860/295-6102  
Fax: 860/295-6107  
E-mail: etech@imshome.com

**Western U.S.**  
Phone: 760/966-3162  
Fax: 760/966-3165  
E-mail: wtech@imshome.com

### IMS MOTORS DIVISION

105 Copperwood Way, Suite H  
Oceanside, CA 92054  
Phone: 760/966-3162  
Fax: 760/966-3165  
E-mail: motors@imshome.com

### IMS EUROPE GmbH

Hahnstrasse 10, VS-Schwenningen  
Germany D-78054  
Phone: +49/7720/94138-0  
Fax: +49/7720/94138-2  
E-mail: info@imseuropehome.com

### European Sales Management

4 Quai Des Etroits  
69005 Lyon, France  
Phone: +33/4 7256 5113  
Fax: +33/4 7838 1537  
E-mail: bmartinez@imshome.com

### German Sales/Technical Support

Phone: +49/35205/4587-8  
Fax: +49/35205/4587-9  
E-mail: hruhland@imshome.com

Product information covered by IMS Product Disclaimer available at www.imshome.com. Visit the IMS web site for the most up-to-date product information.

© 2002, 2004 Intelligent Motion Systems, Inc. All Rights Reserved.

REV121704