

MDrive 23 Hybrid EtherNet/IP

Product manual
V1.000.10.2011



Important information

This manual is part of the product.

Carefully read this manual and observe all instructions.

Keep this manual for future reference.

Hand this manual and all other pertinent product documentation over to all users of the product.

Carefully read and observe all safety instructions and the chapter "Before you begin - safety information".

Some products are not available in all countries.

For information on the availability of products, please consult the catalog.

Subject to technical modifications without notice.

All details provided are technical data which do not constitute warranted qualities.

Most of the product designations are registered trademarks of their respective owners, even if this is not explicitly indicated.

This page intentionally left blank

Table of Contents

	Important information	3
	Writing conventions and symbols	1
1	Introduction.....	3
	1.1 About this manual.....	3
	1.2 Unit overview.....	3
	1.3 Components and interfaces	4
	1.3.1 Components	4
	1.3.2 Interfaces.....	5
	1.4 Name plate.....	6
	1.5 Part number identification.....	7
	1.6 Documentation and literature references	8
2	Before you begin - safety information.....	9
	2.1 Qualification of personnel.....	9
	2.2 Intended use.....	9
	2.3 Hazard categories	10
	2.4 Basic information.....	11
	2.5 Standards and terminology	13
3	Technical data.....	15
	3.1 Environmental conditions	15
	3.2 Mechanical data	16
	3.2.1 Degree of protection	16
	3.2.2 Mounting position.....	17
	3.2.3 Dimensions	17
	3.3 Electrical data.....	18
	3.3.1 Supply voltage V_{DC} at P3	18
	3.3.2 I/O interface at P1.....	19
	3.3.3 Fieldbus interface at P2.....	21
	3.4 Motor data	22
	3.4.1 Specifications.....	22
	3.4.2 Performance curves.....	22
4	Basics.....	23
	4.1 Functional safety	23
	4.1.1 Working with IEC 61508	23
5	Engineering.....	25
	5.1 External power supply units	25
	5.1.1 Supply voltage	25
	5.2 Ground design.....	27
	5.3 Monitoring functions	28
6	Installation.....	29
	6.1 Electromagnetic compatibility, EMC.....	30
	6.2 Mechanical installation	31
	6.3 Electrical installation.....	34
	6.3.1 Overview of all connectors.....	35
	6.3.2 Connection of the supply voltage V_{DC}	35
	6.3.3 Connection of the I/O interface	39

- 6.3.4 Connection of the fieldbus interface 45
- 6.4 Checking wiring 46
- 7 Commissioning..... 47**
 - 7.1 Preparing for commissioning..... 49
 - 7.1.1 Installing the TCP/IP Configuration Utility..... 49
 - 7.2 Commissioning fieldbus parameters 50
 - 7.2.1 IP Address and subnet mask..... 50
- 8 Operation..... 51**
 - 8.1 Basics..... 51
 - 8.1.1 Overview..... 51
 - 8.2 Supported objects 52
 - 8.2.1 Standard objects..... 52
 - 8.2.2 Manufacturer specific objects 52
- 9 Diagnostics and troubleshooting 53**
 - 9.1 Fieldbus communication error diagnostics 53
 - 9.2 Status LEDs 54
- 10 Accessories and spare parts..... 55**
 - 10.1 Accessories 55
- 11 Service, maintenance and disposal..... 57**
 - 11.1 Service address..... 58
 - 11.2 Maintenance..... 58
 - 11.3 Replacing units..... 58
 - 11.4 Shipping, storage, disposal 59
- 12 Glossary 61**
 - 12.1 Units and conversion tables 61
 - 12.1.1 Length..... 61
 - 12.1.2 Mass 61
 - 12.1.3 Force..... 61
 - 12.1.4 Power..... 62
 - 12.1.5 Rotation 62
 - 12.1.6 Torque 62
 - 12.1.7 Moment of inertia 62
 - 12.1.8 Temperature 62
 - 12.1.9 Conductor cross section 63
 - 12.2 Terms and Abbreviations 63

List of Figures

Figure 1.1: Components and Interfaces	4
Figure 1.3: Part numbering	7
Figure 3.1: Mounting positions	17
Figure 3.1: Dimensions [inches (mm)]	17
Figure 3.5: Overview of connectors	18
Figure 3.6: Speed Torque Curves	22
Figure 6.1: Overview of connectors	35
Figure 6.2: Pin Assignment supply voltage	37
Figure 6.3: Connecting supply voltage VDC wiring	38
Figure 6.4: I/O interface pin assignments	39
Figure 6.5: Connecting I/O interface wiring	40
Figure 6.6: Switched sinking input	41
Figure 6.7: NPN sinking input	41
Figure 6.8: PNP sourcing input	41
Figure 6.9: Sinking output to an inductive load	42
Figure 6.10: Sinking output to an LED	42
Figure 6.11: Sourcing output to inductive lo	42
Figure 6.12: Capture/Trip I/O equivalent circuit	43
Figure 6.13: Analog input	44
Figure 6.14: Fieldbus interface pin assignments	45
Figure 7.1: Configuration tab	50
Figure 8.1: EtherNet/IP network	51
Figure 9.1: Status indicator LEDs	54

Writing conventions and symbols



Work steps If work steps must be performed consecutively, this sequence of steps is represented as follows:

- Special prerequisites for the following work steps
- ▶ Step 1
- ◁ Specific response to this work step
- ▶ Step 2

If a response to a work step is indicated, this allows you to verify that the work step has been performed correctly.

Unless otherwise stated, the individual steps must be performed in the specified sequence.

Bulleted lists The items in bulleted lists are sorted alphanumerically or by priority. Bulleted lists are structured as follows:

- Item 1 of bulleted list
- Item 2 of bulleted list
 - Subitem for 2
 - Subitem for 2
- Item 3 of bulleted list

Making work easier Information on making work easier is highlighted by this symbol:



Sections highlighted this way provide supplementary information on making work easier.

Parameters Parameters are shown as follows

RC Motor Run Current

Units of measure Measurements are given US units, metric values are given in SI units in parenthesis.

Examples”

1.00 in (25.4 mm)
100 oz-in (70 N-cm)

Page intentionally left blank

1 Introduction

1

1.1 About this manual

This manual is valid for MDrive 23 Hybrid standard products with EtherNet/IP industrial protocol. This chapter lists the type code for this product. The type code can be used to identify whether your product is a standard product or a customized model.

1.2 Unit overview

The MDrive® Hybrid EtherNet/IP consists of a stepper motor and integrated electronics. The product integrates interfaces, drive and control electronics and the power stage.

Hybrid Motion Technology™ monitors the location of the rotor relative to the stator in terms of motor steps. If the location equals or exceeds a set limit (or bounds), HMT will intervene to prevent loss of synchronization. This is achieved by “slowing” or “accelerating” the stator to a speed that equals the rotor, such that the rotor and stator lead or lag stays within bounds. This change in stator commutation speed will continue until a change in either commanded motor speed or load requirements allows the motor to create sufficient torque at the commanded speed.

To further enhance performance and efficiency, variable current control can be enabled to allow only the required phase current necessary to perform a move. By using variable current control, motor heating is minimized while system efficiency is increased.

Available protocols are EtherNet/IP industrial protocol, MODBUS/TCP, MCode/TCP and on a single device.

All setup parameters are set via the fieldbus interface.

1.3 Components and interfaces

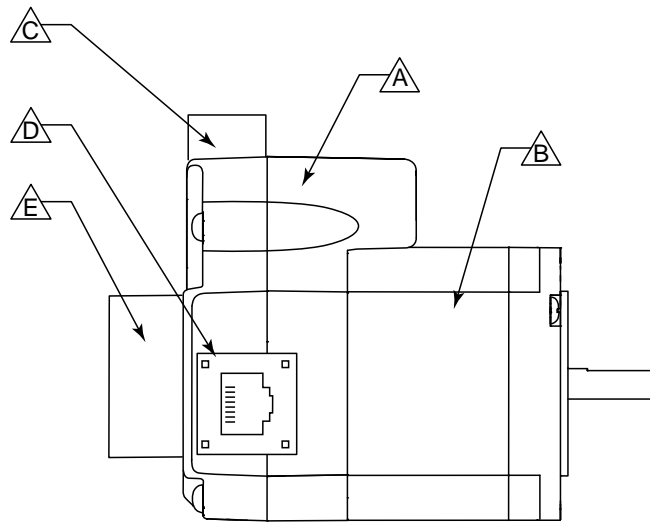

Figure 1.1: Components and Interfaces

- (A) Electronics housing
- (B) Two phase stepper motor
- (C) DC power and I/O interface
- (D) Ethernet
- (E) Control knob option
- (F) Protective earth
- (G) LED indicators

1.3.1 Components

Motor The motor is a two phase brushless stepper motor. The motor has a high torque density due to the use of the latest magnetic materials and enhanced design. The step angle of the motor is 1.8°.

Electronics housing The electronics system is comprised of control electronics and power stage.

The drive system is controlled by streaming commands via the Ethernet interface using the EtherNet/IP standard and manufacturer specific object classes.

1.3.2 Interfaces

Standard available interfaces.

DC power supply voltage

The supply voltage V_{DC} supplies the drive and control electronics and the power stage.



The ground connections of all interfaces are galvanically connected. For more information see chapter 5.2 "Ground design". This chapter also provides information on protection against reverse polarity.

I/O interface

The I/O interface operates at the following signal levels:

- 12 to 24V Aux-Power input to supply power to logic circuits in the event of main supply loss.
- 4 - 24V I/O points configurable as input or output
- 1 TTL level high speed input configurable as capture input or a trip output
- 0 to 10V analog signal

The 24V signals are programmable as general purpose or to pre-defined input or output functions.

The reference voltage or current is applied to the analog input can be used for a number of programmatically defined operations.

Ethernet interface

The Ethernet interface provides a connection to the EtherNet network..

A PC may be connected to the interface via CAT5/6 cabling and RJ45 connectors. The commissioning software may then be used for tasks such as configuring the IP and gateway address and mapping the Assembly object (0x04) .

The Ethernet interface is also used for firmware upgrades.

1.4 Name plate

The product label is located on the underside of the electronics housing and has the following information

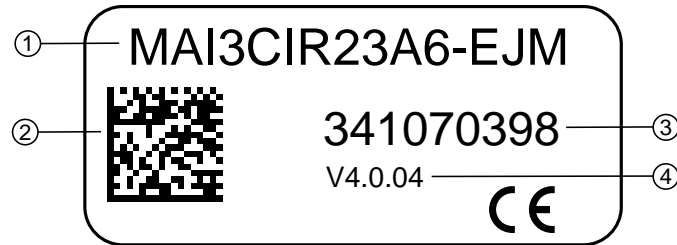

Figure 1.2: Name plate

- (1) Part number
- (2) Datamatrix containing all pertinent information about the device
- (3) Serial number
- (4) Firmware revision

1.5 Part number identification

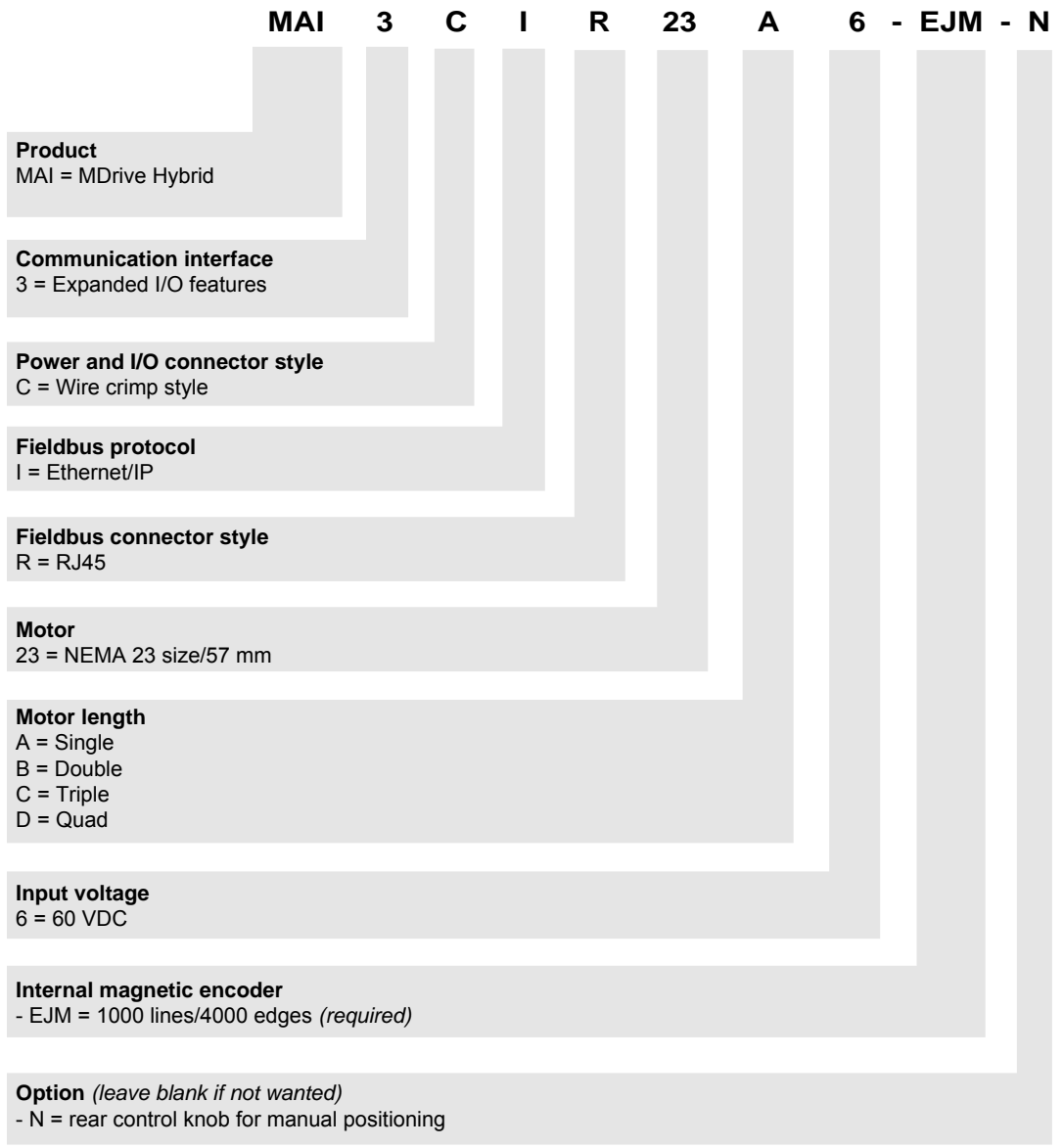

Figure 1.3: Part numbering

1.6 Documentation and literature references

This document should be used in conjunction with the following product manuals.

- EtherNet/IP Fieldbus Manual
- MODBUS/TCP Fieldbus Manual
- MCode Programming and Software Reference Manual

Source product manuals

The current product manuals are available for download from the Internet.

<http://www.schneider-electric-motion.us>

2 Before you begin - safety information

2

The information provided in this manual supplements the product manual. Carefully read the product manual before using the product.

2.1 Qualification of personnel

Only appropriately trained persons who are familiar with and understand the contents of this manual and all other pertinent product documentation are authorized to work on and with this product. In addition, these persons must have received safety training to recognize and avoid hazards involved. These persons must have sufficient technical training, knowledge and experience and be able to foresee and detect potential hazards that may be caused by using the product, by changing the settings and by the mechanical, electrical and electronic equipment of the entire system in which the product is used.

All persons working on and with the product must be fully familiar with all applicable standards, directives, and accident prevention regulations when performing such work.

2.2 Intended use

The functions described in this manual are only intended for use with the basic product; you must read and understand the appropriate product manual.

The product may only be used in compliance with all applicable safety regulations and directives, the specified requirements and the technical data.

Prior to using the product, you must perform a risk assessment in view of the planned application. Based on the results, the appropriate safety measures must be implemented.

Since the product is used as a component in an entire system, you must ensure the safety of persons by means of the design of this entire system (for example, machine design).

Operate the product only with the specified cables and accessories. Use only genuine accessories and spare parts.

Any use other than the use explicitly permitted is prohibited and can result in hazards.

Electrical equipment should be installed, operated, serviced, and maintained only by qualified personnel.

The product must NEVER be operated in explosive atmospheres (hazardous locations, Ex areas).

2.3 Hazard categories

Safety instructions to the user are highlighted by safety alert symbols in the manual. In addition, labels with symbols and/or instructions are attached to the product that alert you to potential hazards.

Depending on the seriousness of the hazard, the safety instructions are divided into 4 hazard categories.

▲ DANGER

DANGER indicates an imminently hazardous situation, which, if not avoided, will result in death or serious injury.

▲ WARNING

WARNING indicates a potentially hazardous situation, which, if not avoided, **can result** in death, serious injury, or equipment damage.

▲ CAUTION

CAUTION indicates a potentially hazardous situation, which, if not avoided, **can result** in injury or equipment damage.

CAUTION

CAUTION used without the safety alert symbol, is used to address practices not related to personal injury (e.g. **can result** in equipment damage).

2.4 Basic information

▲ DANGER

UNINTENDED CONSEQUENCES OF EQUIPMENT OPERATION

When the system is started, the drives are usually out of the operator's view and cannot be visually monitored.

- Only start the system if there are no persons in the hazardous area.

Failure to follow these instructions will result in death or serious injury.

▲ WARNING

UNEXPECTED MOVEMENT

Drives may perform unexpected movements because of incorrect wiring, incorrect settings, incorrect data or other errors.

Interference (EMC) may cause unpredictable responses in the system.

- Carefully install the wiring in accordance with the EMC requirements.
- Ensure the BRIDGE ENABLE input is inactive to avoid an unexpected restart of the motor before switching on and configuring the drive system.
- Do NOT operate the drive system with unknown settings or data.
- Perform a comprehensive commissioning test.

Failure to follow these instructions can result in death or serious injury.

▲ WARNING**LOSS OF CONTROL**

- The designer of any control scheme must consider the potential failure modes of control paths and, for certain critical functions, provide a means to achieve a safe state during and after a path failure. Examples of critical control functions are emergency stop, overtravel stop, power outage and restart.
- Separate or redundant control paths must be provided for critical functions.
- System control paths may include communication links. Consideration must be given to the implication of unanticipated transmission delays or failures of the link.
- Observe all accident prevention regulations and local safety guidelines. 1)
- Each implementation of the product must be individually and thoroughly tested for proper operation before being placed into service.

Failure to follow these instructions can result in death or serious injury.

1) For USA: Additional information, refer to NEMA ICS 1.1 (latest edition), "Safety Guidelines for the Application, Installation, and Maintenance of Solid State Control" and to NEMA ICS 7.1 (latest edition), "Safety Standards for Construction and Guide for Selection, Installation and Operation of Adjustable-Speed Drive Systems".

▲ CAUTION**UNEXPECTED BEHAVIOR AND DESTRUCTION OF SYSTEM COMPONENTS**

When you work on the wiring and when you unplug or plug in connectors, this may cause unexpected behavior and destruction of system components.

- Switch the power supply off before working on the wiring.

Failure to follow these instructions can result in injury or equipment damage.

2.5 Standards and terminology

Technical terms, terminology and the corresponding descriptions in this manual are intended to use the terms or definitions of the pertinent standards.

In the area of drive systems, this includes, but is not limited to, terms such as “safety function”, “safe state”, “fault”, “fault reset”, “failure”, “error”, “error message”, “warning”, “warning message”, etc.

Among others, these standards include:

- IEC 61800 series: “Adjustable speed electrical power drive systems”
- IEC 61800-7 series: “Adjustable speed electrical power drive systems - Part 7-1: Generic interface and use of profiles for power drive systems - Interface definition”
- IEC 61158 series: “Industrial communication networks - Field-bus specifications”
- IEC 61784 series: “Industrial communication networks - Profiles”
- IEC 61508 series: “Functional safety of electrical/electronic/programmable electronic safety-related systems”

3 Technical data

3

This chapter contains information on the ambient conditions and on the mechanical and electrical properties of the device family and the accessories.

3.1 Environmental conditions

Ambient operating conditions The maximum permissible ambient temperature during operation depends on the distance between the devices and the required power. Observe the pertinent instructions in the chapter Installation.

The following relative humidity is permissible during operation.

Operating temperature	[°C]	-20 ... 50 (no icing)
Temperature variation	[°C/min]	0.5
Humidity	[%]	5 ... 95 (non-condensing)

Ambient conditions: transportation and storage The environment during transport and storage must be dry and free from dust. The maximum vibration and shock load must be within the specified limits.

Temperature	[°C]	-25 ... 70
Temperature variation	[°C]	-25 ... 30
Humidity	[%]	5 ... 95 (non-condensing)

Maximum operating temperatures

Power stage ¹⁾	[°C]	85
Motor ²⁾	[°C]	100

- 1) May be read via parameter
- 2) Measured on the surface

Installation altitude

The installation altitude is defined as height above sea level

Installation altitude ¹⁾	[ft (m)]	3280 (1000)
-------------------------------------	----------	-------------

- 3) Installation above 3280 (1000) may require derating output current and maximum ambient temperature.

Vibration and shock

Vibration, sinusoidal
Shock, non-sinusoidal

EMC

Emission	EIC61800-3 (Category C2)
Noise immunity	IEC61000-6-2

3.2 Mechanical data

3.2.1 Degree of protection

IP degree of protection

The product has the following IP degree of protection as per EN 60529.

Degree of protection	IP20
----------------------	------

The total degree of protection is determined by the component with the lowest degree of protection.

IP degrees of protection overview

First digit		Second digit	
Protection against intrusion of objects		Protection against intrusion of water	
0	No protection	0	No protection
1	External objects >50 mm	1	Vertically falling dripping water
2	External objects >12 mm	2	Dripping water falling at an angle (75° ... 90°)
3	External objects >2.5 mm	3	Spraying water
4	External objects >1 mm	4	Splashing water
5	Dust-protected	5	Water jets
6	Dust-tight	6	Heavy sea
		7	Immersion
		8	Submersion

3.2.2 Mounting position

The following mounting positions are defined and approved as per EN 60034-7:

- IM B5 drive shaft horizontal
- IM V1 drive shaft vertical, shaft end down
- IM V3 drive shaft vertical, shaft end up

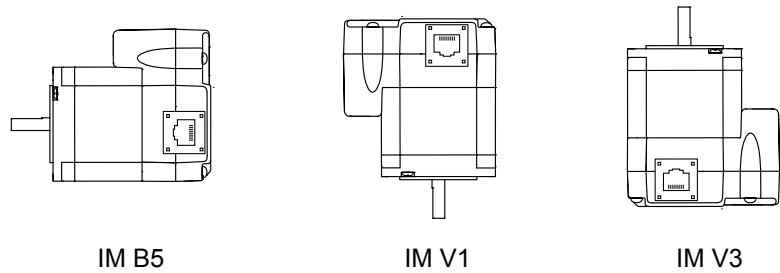
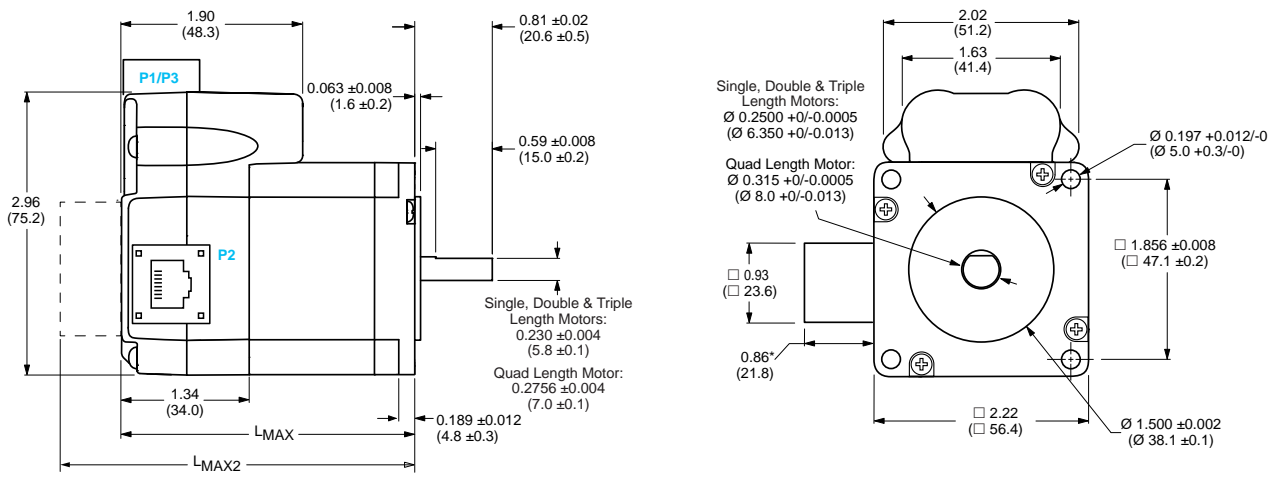

Figure 3.1: Mounting positions

3.2.3 Dimensions



Motor stack length	Lmax (1)	Lmax2 (2)
Single	2.65 (67.31)	3.36 (85.34)
Double	3.02 (76.71)	3.73 (94.74)
Triple	3.88 (98.55)	4.59 (116.59)
Quad	5.28 (134.15)	5.99 (152.19)

1) Single shaft.
2) Control knob.

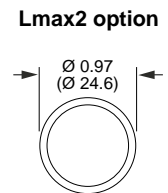

Figure 3.1: Dimensions [inches (mm)]

3.3 Electrical data

Overview of connectors

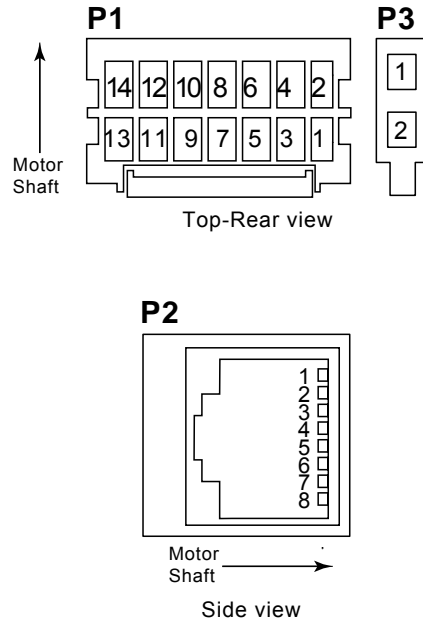

Figure 3.5: Overview of connectors

3.3.1 Supply voltage v_{DC} at P3

CAUTION	
SWITCHING DC/HOT PLUGGING!	
Do not connect or disconnect power, logic, or communication while the device is in a powered state.	
Remove DC power by powering down at the AC side of the DC power supply.	
Failure to follow these instructions may result in damage to system components!	

MDrive 23 Hybrid EtherNet/IP		
Limit values min/max ¹⁾	[+V _{dc}]	12/60
Ripple at nominal voltage	[%]	5
Max. current input	[A]	3.5
Fuse to be connected upstream ²⁾	[A]	

- 1) The actual power requirement is often significantly lower, because the maximum possible motor torque is usually not required for operation of a system.
- 2) See chapter 5.1.1 "Supply voltage"

3.3.2 I/O interface at P1

CAUTION	
ELECTRICAL OVERSTRESS	
The general purpose I/O is tolerant to +24 VDC. The following listed I/O points are TTL level and only tolerant to +5 VDC:	
1) Capture/Trip	
Do not exceed +5 VDC on this point.	
Failure to follow these instructions may result in damage to system components!	

General purpose I/O

The signal I/O functions are programmable in function . They may be used as sinking or sourcing inputs or outputs.

Configured as inputs

Voltage range	[+V _{dc}]	5 ... 24
---------------	---------------------	----------

Configured as outputs

Voltage rating	Sinking	[V _{dc}]	+24
	Sourcing	[V _{dc}]	+12 ... +24
Current rating (one channel)		[mA]	600
Protection	Sinking	Over temp, short circuit	
	Sourcing	Transient over voltage, inductive clamp	

Analog input

Voltage mode 0 - 5	[V _{dc}]	0 ... 5
Voltage mode 0 - 10	[V _{dc}]	0 ... 10
Current loop mode	[mA]	4 ... 20
		0 ... 20
Resolution	[Bits]	10

Capture/trip I/O One high speed I/O point may be configured as either a capture input or a trip output.

Configured as Capture input

Voltage	[V _{dc}]	5
Resolution	[bits]	32
Filter range		50 nS ... 12.9 μS
		10 MHz ... 38.8 kHz

Configured as Trip output

Voltage (with 2kΩ load to ground)	[V _{dc}]	5
Resolution	[bits]	32
Speed	[nS]	150

Auxiliary supply voltage VDC

Aux power is used to maintain power to the logic circuits and retain information stored in counters, registers and user variable in the event of system power loss. It is not a required connection.



NOTE: The Auxiliary power input will not provide power to the communication interface. In the event of main power loss control commands to the device will not be processed.

Limit values min/max	[+V _{dc}]	12/24
Max. current input	[mA]	194

3.3.3 Fieldbus interface at P2

Ethernet

Characteristic		Ethernet RJ45
Baud rate	[Mbps]	10 ... 100
Protocols		EtherNet/IP
	Port 502	MCode/TCP
	Port 503	MODBUS/TCP
Isolation		Galvanic

3.4 Motor data

3.4.1 Specifications

		Single	Double	Triple	Quad
Holding torque	oz-in (N-cm)	90.0 (64)	144 (102)	239 (169)	283 (200)
Detent torque	oz-in (N-cm)	3.9 (2.7)	5.6 (3.92)	9.7 (6.86)	14.2 (10.0)
Rotor inertia	oz-in-sec ² (kg-cm ²)	0.0025 (0.18)	0.0037 (0.26)	0.0065 (0.46)	0.0108 (0.76)
Radial load limit	lbs (kg)	15 (6.8)	15 (6.8)	15 (6.8)	15 (6.8)
Axial load limit	lbs (kg)	0	0	0	0
Weight	oz (gm)	21.6 (612.3)	26.4 (784.4)	39.2 (1111.3)	61.6 (1746.3)

3.4.2 Performance curves

Single stack length

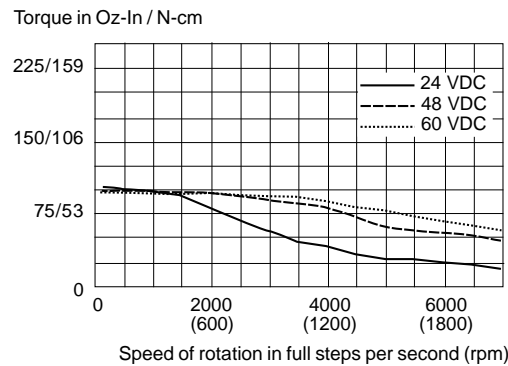

Double stack length

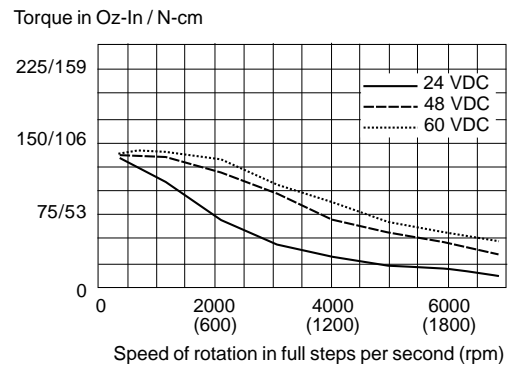

Triple stack length

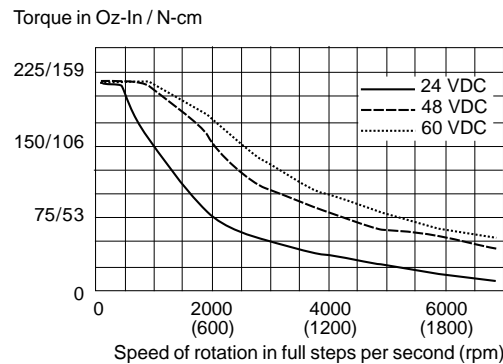

Quad stack length

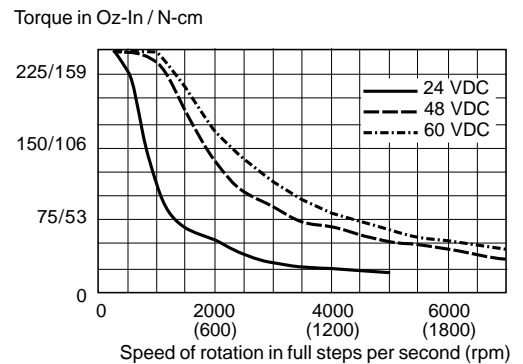

Figure 3.6: Speed Torque Curves

4 Basics

4

4.1 Functional safety

Automation and safety engineering are two areas that were completely separated in the past but recently have become more and more integrated.

Engineering and installation of complex automation solutions are greatly simplified by integrated safety functions.

Usually, the safety engineering requirements depend on the application. The level of the requirements results from the risk and the hazard potential arising from the specific application.

4.1.1 Working with IEC 61508

IEC 61508 standard

The standard IEC 61508 “Functional safety of electrical/electronic/programmable electronic safety-related systems” covers the safety-related function. It is not only one single component but the entire function chain (e.g. from the sensor through the logical processing unit to the actuator) that is considered as one single unit. This function chain must meet the requirements of the specific safety integrity level as a whole. Systems and components that can be used in various applications for safety tasks with comparable risk levels can be developed on this basis.

SIL, Safety Integrity Level

The standard IEC 61508 defines 4 safety integrity levels (SIL) for safety functions. SIL1 is the lowest level and SIL4 is the highest level. A hazard and risk analysis serves as a basis for determining the required safety integrity level. This is used to decide whether the relevant function chain is to be considered as a safety function and which hazard potential it must cover.

PFH, Probability of a dangerous hardware failure per hour

To maintain the safety function, the IEC 61508 standard requires various levels of measures for avoiding and controlling faults, depending on the required SIL. All components of a safety function must be subjected to a probability assessment to evaluate the effectiveness of the measures implemented for controlling faults. This assessment determines the PFH (probability of a dangerous failure per hour) for a safety system. This is the probability per hour that a safety system fails in a hazardous manner and the safety function cannot be correctly executed. Depending on the SIL, the PFH must not exceed certain values for the entire safety system. The individual PFH values of a function chain are added; the total PFH value must not exceed the maximum value specified in the standard.

Page intentionally left blank

5 Engineering

5

This chapter contains information on the application of the product that is vital in the design phase.

5.1 External power supply units

▲ DANGER

ELECTRIC SHOCK CAUSED BY INCORRECT POWER SUPPLY UNIT

The `VDC` and `AUX_PWR` supply voltages are connected with many exposed signal connections in the drive system.

- Use a power supply unit that meets the PELV (Protective Extra Low Voltage) requirements.

Failure to follow these instructions will result in death or serious injury.

5.1.1 Supply voltage

General The power supply unit must be rated for the power requirements of the drive. The input current can be found in the technical data.

The actual power requirements are often significantly lower because the maximum possible motor torque is usually not required for normal operation of a system.

When designing the system, note that the input current of the drive is higher during the motor acceleration phase than during constant movement.

Regeneration condition (back EMF) Note the following for drives with large external mass moments of inertia or for highly dynamic applications:

Motors return regeneration energy during deceleration. The DC bus can store a limited amount of energy in the capacitors. Connecting additional capacitors to the DC bus increases the amount of energy that can be stored.

If the capacity of the capacitors is exceeded, the excess energy must be discharged via internal or external braking resistors.

Overvoltage conditions can be limited by adding a braking resistor with a corresponding braking resistor controller. This converts the regenerated energy to heat energy during deceleration.

▲ CAUTION

LOSS OF CONTROL DUE TO REGENERATION CONDITION

Regeneration conditions resulting from braking or external driving forces may increase the VDC supply voltage to an unexpected level. Components not rated for this voltage may be destroyed or cause malfunctions.

- Verify that all VDC consumers are rated for the voltage occurring during regeneration conditions (for example limit switches).
- Use only power supply units that will not be damaged by regeneration conditions.
- Use a braking resistor controller, if necessary.

Failure to follow these instructions can result in injury or equipment damage.

5.2 Ground design

The ground connections of all interfaces are galvanically connected, including the ground for the VDC supply voltage.

The following points must be considered when you wire the drives in a system:

- The voltage drop in the VDC power supply lines must be kept as low as possible (less than 1 V). At higher ground potential differences between different drives, the communication / control signals may be affected.
- If the distance between the system components is greater, it is recommended to use decentralized power supply units close to the individual drives to supply the VDC voltage. However, the ground connections of the individual power supply units must be connected with the largest possible conductor cross section.
- If the master controller (e.g. PLC, IPC etc.) does not have galvanically isolated outputs for the drives, you must verify that the current of the VDC supply voltage has no path back to the power supply unit via the master controller. Therefore, the master controller ground may be connected to the VDC supply voltage ground at a single point only. This is usually the case in the control cabinet. The ground contacts of the various signal connectors in the drive are therefore not connected; there is already a connection via the VDC supply voltage ground.
- If the controller has a galvanically isolated interface for communication with the drives, the ground of this interface must be connected to the signal ground of the first drive. This ground may be connected to a single drive only to avoid ground loops. This also applies to a galvanically isolated CAN connection.

Equipotential bonding conductors

Potential differences can result in excessive currents on the cable shields. Use equipotential bonding conductors to reduce currents on the cable shields. The equipotential bonding conductor must be rated for the maximum current flowing. Practical experience has shown that the following conductor cross sections can be used:

- AWG 4 (16 mm²) for equipotential bonding conductors up to a length of 650 ft (200 m)
- AWG 4 (20 mm²) for equipotential bonding conductors with a length of more than 650 ft (200 m)

5.3 Monitoring functions

The monitoring functions in the product can help to guard the system and reduce the risks involved in a system malfunction. These monitoring functions may not be used to protect persons.

The following monitoring functions are available and be monitored by two methods:

- 1) **Software:** may be monitored using software via the fieldbus interface
- 2) **Hardware:** may be monitored using the signal outputs via the I/O interface.

6 Installation

6

▲ WARNING

LOSS OF CONTROL

- The designer of any control scheme must consider the potential failure modes of control paths and, for certain critical functions, provide a means to achieve a safe state during and after a path failure. Examples of critical control functions are EMERGENCY STOP, overtravel stop, power outage and restart.
- Separate or redundant control paths must be provided for critical functions.
- System control paths may include communication links. Consideration must be given to the implication of unanticipated transmission delays or failures of the link.
- Observe all accident prevention regulations and local safety guidelines. 1)
- Each implementation of the product must be individually and thoroughly tested for proper operation before being placed into service.

Failure to follow these instructions can result in death or serious injury.

1) For USA: Additional information, refer to NEMA ICS 1.1 (latest edition), "Safety Guidelines for the Application, Installation, and Maintenance of Solid State Control" and to NEMA ICS 7.1 (latest edition), "Safety Standards for Construction and Guide for Selection, Installation and Operation of Adjustable-Speed Drive Systems".

▲ CAUTION

RISK OF INJURY WHEN REMOVING CIRCUIT BOARD PLUGS

- When removing them note that the connectors must be unlocked.
 - Supply voltage VDC: Unlock by pulling at the plug housing
 - Miscellaneous: Unlock by pressing the locking lever
- Always hold the plug to remove it (not the cable).

Failure to follow these instructions can result in injury or equipment damage.



Chapter 5, Engineering, contains basic information that you should now before starting the installation.

6.1 Electromagnetic compatibility, EMC

▲ WARNING
<p>SIGNAL AND DEVICE INTERFERENCE</p> <p>Signal interference can cause unexpected responses of device.</p> <ul style="list-style-type: none"> • Install the wiring in accordance with the EMC requirements. • Verify compliance with the EMC requirements. <p>Failure to follow these instructions can result in death or serious injury.</p>

This drive system meets the EMC requirements according to the standard IEC 61800-3, if the described measures are implemented during installation. If it is operated outside this scope, note the following:

▲ WARNING
<p>HIGH-FREQUENCY INTERFERENCE</p> <ul style="list-style-type: none"> • In a domestic environment this product may cause high-frequency interference that may require action to suppress interference. <p>Failure to follow these instructions can result in death or serious injury.</p>

EMC measures	Effect
Keep cables as short as possible. Do not install unnecessary cable loops, use short cables from the star point in the control cabinet to the external ground connection.	Reduces capacitive and inductive interference.
Ground the product via the motor flange or with a ground strap to the ground connection at the cover of the connector housing.	Reduces emissions, increases immunity.
Ground shields of digital signal wires at both ends by connecting them to a large surface or via conductive connector housings.	Reduces interference affecting the signal wires, reduces emissions
Connect large surface areas of cable shields, use cable clamps and ground straps	Reduces emissions.

The following cables must be shielded:

- Supply voltage VDC
- I/O interface
- Fieldbus interface

Equipotential bonding conductors

Potential differences can result in excessive currents on the cable shields. Use equipotential bonding conductors to reduce currents on the cable shields. The equipotential bonding conductor must be rated for the maximum current flowing. Practical experience has shown that the following conductor cross sections can be used:

- AWG 4 (16 mm²) for equipotential bonding conductors up to a length of 650 ft (200 m)
- AWG 4 (20 mm²) for equipotential bonding conductors with a length of more than 650 ft (200 m)

6.2 Mechanical installation

▲ CAUTION
<p>HOT SURFACES</p> <p>Depending on the operation, the surface may heat up to more than 100°C (212°F).</p> <ul style="list-style-type: none"> ● Do not allow contact with the hot surfaces. ● Do not allow flammable or heat-sensitive parts in the immediate vicinity. ● Consider the measures for heat dissipation described. ● Check the temperature during test runs. <p>Failure to follow these instructions can result in injury or equipment damage.</p>

▲ CAUTION
<p>MOTOR DAMAGE AND LOSS OF CONTROL</p> <p>Shock or strong pressure applied to the motor shaft may destroy the motor.</p> <ul style="list-style-type: none"> ● Protect the motor shaft during handling and transportation. ● Avoid shocks to the motor shaft during mounting. ● Do not press parts onto the shaft. Mount parts to the shaft by glueing, clamping, shrink-fitting or screwing. <p>Failure to follow these instructions can result in injury or equipment damage.</p>

CAUTION
<p>CABLE HARNESSING</p> <p>Ensure that cables are adequately harnessed to provide strain relief.</p> <ul style="list-style-type: none"> ● Minimum cable bend radius is 4 times the cable diameter. ● Cables must be secured to prevent movement of the connector shell. <p>Failure to follow these instructions can result in equipment damage.</p>

▲ WARNING**MOTOR WITHOUT BRAKING EFFECT**

If power outage and faults cause the power stage to be switched off, the motor is no longer stopped by the brake and may increase its speed even more until it reaches a mechanical stop.

- Verify the mechanical situation.
- If necessary, use a cushioned mechanical stop or a suitable brake.

Failure to follow these instructions can result in death or serious injury.

▲ WARNING**LOSS OF BRAKING FORCE DUE TO WEAR OR HIGH TEMPERATURE**

Applying the holding brake while the motor is running will cause excessive wear and loss of the braking force. Heat decreases the braking force.

- Do not use the brake as a service brake.
- Note that “EMERGENCY STOPS” may also cause wear
- At operating temperatures of more than 80°C (176°F), do not exceed a maximum of 50% of the specified holding torque when using the brake.

Failure to follow these instructions can result in death or serious injury.

▲ WARNING**LOAD FALLS DURING SWITCHING ON**

When the brake of stepping motor drives is released and external forces are applied (vertical axes), the load may fall if the friction is low.

- In such applications, limit the load to a maximum of 25% of the static holding torque.

Failure to follow these instructions can result in death or serious injury.



To install a drive in locations difficult to access, it may be useful to carry out the electrical installation first and then install the fully wired drive.

- Heat dissipation* The motor may become very hot, e.g. in the case of incorrect arrangement of multiple motor. The surface temperature of the motor must not exceed 100 °C during continuous operation.
- Verify that the maximum temperature is not exceeded.
 - Verify that there is sufficient heat dissipation, e.g. by means of good ventilation or heat dissipation via the motor flange.
- Mounting* The motor is designed to be mounted using four screws. The motor flange must be mounted on a flat surface to avoid mechanical tension from being transmitted to the housing. Painted surfaces have an insulating effect. During mounting verify that the motor flange is mounted in such a way as to allow for good conductivity (electrical and thermal).
- Mounting screw sizes [standard (metric)]
- MDrive 23: #10 (M5)
- Mounting distances* No minimum clearances are required for installation. However, note that the motor can become very hot. Observe the bending radii of the cables used.
- Ambient conditions* Observe the permissible ambient conditions.

6.3 Electrical installation

▲ CAUTION**DAMAGE TO SYSTEM COMPONENTS AND LOSS OF CONTROL**

Interruptions of the negative connection of the controller supply voltage can cause excessively high voltages at the signal connections.

- Do not interrupt the negative connection between the power supply unit and load with a fuse or switch.
- Verify correct connection before switching on.
- Do not connect the controller supply voltage or change its wiring while the is supply voltage present..

Failure to follow these instructions can result in injury or equipment damage.



Chapter 5, Engineering, contains basic information that you should now before starting the installation.

6.3.1 Overview of all connectors

Overview of connectors

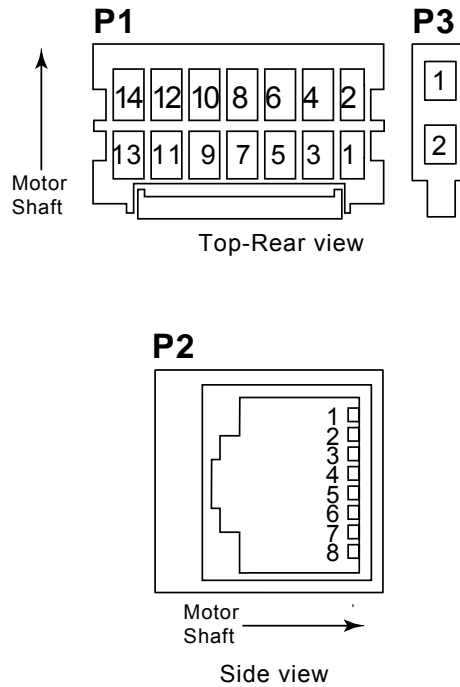

Figure 6.1: Overview of connectors

Connector	Assignment
P3	Supply voltage VDC
P1	I/O interface
P2	Fieldbus interface

6.3.2 Connection of the supply voltage VDC

▲ DANGER

ELECTRIC SHOCK CAUSED BY INCORRECT POWER SUPPLY UNIT

The VDC and AUX_PWR INPUT supply voltages are connected with many exposed signal connections in the drive system.

- Use a power supply unit that meets the PELV (Protective Extra Low Voltage) requirements.

Failure to follow these instructions will result in death or serious injury.

▲ CAUTION**LOSS OF CONTROL DUE TO REGENERATION CONDITION**

Regeneration conditions resulting from braking or external driving forces may increase the VDC supply voltage to an unexpected level. Components not rated for this voltage may be destroyed or cause malfunctions.

- Verify that all VDC consumers are rated for the voltage occurring during regeneration conditions (for example limit switches).
- Use only power supply units that will not be damaged by regeneration conditions.
- Use a braking resistor controller, if necessary.

Failure to follow these instructions can result in injury or equipment damage.

CAUTION**DAMAGE TO CONTACTS**

The connection for the controller supply voltage at the product does not have an inrush current limitation. If the voltage is switched on by means of switching (hot plugging) of contacts, damage to the contacts or contact welding may result.

- Use a power supply unit that limits the peak value of the output current to a value permissible for the contact.
- Switch the power input of the power supply unit instead of the output voltage.

Failure to follow these instructions can result in equipment damage.

▲ CAUTION**DAMAGE TO SYSTEM COMPONENTS AND LOSS OF CONTROL**

Interruptions of the negative connection of the controller supply voltage can cause excessively high voltages at the signal connections.

- Do not interrupt the negative connection between the power supply unit and load with a fuse or switch.
- Verify correct connection before switching on.
- Do not connect the controller supply voltage or change its wiring while the is supply voltage present..

Failure to follow these instructions can result in injury or equipment damage.

Pin assignment

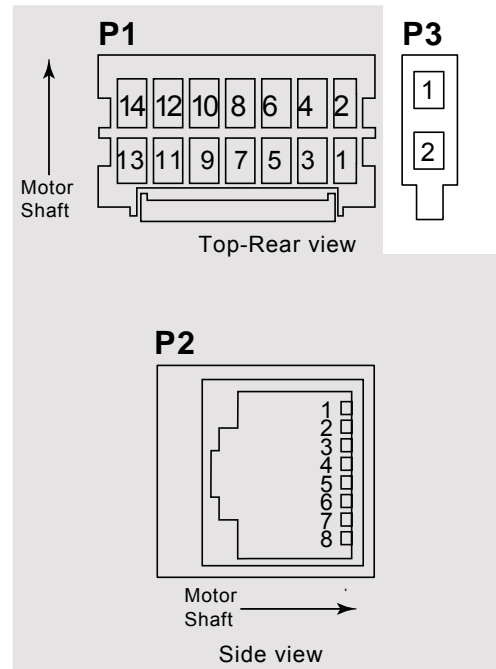

Figure 6.2: Pin Assignment supply voltage

Signal	Function	Pin number	Cable option wire color
VDC	Supply voltage	1	Red
GND	Reference potential to VDC	2	Black

Wiring/cable specifications

It is recommended that shielded twisted pair cabling be used for the supply voltage VDC connection.

- ▶ Verify that wiring, cables and connected interfaces meet the PELV requirements.
- ▶ Note the specified technical data.
- ▶ Note the information provided in chapters 5.1 “External power supply units” and 5.2 “Ground design”.
- ▶ Install fuses for the power supply cable accordance with the selected conductor cross section / wire gauge (note the inrush currents).

Length [ft (m)]	10 (3.0)	25 (7.6)	50 (15.2)	75 (22.9)	100 (30.5)
Amps (peak)	Minimum AWG (mm²)				
1	20 (0.5)	20 (0.5)	18 (0.75)	18 (0.75)	18 (0.75)
2	20 (0.5)	18 (0.75)	16 (1.5)	14 (2.5)	14 (2.5)
3	18 (0.75)	16 (1.5)	14 (2.5)	12 (4.0)	12 (4.0)
4	18 (0.75)	16 (1.5)	14 (2.5)	12 (4.0)	12 (4.0)

Connecting the cable The connector mate is a wire crimp locking type pluggable connector. The wire gauge is determined by the length of the conductor and the amount of current required.

To interface:

- ▶ Strip 0.25" (6.0 mm) insulation.
- ▶ Crimp pin onto wire end using manufacturer crimp tool
- ▶ Insert into designated pin of the connector shell
- ▶ Insert into P3 socket

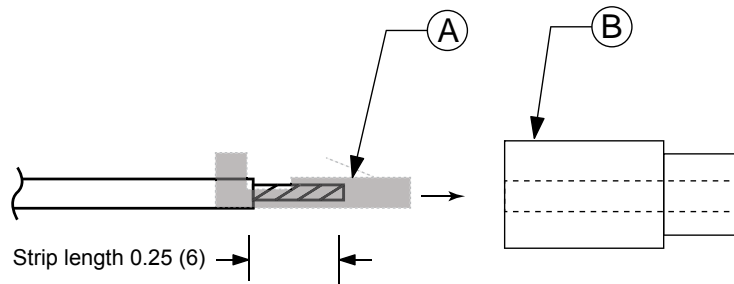

(A) **Crimp pins:** Tyco 794610-1

(B) **Shell:** Tyco 794617-2

Figure 6.3: Connecting supply voltage VDC wiring



To simplify connectivity, pre-assembled prototype development cables and connector kits with small quantity crimp pins and connector shells are available. See Chapter 10: Accessories for ordering information.

6.3.3 Connection of the I/O interface

Pin assignments

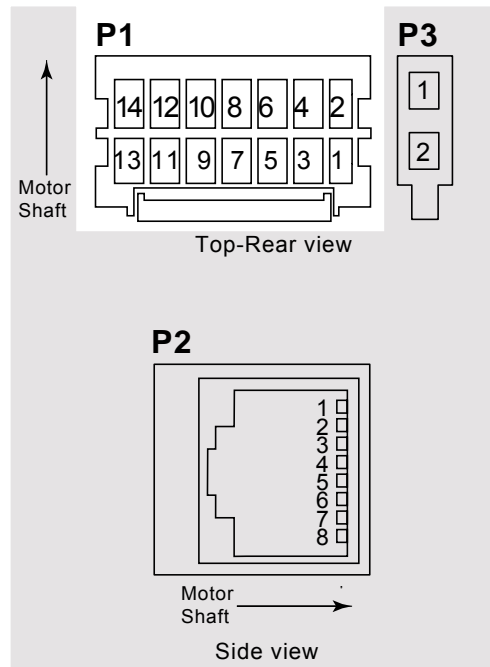

Figure 6.4: I/O interface pin assignments

Pin	Signal	Function	Cable option wire color	Twisted Pair #
1	IO POWER	+24 VDC input for sourcing outputs	Red	1
2	IO GROUND	IO ground - common with Supply Voltage VDC return,	Black	
3	IO1	General purpose I/O point #1	Orange	2
4	IO2	General purpose I/O point #2	Black	
5	IO3	General purpose I/O point #3	Brown	3
6	IO4	General purpose I/O point #4	Black	
7 ¹⁾	N/C	Not connected	Yellow	4
8 ¹⁾			Black	
9 ¹⁾			Blue	5
10 ¹⁾			Black	
11	CAPT/TRIP	Capture input/ trip output point	Green	6
12	ANALOG IN	Analog input	Black	
13	AUX POWER	Auxiliary supply voltage	White	7
14	AUX GROUND	Auxiliary supply return - common with Supply Voltage VDC return,	Black	

- 1) Pins in the gray shaded area are not connected, if using the cable option these may be left floating.

Wiring/cable specifications

- Shielded cable
- Twisted-pair cables
- Grounding of the shield at both ends

Max cable length ¹⁾	feet (m)	328 (100)
Minimum conductor cross section	AWG (mm ²)	24 (0,14)
Maximum conductor cross section	AWG (mm ²)	20 (0.6)
Stripping length	inches (mm)	0.25 (6.0)

- 2) The length depends on the conductor cross section and the driver circuit used

- ▶ Use equipotential bonding conductors.
- ▶ Verify that wiring, cables and connected interfaces meet the PELV requirements.

Connecting the cable The connector mate is a clamp type terminal strip.

To interface:

- ▶ Strip 0.25" (6.0 mm) insulation.
- ▶ Crimp pin onto wire end using manufacturer crimp tool
- ▶ Insert into designated pin of the connector shell
- ▶ Insert into P1 socket

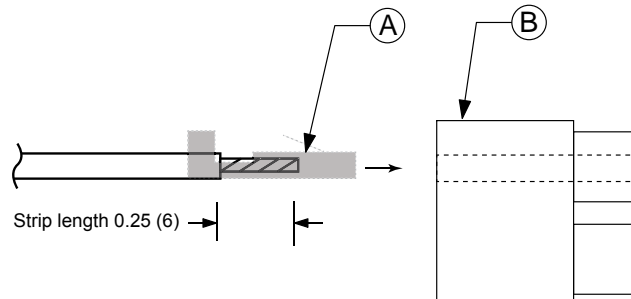

(A) **Crimp pins:** JST# SPH-001T-P0.5L

(B) **Shell:** JST# PADP-14V-1-S



Figure 6.5: Connecting I/O interface wiring

To simplify connectivity, pre-assembled prototype development cables and connector kits with small quantity crimp pins and connector shells are available. See Chapter 10: Accessories for ordering information.

Input equivalent circuits

When configured as inputs, the general purpose I/O may be interfaced as sinking or sourcing as determined by the hardware interface method and the software I/O parameter configuration.

Grounding for I/O is common with system ground.

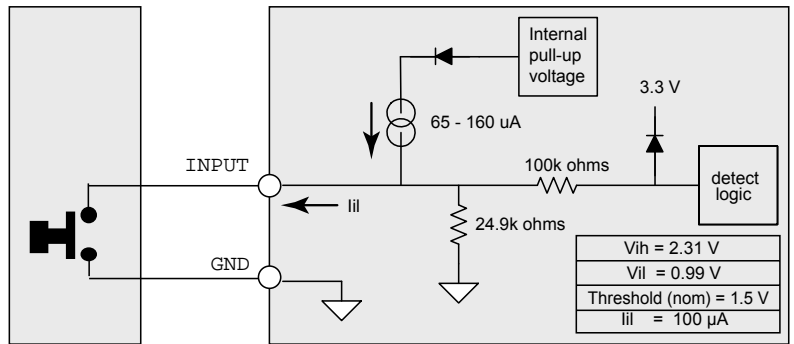

Figure 6.6: Switched sinking input

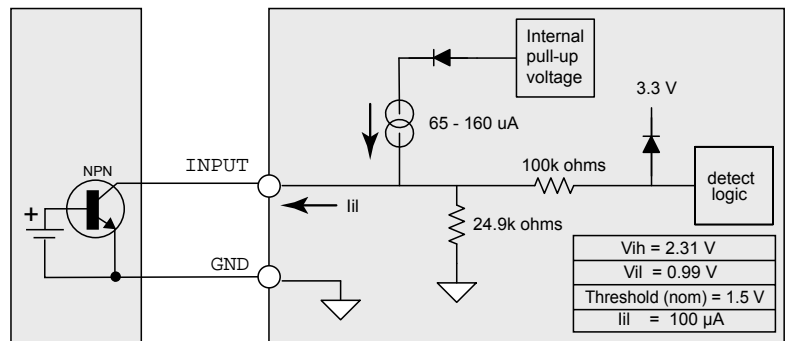

Figure 6.7: NPN sinking input

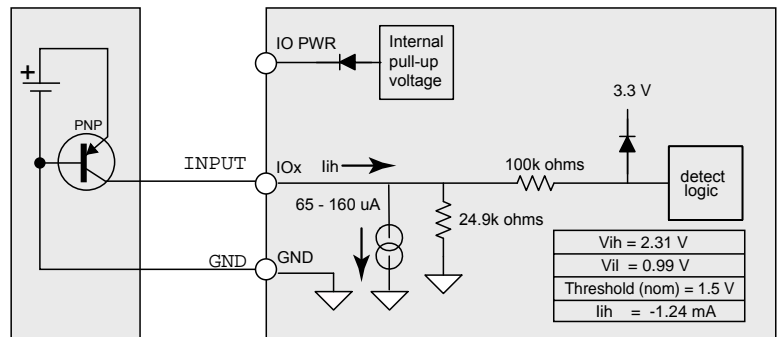

Figure 6.8: PNP sourcing input

Output equivalent circuits when configured as outputs, the general purpose I/O may be interfaced as sinking or sourcing as determined by the hardware interface method and the software I/O parameter configuration.

Grounding for I/O is common with system ground.

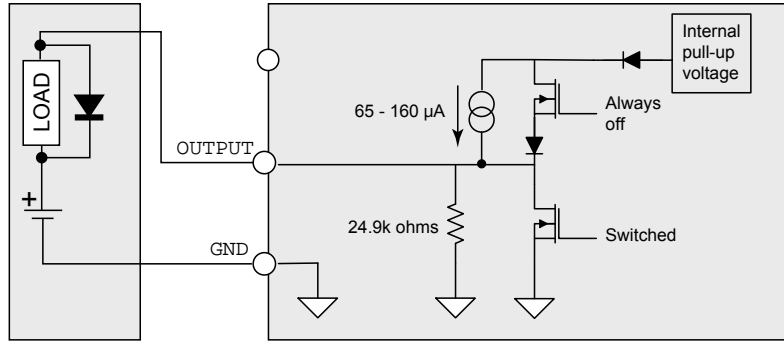

Figure 6.9: Sinking output to an inductive load

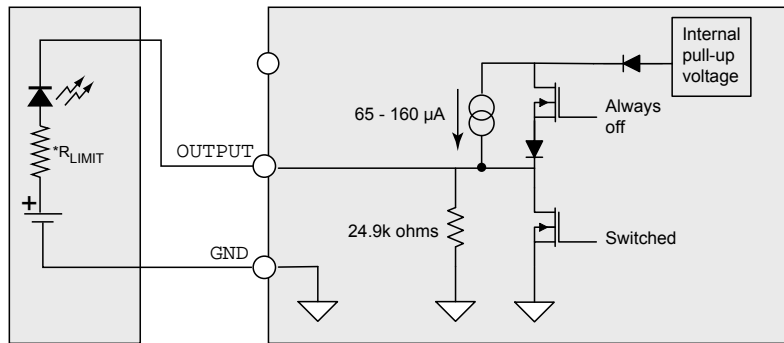

Figure 6.10: Sinking output to an LED

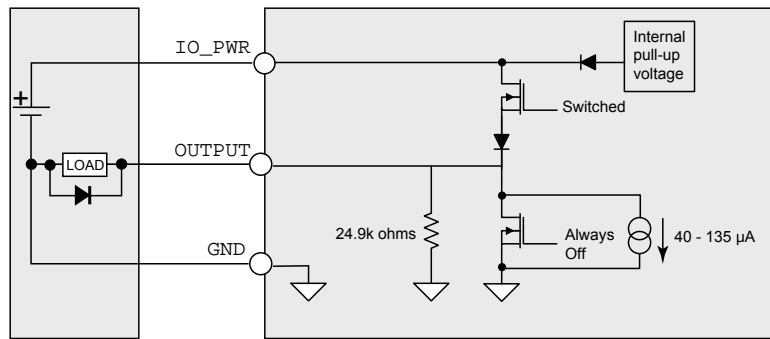

Figure 6.11: Sourcing output to inductive lo

Capture/Trip I/O The Capture/Trip I/O point is TTL level, configurable as a Capture input or a Trip output

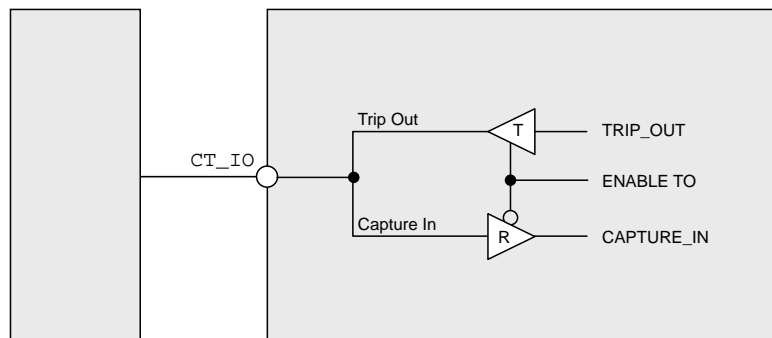

Figure 6.12: Capture/Trip I/O equivalent circuit

Analog input The Analog input may be interfaced at the following levels, which are configured in software:

- 0 to 5V
- 0 to 10V
- 4 to 20 mA
- 0 to 20 mA

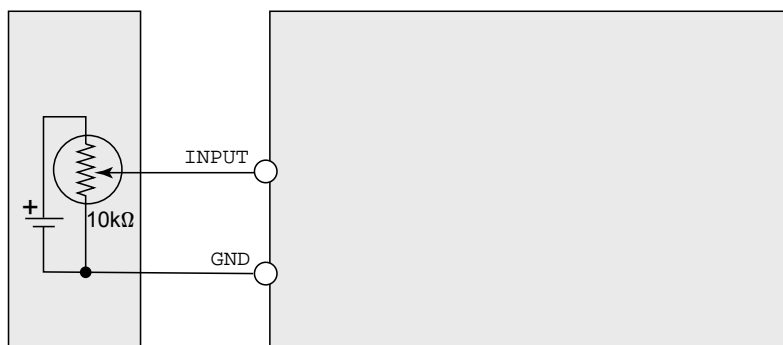

Figure 6.13: Analog input

6.3.4 Connection of the fieldbus interface

The fieldbus interface uses standard CAT5/6 cabling with RJ45 ends.

Pin assignments

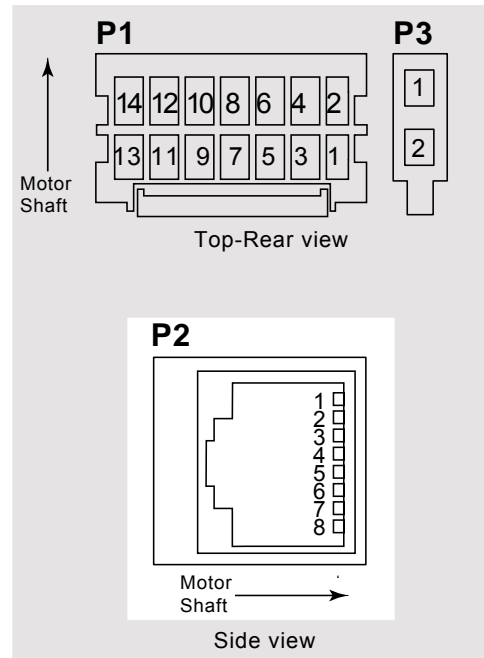

Figure 6.14: Fieldbus interface pin assignments

Pin	Signal	Function
1	TX+	Transmit plus
2	TX-	Transmit minus
3	RX+	Receive plus
4	N/C	Not connected
5	N/C	Not connected
6	RX-	Receive minus
7	N/C	Not connected
8	N/C	Not connected

Function The drive system is commissioned via the fieldbus interface and the commissioning software.

Connector style RJ45

Wiring/cable specifications

- CAT5/CAT6

Max cable length	feet (m)	328 (100)
------------------	----------	-----------

6.4 Checking wiring

Check the following:

- ▶ Did you properly install and connect all cables and connectors?
- ▶ Are all cables securely harnessed to provide strain relief on connectors?
- ▶ Are there any live, exposed cables?
- ▶ Did you properly connect the signal wires?

7 Commissioning

7

▲ WARNING

UNEXPECTED MOVEMENT

Drives may perform unexpected movements because of incorrect wiring, incorrect settings, incorrect data or other errors.

Interference (EMC) may cause unpredictable responses in the system.

- Carefully install the wiring in accordance with the EMC requirements.
- Do NOT operate the drive system with unknown settings or data.
- Perform a comprehensive commissioning test.

Failure to follow these instructions can result in death or serious injury.

▲ WARNING

UNINTENDED BEHAVIOR

The behavior of the drive system is governed by numerous stored data or settings. Unsuitable settings or data may trigger unexpected movements or responses to signals and disable monitoring functions.

- Do NOT operate the drive system with unknown settings or data.
- Verify that the stored data and settings are correct.
- When commissioning, carefully run tests for all operating states and potential fault situations.
- Verify the functions after replacing the product and also after making changes to the settings or data.
- Only start the system if there are no persons or obstructions in the hazardous area.

Failure to follow these instructions can result in death or serious injury.

▲ WARNING**ROTATING PARTS**

Rotating parts may cause injuries and may catch clothing or hair. Loose parts or parts that are unbalanced may be flung.

- Verify correct mounting and installation of all rotating parts.
- Use a cover to help protect against rotating parts.

Failure to follow these instructions can result in death or serious injury.

▲ WARNING**MOTOR WITHOUT BRAKING EFFECT**

If power outage and faults cause the power stage to be switched off, the motor is no longer stopped by the brake and may increase its speed even more until it reaches a mechanical stop.

- Verify the mechanical situation.
- If necessary, use a cushioned mechanical stop or a suitable brake.

Failure to follow these instructions can result in death or serious injury.

▲ WARNING**FALLING PARTS**

The motor may move as a result of the reaction torque; it may tip and fall.

- Mount the motor securely so it will not break loose during strong acceleration.

Failure to follow these instructions can result in death or serious injury.

▲ CAUTION**HOT SURFACES**

Depending on the operation, the surface may heat up to more than 100°C (212°F).

- Do not allow contact with the hot surfaces.
- Do not allow flammable or heat-sensitive parts in the immediate vicinity.
- Consider the measures for heat dissipation described.
- Check the temperature during test runs.

Failure to follow these instructions can result in injury or equipment damage.

7.1 Preparing for commissioning

The following tests are required before commissioning:

- ▶ The device may be commissioned in system or out of system.
- ▶ Only supply voltage V_{DC} and the Fieldbus interface connections are required for commissioning.
- ▶ Ensure that this chapter is read in its entirety, as many setup parameters are mode-specific.

For commissioning and programming, a PC with the TCP/IP Configuration Utility.

7.1.1 Installing the TCP/IP Configuration Utility

- PC running Windows XP SP3 or greater.
- ▶ Download and install the TCP/IP Configuration Utility from the internet at <http://www.schneider-electric-motion.us>.
- ▶ Connect the Ethernet cable to your PC and Lexium MDrive.
- ▶ Open the TCP/IP Configuration Utility.
- ▶ Browse to the Setup Tab.
- ▶ Apply power to the MDrive.
- ▶ Connect to the device using the default IP address 192.168.33.1.
- ◁ Verify connection status on the utility status bar.
- ▶ The device is ready to be commissioned.

7.2 Commissioning fieldbus parameters

For a complete reference of setup parameters see the MCode Programming and Reference manual available on the internet at:

<http://www.schneider-electric-motion.us>

7.2.1 IP Address and subnet mask

In order to set up the MDrive, you must first connect the utility configuration port by connecting to the default IP 192.168.33.1:503 to set up the IP and Subnet Mask. The gateway IP address is not required.

If you are on a corporate network, you may need to check with your IT department to obtain a block of private IP addresses so as not to conflict with computers and other devices on the network.

The assigned IP address should always be within the IPv4 Private Network block (192.168.0.0 — 192.168.255.255).

MCode/TCP will always use port 503 and may communicate via TCP or UDP interchangeably. The applications for MODBUS/TCP may be set via the TCP/IP Configuration Tools and is available at IP 192.168.33.1:502.

Once configured, you may connect to IP address you configured.

The screenshot shows the 'E.I.P.' configuration tab with the following fields and controls:

- MAC Address:** 0, 80, 194, 210, 192, 206, Read
- IP Address /Subnet Mask/Alt. SEM Port:**
 - IP (DEC.): 192, 168, 33, 1, Write
 - Subnet Mask (DEC.): 255, 255, 0, 0, Write
 - Gateway IP (DEC.): 192, 168, 1, 200, Write
 - Alternate SEM Port: 503, Write
- Application Protocol:** EtherNet/IP, Set
- Broadcast (Retrieve IP and serial no. of units on the network):** UDP Broadcast, Clear
- Tftpd Server IP:** Write, Read, Get local IP
- Ethernet Upgrade File Name:** Browse & set file name, Write, Read
- TCP/IP App Ver.:** Read
- Navigation:** Manual, SEM Port, MODBUS, Config, E.I.P.

Figure 7.1: Configuration tab

8 Operation

8

The chapter “Operation” describes the basic functions of the drive.

8.1 Basics

8.1.1 Overview

The MDrive Hybrid EtherNet/IP operates as an adapter class device on an EtherNet/IP network

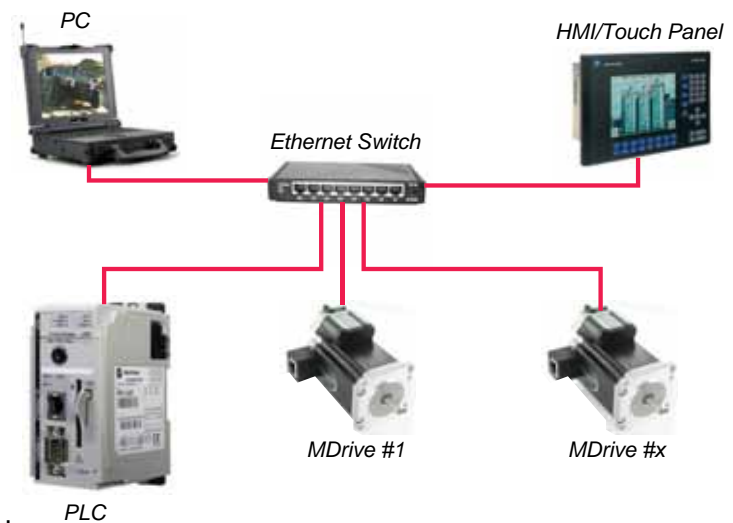

Figure 8.1: EtherNet/IP network

The MDrive functions are controlled via manufacturer specific EtherNet/IP object classes to:

- Index the motor to a specified relative or absolute position.
- Slew the motor at a specified velocity
- Set motor run/hold current
- Configure the function of the I/O points.
- Configure the operation of Hybrid Motion Technology.
- Poll the status of the device

Details of each object is located in the EtherNet/IP Fieldbus Manual, which may be downloaded at:

<http://www.schneider-electric-motion.us>

8.2 Supported objects

The MDrive Hybrid EtherNet/IP device is controlled by standard and manufacturer specific Objects.

Details of each object is located in the EtherNet/IP Fieldbus Manual, which may be downloaded at:

<http://www.schneider-electric-motion.us>

8.2.1 Standard objects

- Identity object (0x01)
- Assembly object (0x04)
- TCP object (0x05)
- Ethernet link object (0xF6)

8.2.2 Manufacturer specific objects

- Setup instructions (0x64)
- Miscellaneous instructions and flags (0x65)
- Motion instructions and flags (0x66)
- I/O instruction variables and flags (0x67)
- Position related instructions and flags (0x68)
- Encoder related instructions and flags (0x69)
- Hybrid Motion Technology related instructions (0x6A)

9 Diagnostics and troubleshooting

9

9.1 Fieldbus communication error diagnostics

A properly operating fieldbus is essential for evaluating operating and error messages.

Connections for fieldbus mode

If the product cannot be addressed via the fieldbus, first check the connections. The product manual contains the technical data of the device and information on network and device installation. Check the following:

- Power connections to the device
- Fieldbus cable and fieldbus wiring
- Network connection to the device

You can also use the TCP/IP Configuration Utility for troubleshooting.

Fieldbus function test

If the connections are correct, check the settings for the fieldbus addresses. After correct configuration of the transmission data, test fieldbus mode.

- 1) In addition to the master that knows the product via the EDS file and addressing, activate a bus monitor that, as a passive device, displays messages.
- 2) Switch the supply voltage off and on.
- 3) Observe the network messages that are generated briefly after the supply voltage is switched on. A bus monitor can be used to record the elapsed time between

Addressing, parameterization

If it is impossible to connect to a device, check the following:

- 1) Addressing: Each network device must have a unique IP address and the correct subnet mask.
- 2) Parameterization: "Vendor ID" and "Product Code" must match the values stored in the EDS file.

9.2 Status LEDs

The MDrive Hybrid with Ethernet has two dual-color (red/green) LEDs visible from the back of the drive to give status and error indication of the EtherNet/IP connection.

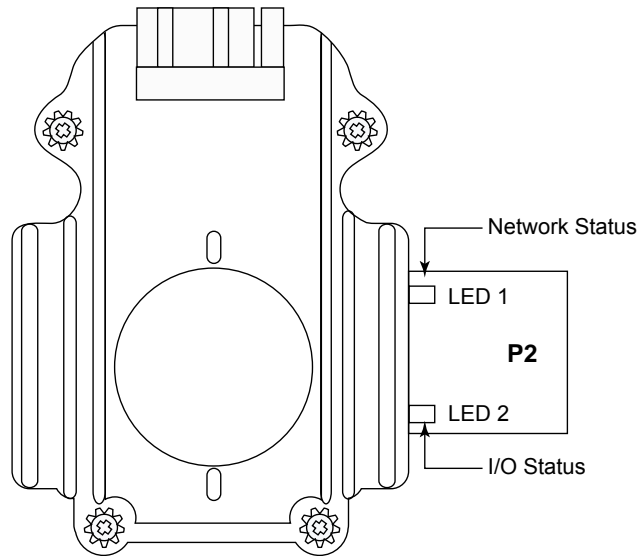

Figure 9.1: Status indicator LEDs

Color	State	Description
LED 1 – Network status		
None	Off	No power, no Ethernet connection
Red	Solid	Unrecoverable fault
	Flashing	Recoverable fault or I/O connection timed out
Green	Solid	Normal runtime operation (I/O connection allocated)
	Flashing	Device is idle or not allocated to a client (PLC)
Red/green	Alternating	Power-up self test in progress
LED 2 – I/O status		
None	Off	No power
Red	Solid	Unrecoverable fault
	Flashing	Minor, recoverable fault
Green	Solid	I/O connection established
	Flashing	Standby, no I/O connection established
Red/green	Alternating	Power-up self test in progress

10 Accessories and spare parts

10

10.1 Accessories

Source commissioning software The latest version of the commissioning software is available for download from the internet:

<http://www.schneider-electric-motion.us>

Quick Start Kit Contains all cables needed to interface to the device with manuals and software on CD. Kits are specified by adding a “K-” to the beginning of the part number.

Description	Part number
Quick Start Kit contains	K-MAI3CIR23**
Power cable	PD02-2300-FL3
I/O cable	PD14-2334-FL3
RJ45 Ethernet 7' (2.0 m)	—
Printed Quick Reference	QR-ETH
CD	IMS-CD200-000

Prototype development cables

Description	Part number
10' (3.0 m) twisted pair to supply voltage VDC interface	PD02-2300-FL3
10' (3.0 m) shielded twisted pair to I/O interface	PD14-2334-FL3

Mating connector kits

Description	Part number
2-pin Tyco locking wire crimp 5 ea.	CK-04
14-pin JST locking wire crimp 5 ea.	CK-09

Drive Protection Module

Description	Part number
Drive protection module allows for switching DC power	DPM75

Page intentionally left blank

11 Service, maintenance and disposal

11

▲ CAUTION

DAMAGE TO SYSTEM COMPONENTS AND LOSS OF CONTROL

Interruptions of the negative connection of the controller supply voltage can cause excessively high voltages at the signal connections.

- Do not interrupt the negative connection between the power supply unit and load with a fuse or switch.
- Verify correct connection before switching on.
- Do not connect the controller supply voltage or change its wiring while the is supply voltage present..

Failure to follow these instructions can result in injury or equipment damage.

▲ CAUTION

RISK OF INJURY WHEN REMOVING CIRCUIT BOARD PLUGS

- When removing them note that the connectors must be unlocked.
 - Supply voltage VDC: unlock by removing locking screws
 - I/O interface: unlock with locking tabs
- Always hold the plug to remove it (not the cable).

Failure to follow these instructions can result in injury or equipment damage.



The product may only be repaired by a certified customer service center. No warranty or liability is accepted for repairs made by unauthorized persons.

11.1 Service address



If you cannot resolve an error yourself please contact your sales office. Have the following details available:

- Nameplate (type, identification number, serial number)
- Type of error (such as LED flash code or error number)
- Previous and concomitant circumstances
- Your own assumptions concerning the cause of the error

Also include this information if you return the product for inspection or repair. Note that units being returned for inspection or repair must be accompanied by a Return Material Authorization (RMA).

Technical or applications support is available via the internet at:

<http://www.schneider-electric-motion.us>

11.2 Maintenance

Check the product for pollution or damage at regular intervals, depending on the way you use it.

11.3 Replacing units

▲ WARNING

UNINTENDED BEHAVIOR

The behavior of the drive system is governed by numerous stored data or settings. Unsuitable settings or data may trigger unexpected movements or responses to signals and disable monitoring functions.

- Do NOT operate the drive system with unknown settings or data.
- Verify that the stored data and settings are correct.
- When commissioning, carefully run tests for all operating states and potential fault situations.
- Verify the functions after replacing the product and also after making changes to the settings or data.
- Only start the system if there are no persons or obstructions in the hazardous area.

Failure to follow these instructions can result in death or serious injury.

Only start the system if there are no persons or obstructions in the hazardous area.

- ▶ Switch off all supply voltages. Verify that no voltages are present (safety instructions).
- ▶ Label all connections and uninstall the product.
- ▶ Note the identification number and the serial number shown on the product nameplate for later identification.
- ▶ Install the new product as per chapter 6 “Installation”
- ▶ Commission the product as per chapter 7 “Commissioning”.

11.4 Shipping, storage, disposal

Removal Removal procedure:

- ▶ Switch off the power supply.
- ▶ Disconnect the power supply.
- ▶ Pull out all plugs.
- ▶ Remove the product from the system.

Shipping The product must be protected against shocks during transportation. If possible, use the original packaging for shipping.

Storage The product may only be stored in spaces where the specified permissible ambient conditions for room temperature and humidity are met. Protect the product from dust and dirt.

Disposal The product consists of various materials that can be recycled and must be disposed of separately. Dispose of the product in accordance with local regulations.

Page intentionally blank

12 Glossary

12

12.1 Units and conversion tables

The value in the specified unit (left column) is calculated for the desired unit (top row) with the formula (in the field).

Example: conversion of 5 meters [m] to yards [yd]
 $5 \text{ m} / 0.9144 = 5.468 \text{ yd}$

12.1.1 Length

	in	ft	yd	m	cm	mm
in	—	/ 12	/ 36	* 0.0254	* 2.54	* 25.4
ft	* 12	—	/ 3	* 0.30479	* 30.479	* 304.79
yd	* 36	* 3	—	* 0.9144	* 91.44	* 914.4
m	/ 0.0254	/ 0.30479	/ 0.9144	—	* 100	* 1000
cm	/ 2.54	/ 30.479	/ 91.44	/ 100	—	* 10
mm	/ 25.4	/ 304.79	/ 914.4	/ 1000	/ 10	—

12.1.2 Mass

	lb	oz	slug	kg	g
lb	—	* 16	* 0.03108095	* 0.4535924	* 453.5924
oz	/ 16	—	* $1.942559 \cdot 10^{-3}$	* 0.02834952	* 28.34952
slug	/ 0.03108095	* $1.942559 \cdot 10^{-3}$	—	* 14.5939	* 14593.9
kg	/ 0.453592370	/ 0.02834952	/ 14.5939	—	* 1000
g	/ 453.592370	/ 28.34952	/ 14593.9	/ 1000	—

12.1.3 Force

	lb	oz	p	dyne	N
lb	—	* 16	* 453.55358	* 444822.2	* 4.448222
oz	/ 16	—	* 28.349524	* 27801	* 0.27801
p	/ 453.55358	/ 28.349524	—	* 980.7	* $9.807 \cdot 10^{-3}$
dyne	/ 444822.2	/ 27801	/ 980.7	—	/ $100 \cdot 10^3$
N	/ 4.448222	/ 0.27801	/ $9.807 \cdot 10^{-3}$	* $100 \cdot 10^3$	—

12.1.4 Power

	HP	W
HP	—	* 745.72218
W	/ 745.72218	—

12.1.5 Rotation

	min ⁻¹ (RPM)	rad/s	deg./s
min ⁻¹ (RPM)	—	* $\pi / 30$	* 6
rad/s	* $30 / \pi$	—	* 57.295
deg./s	/ 6	/ 57.295	—

12.1.6 Torque

	lb-in	lb-ft	oz-in	Nm	kp-m	kp-cm	dyne-cm
lb-in	—	/ 12	* 16	* 0.112985	* 0.011521	* 1.1521	* $1.129 \cdot 10^6$
lb-ft	* 12	—	* 192	* 1.355822	* 0.138255	* 13.8255	* $13.558 \cdot 10^6$
oz-in	/ 16	/ 192	—	* $7.0616 \cdot 10^{-3}$	* $720.07 \cdot 10^{-6}$	* $72.007 \cdot 10^{-3}$	* 70615.5
Nm	/ 0.112985	/ 1.355822	/ $7.0616 \cdot 10^{-3}$	—	* 0.101972	* 10.1972	* $10 \cdot 10^6$
kp-m	/ 0.011521	/ 0.138255	/ $720.07 \cdot 10^{-6}$	/ 0.101972	—	* 100	* $98.066 \cdot 10^6$
kp-cm	/ 1.1521	/ 13.8255	/ $72.007 \cdot 10^{-3}$	/ 10.1972	/ 100	—	* $0.9806 \cdot 10^6$
dyne-cm	/ $1.129 \cdot 10^6$	/ $13.558 \cdot 10^6$	/ 70615.5	/ $10 \cdot 10^6$	/ $98.066 \cdot 10^6$	/ $0.9806 \cdot 10^6$	—

12.1.7 Moment of inertia

	lb-in ²	lb-ft ²	kg-m ²	kg-cm ²	kp-cm-s ²	oz-in ²
lb-in ²	—	/ 144	/ 3417.16	/ 0.341716	/ 335.109	* 16
lb-ft ²	* 144	—	* 0.04214	* 421.4	* 0.429711	* 2304
kg-m ²	* 3417.16	/ 0.04214	—	* $10 \cdot 10^3$	* 10.1972	* 54674
kg-cm ²	* 0.341716	/ 421.4	/ $10 \cdot 10^3$	—	/ 980.665	* 5.46
kp-cm-s ²	* 335.109	/ 0.429711	/ 10.1972	* 980.665	—	* 5361.74
oz-in ²	/ 16	/ 2304	/ 54674	/ 5.46	/ 5361.74	—

12.1.8 Temperature

	°F	°C	K
°F	—	(°F - 32) * 5/9	(°F - 32) * 5/9 + 273.15
°C	°C * 9/5 + 32	—	°C + 273,15
K	(K - 273.15) * 9/5 + 32	K - 273.15	—

12.1.9 Conductor cross section

AWG	1	2	3	4	5	6	7	8	9	10	11	12	13
mm²	42.4	33.6	26.7	21.2	16.8	13.3	10.5	8.4	6.6	5.3	4.2	3.3	2.6
AWG	14	15	16	17	18	19	20	21	22	23	24	25	26
mm²	2.1	1.7	1.3	1.0	0.82	0.65	0.52	0.41	0.33	0.26	0.20	0.16	0.13

12.2 Terms and Abbreviations

AC Alternating current

Acceleration The time rate of change of velocity with respect to a fixed reference frame. The commanded step rate is started at a base velocity and accelerated at a slew velocity at a defined and controlled rate or rate of changes.

ASCII American Standard Code for Information Interchange. Standard for coding of characters.

Back Electro-Motive Force (Back EMF) Also known as regeneration current, the reversed bias generated by rotation of the magnetic field across a stator's windings. Sometimes referred to as counter EMF.

CAN (Controller Area Network), standardized open fieldbus as per ISO 11898, allows drives and other devices from different manufacturers to communicate.

CANopen CANopen is a CAN-based higher layer protocol. It was developed as a standardized embedded network with highly flexible configuration capabilities. CANopen was designed motion oriented machine control networks, such as handling systems. It is used in many various fields, such as medical equipment, off-road vehicles, maritime electronics, public transportation, building automation, etc

Closed Loop System In motion control, this term describes a system wherein a velocity or position (or both) sensor is used to generate signals for comparison to desired parameters. For cases where loads are not predictable, the closed loop feedback from an external encoder to the controller may be used for stall detection, position maintenance or position verification.

Daisy Chain This term is used to describe the linking of several devices in sequence, such that a single signal stream flows through one device and on to another

<i>DC</i>	Direct current
<i>Deadband</i>	A range of input signals for which there is no system response.
<i>Default value</i>	Factory setting.
<i>Detent Torque</i>	The periodic torque ripple resulting from the tendency of the magnetic rotor and stator poles to align themselves to positions of minimal reluctance. The measurement is taken with all phases de-energized.
<i>Direction of rotation</i>	Rotation of the motor shaft in a clockwise or counterclockwise direction of rotation. Clockwise rotation is when the motor shaft rotates clockwise as you look at the end of the protruding motor shaft.
<i>DOM</i>	The Date of manufacturing on the nameplate of the device is shown in the format DD.MM.YY, e.g. 31.12.06 (December 31, 2006).
<i>Duty Cycle</i>	For a repetitive cycle, the ratio of on time to total cycle time.
<i>EMC</i>	Electromagnetic compatibility
<i>Encoder</i>	Sensor for detection of the angular position of a rotating component. The motor encoder shows the angular position of the rotor.
<i>Error class</i>	Classification of errors into groups. The different error classes allow for specific responses to faults, e.g. by severity.
<i>Fatal error</i>	In the case of fatal error, the drive is not longer able to control the motor, so that an immediate switch-off of the drive is necessary.
<i>Fault</i>	Operating state of the drive caused as a result of a discrepancy between a detected (computed, measured or signaled) value or condition and the specified or theoretically correct value or condition.
<i>Fault reset</i>	A function used to restore the drive to an operational state after a detected fault is cleared by removing the cause of the fault so that the fault is no longer active (transition from state "Fault" to state "Operation Enable").
<i>Forcing</i>	Forcing switching states of inputs/outputs. Forcing switching states of inputs/outputs.
<i>Full Duplex</i>	The transmission of data in two directions simultaneously. For example, a telephone is a full-duplex device because both parties can talk at the same time.

<i>Ground Loop</i>	A ground loop is any part of the DC return path (ground) that has more than one possible path between any two points.
<i>Half Duplex</i>	A ground loop is any part of the DC return path (ground) that has more than one possible path between any two points.
<i>Half Step</i>	This term means that the motor shaft will move a distance of 0.9 degree (400 steps per shaft revolution) instead of moving 1.8 degree per digital pulse.
<i>Hybrid Motion Technology™ (HMT)</i>	A motor control technology representing a new paradigm in brushless motor control. By bridging the gap between stepper and servo performance, HMT offers system integrators a third choice in motion system design.
<i>Hybrid Motors</i>	Hybrid stepper motors feature the best characteristics of PM and VR motors. Hybrid steppers are best suited for industrial applications because of high static and run torque, a standard low step angle of 1.8°, and the ability to Microstep. Hybrid stepper motors offer the ability to precisely position a load without using a closed-loop feedback device such as an encoder.
<i>Holding Torque</i>	The maximum torque or force that can be externally applied to a stopped, energized motor without causing the rotor to rotate continuously. This is also called “static torque”.
<i>I/O</i>	Inputs/outputs
<i>Inc</i>	Increments
<i>Index pulse</i>	Signal of an encoder to reference the rotor position in the motor. The encoder returns one index pulse per revolution.
<i>Inertia</i>	A measure of an object’s resistance to a change in velocity. The larger an object’s inertia, the greater the torque required to accelerate or decelerate it. Inertia is a function of an object’s mass and shape. For the most efficient operation, the system-coupling ratio should be selected so that the reflected inertia of the load is equal to or no greater than 10 times the rotor inertia of the stepper motor.
<i>Inertia (Reflected)</i>	Inertia as seen by the stepper motor when driving through a speed change, reducer or gear train.
<i>Lag</i>	The amount (in full motor steps) that the rotor lags the stator. Lag conditions are caused by loading on the motor shaft, as during transient loading or rapid acceleration.

<i>Lead</i>	The amount (in full motor steps) that the rotor leads the stator. Lead conditions are caused by an overhauling load, as during periods of rapid deceleration.
<i>Limit switch</i>	Switch that signals overtravel of the permissible range of travel.
<i>Load</i>	Any external resistance (static or dynamic) to motion that is applied to the motor.
<i>Locked rotor</i>	When the lag/lead limit is reached, a timer starts a countdown that is determined by the user. The locked rotor will assert itself by triggering a flag and, depending on the selected mode, by disabling the output bridge.
<i>Loss of synchronization</i>	In traditional stepper systems, when the lead/lag relationship of the rotor and stator reaches two full motor steps, the alignment of the magnetic fields is broken and the motor will stall in a freewheeling state. Hybrid Motion Technology eliminates this.
<i>Microstepping</i>	A control electronic technique that proportions the current in a stepper motor's windings to provide additional intermediate positions between poles. Produces smooth rotation over a wide range and high positional resolution. Typically, step resolutions range from 400 to 51,200 steps per shaft revolution.
<i>Motor phase current</i>	The available torque of a stepper motor is determined by the motor phase current. The higher the motor phase current the higher the torque.
<i>Multidrop</i>	A communications configuration in which several devices share the same transmission line, although generally only one may transmit at a time. This configuration usually uses some kind of polling mechanism to address each connected device with a unique address code.
<i>NEMA</i>	The acronym for the National Electrical Manufacturer's Association, an organization that sets standards for motors and other industrial electrical equipment.
<i>Node guarding</i>	Monitoring of the connection with the slave at an interface for cyclic data traffic.
<i>Open Loop System</i>	An open loop motion control system is where no external sensors are used to provide position or velocity feedback signals, such as encoder feedback of position.

<i>Opto-Isolated</i>	A method of sending a signal from one piece of equipment to another without the usual requirement of common ground potentials. The signal is transmitted optically with a light source (usually a Light Emitting Diode) and a light sensor (usually a photo-sensitive transistor). These optical components provide electrical isolation.
<i>Parameter</i>	Device data and values that can be set by the user.
<i>Persistent</i>	Indicates whether the value of the parameter remains in the memory after the device is switched off.
<i>PLC</i>	Programmable logic controller
<i>Position lead/lag</i>	The HMT circuitry continually tracks the position lead or lag error, and may use it to correct position.
<i>Position make-up</i>	When active, the position make-up can correct for position errors occurring due to transient loads. The lost steps may be interleaved with incoming steps, or reinserted into the profile at the end of a move.
<i>Power stage</i>	The power stage controls the motor. The power stage generates currents for controlling the motor on the basis of the positioning signals from the controller.
<i>Pull-In Torque</i>	This is the maximum torque the stepper motor can develop when instantaneously started at that speed.
<i>Pull-Out Torque</i>	This is the maximum torque that the stepper can develop once an acceleration profile has been used to “ramp” it to the target speed.
<i>Quick Stop</i>	Function used to enable fast deceleration of the motor via a command or in the event of a malfunction.
<i>Resolution</i>	The smallest positioning increment that can be achieved.
<i>Resonance</i>	The frequency that a stepper motor system may begin to oscillate. Primary resonance frequency occurs at about one revolution per second. This oscillation will cause a loss of effective torque and may result in loss of synchronism. The designer should consider reducing or shifting the resonance frequency by utilizing half step or micro-step techniques or work outside the primary resonance frequency.
<i>Rotor</i>	The moving part of the motor, consisting of the shaft and the magnets. These magnets are similar to the field winding of a brush type DC motor

<i>. Rotor Inertia</i>	The rotational inertia of the rotor and shaft.
<i>RS485</i>	Fieldbus interface as per EIA-485 which enables serial data transmission with multiple devices.
<i>Sinking Current</i>	Refers to the current flowing into the output of the chip. This means that a device connected between the positive supply and the chip output will be switched on when the output is low.
<i>Slew</i>	The position of a move profile where the motor is operating at a constant velocity
<i>Sourcing Current</i>	Refers to the current flowing out of the output of the chip. This means that a device connected between the chip output and the negative supply will be switched on when the output is high.
<i>Stall detection</i>	Stall detection monitors whether the index pulse is always correctly triggered at the same angle position of the motor shaft.
<i>Stator</i>	The stationary part of the motor. Specifically, it is the iron core with the wire winding in it that is pressed into the shell of the frame. The winding pattern determines the voltage constant of the motor.
<i>Torque ramp</i>	Deceleration of the motor with the maximum possible deceleration, which is only limited by the maximum permissible current. The higher the permissible braking current, the stronger the deceleration. Because energy is recovered up depending on the coupled load, the voltage may increase to excessively high values. In this case the maximum permissible current must be reduced.
<i>Variable current control</i>	When active, variable current control will control the motor current as such to maintain the torque and speed on the load to what is required by the profile. This leads to reduced motor heating and greater system efficiency.
<i>Warning</i>	If not used within the context of safety instructions, a warning alerts to a potential problem detected by a monitoring function. A warning is not a fault and does not cause a transition of the operating state. Warnings belong to error class 0.
<i>Watchdog</i>	Unit that monitors cyclic basic functions in the product. Power stage and outputs are switched off in the event of faults.
<i>Zero crossing</i>	The point in a stepper motor where one phase is at 100% current and the other is at 0% current.

WARRANTY

TWENTY-FOUR (24) MONTH LIMITED WARRANTY

IMS Schneider Electric Motion USA warrants only to the purchaser of the Product from IMS Schneider Electric Motion USA (the "Customer") that the product purchased from IMS Schneider Electric Motion USA (the "Product") will be free from defects in materials and workmanship under the normal use and service for which the Product was designed for a period of 24 months from the date of purchase of the Product by the Customer. Customer's exclusive remedy under this Limited Warranty shall be the repair or replacement, at Company's sole option, of the Product, or any part of the Product, determined by IMS Schneider Electric Motion USA to be defective. In order to exercise its warranty rights, Customer must notify Company in accordance with the instructions described under the heading "Obtaining Warranty Service".

NOTE: MDrive Motion Control electronics are not removable from the motor in the field. The entire unit must be returned to the factory for repair.

This Limited Warranty does not extend to any Product damaged by reason of alteration, accident, abuse, neglect or misuse or improper or inadequate handling; improper or inadequate wiring utilized or installed in connection with the Product; installation, operation or use of the Product not made in strict accordance with the specifications and written instructions provided by IMS; use of the Product for any purpose other than those for which it was designed; ordinary wear and tear; disasters or Acts of God; unauthorized attachments, alterations or modifications to the Product; the misuse or failure of any item or equipment connected to the Product not supplied by IMS Schneider Electric Motion USA; improper maintenance or repair of the Product; or any other reason or event not caused by IMS Schneider Electric Motion USA.

IMS SCHNEIDER ELECTRIC MOTION USA HEREBY DISCLAIMS ALL OTHER WARRANTIES, WHETHER WRITTEN OR ORAL, EXPRESS OR IMPLIED BY LAW OR OTHERWISE, INCLUDING WITHOUT LIMITATION, ANY WARRANTIES OF MERCHANTABILITY OR FITNESS FOR ANY PARTICULAR PURPOSE. CUSTOMER'S SOLE REMEDY FOR ANY DEFECTIVE PRODUCT WILL BE AS STATED ABOVE, AND IN NO EVENT WILL IMS BE LIABLE FOR INCIDENTAL, CONSEQUENTIAL, SPECIAL OR INDIRECT DAMAGES IN CONNECTION WITH THE PRODUCT.

This Limited Warranty shall be void if the Customer fails to comply with all of the terms set forth in this Limited Warranty. This Limited Warranty is the sole warranty offered by IMS Schneider Electric Motion USA with respect to the Product. IMS Schneider Electric Motion USA does not assume any other liability in connection with the sale of the Product. No representative of IMS Schneider Electric Motion USA is authorized to extend this Limited Warranty or to change it in any manner whatsoever. No warranty applies to any party other than the original Customer.

IMS Schneider Electric Motion USA and its directors, officers, employees, subsidiaries and affiliates shall not be liable for any damages arising from any loss of equipment, loss or distortion of data, loss of time, loss or destruction of software or other property, loss of production or profits, overhead costs, claims of third parties, labor or materials, penalties or liquidated damages or punitive damages, whatsoever, whether based upon breach of warranty, breach of contract, negligence, strict liability or any other legal theory, or other losses or expenses incurred by the Customer or any third party.

OBTAINING WARRANTY SERVICE

If the Product was purchased from an IMS Schneider Electric Motion USA Distributor, please contact that Distributor to obtain a Returned Material Authorization (RMA). If the Product was purchased directly from IMS Schneider Electric Motion USA, please contact Customer Service at info@imshome.com or 860-295-6102 (Eastern Time Zone).

Customer shall prepay shipping charges for Products returned to IMS Schneider Electric Motion USA for warranty service and IMS Schneider Electric Motion USA shall pay for return of Products to Customer by ground transportation. However, Customer shall pay all shipping charges, duties and taxes for Products returned to IMS Schneider Electric Motion USA from outside the United States.

Schneider Electric Motion USA

370 North Main Street, P.O. Box 457

Marlborough, CT 06447 - U.S.A.

Tel. +00 (1) 860 295-6102 - Fax +00 (1) 860 295-6107

e-mail: info@imshome.com

<http://www.schneider-electric-motion.us>

© Schneider Electric Motion USA All Rights Reserved.
Product Disclaimer and most recent product information at
www.schneider-electric-motion.us.

V.1.000, 10.2011

IMS
INTELLIGENT MOTION
SYSTEMS, INC.

Schneider
 **Electric**