

## *Part I* *The Modular* *LYNX System*



- *Getting Started*
- *Connecting the LYNX System*
- *Mounting the LYNX System*
- *Powering the LYNX System*
- *The Communications Interface*
- *Configuring the Digital I/O*
- *The LYNX Control Module*
- *The LYNX Control Module (Combination)*
- *The Isolated Digital I/O Module*
- *The Differential Digital I/O Module*
- *The Combination Digital I/O Module*

# Table of Contents

<b>Section 1: Getting Started .....</b>	<b>1-5</b>
Section Overview .....	1-5
Getting Started .....	1-5
Included in the Package .....	1-5
User Provided Tools and Equipment Needed .....	1-6
Connecting the Power Supply .....	1-6
Connecting the Step Motor Driver .....	1-6
Motor Connections .....	1-6
Communications Wiring .....	1-6
Establishing Communications using the IMS LYNX Terminal .....	1-6
Testing the LYNX Setup .....	1-7
<b>Section 2: Connecting the LYNX System .....</b>	<b>1-9</b>
Section Overview .....	1-9
Connecting the System .....	1-9
<b>Section 3: Mounting the LYNX System .....</b>	<b>1-10</b>
Section Overview .....	1-10
Panel Mount .....	1-10
Din Rail Mounting Option .....	1-10
Included in the DIN Rail Mounting Kit .....	1-10
Mounting the LYNX System to a DIN Rail .....	1-10
<b>Section 4: Powering the LYNX System .....</b>	<b>1-12</b>
Section Overview .....	1-12
Wiring and Shielding .....	1-12
Rules of Wiring .....	1-12
Rules of Shielding .....	1-12
LYNX Control Module with IMS Driver .....	1-13
Stand-alone or with Optional I/O Modules .....	1-14
+12 to +75VDC Supply .....	1-14
+5 VDC Supply .....	1-14
Power Requirements .....	1-15
<b>Section 5: The Communications Interface .....</b>	<b>1-16</b>
Section Overview .....	1-16
Connecting the RS-232 Interface .....	1-16
Single Control Module System .....	1-16
Multiple Control Module System .....	1-17
Connecting the RS-485 Interface .....	1-20
Single Controller System .....	1-20
Multiple Controller System .....	1-21
LYNX Control Module Modes of Operation .....	1-23
Immediate Mode .....	1-23
Program Mode .....	1-23
EXEC Mode .....	1-23
LYNX Control Module Communication Modes .....	1-23
ASCII .....	1-23
Binary .....	1-24
<b>Section 6: Configuring the Digital I/O .....</b>	<b>1-25</b>
Section Overview .....	1-25
System I/O Availability by Module .....	1-25
The Isolated Digital I/O .....	1-26
Uses of the Isolated Digital I/O .....	1-26
The IOS Variable .....	1-27
Configuring an Input .....	1-28
Configuring the Digital Filtering .....	1-28
Configuring an Output .....	1-29
The IO Variable .....	1-29
Read/Write an I/O Group .....	1-30
The Differential I/O .....	1-31
The Clock Interface .....	1-31
Clock Types Defined .....	1-31
Configuring The Differential I/O - The IOS Variable .....	1-32
Configuring an Input .....	1-32
Setting the Digital Input Filtering for the Differential I/O .....	1-33
Configuring an Output .....	1-33

Typical Functions of the Differential I/O .....	1-34
Connecting and Using an Encoder .....	1-34
Translating the EUNIT Variable to a Dimension of Distance .....	1-35
Half Axis Operation (Follower) .....	1-36
One and a Half Axis Operation (RATIOE) .....	1-37
<b>Section 7: The LYNX Control Module (LX-CM100-000) .....</b>	<b>1-39</b>
Section Overview .....	1-39
Hardware Specifications .....	1-39
Environmental Specifications .....	1-39
Mechanical Specification .....	1-39
Connection Overview .....	1-40
Power Requirements .....	1-40
LED Indicators .....	1-41
Pin Assignment and Description .....	1-41
Switch Assignments .....	1-42
<b>Section 8: The LYNX Control Module (Combination) .....</b>	<b>1-43</b>
Section Overview .....	1-43
Hardware Specifications .....	1-43
Environmental Specifications .....	1-43
Mechanical Specification .....	1-43
Connection Overview .....	1-44
Power Requirements .....	1-44
LED Indicators .....	1-45
Pin Assignment and Description .....	1-45
Switch Assignments .....	1-46
<b>Section 9: The Isolated Digital I/O Module .....</b>	<b>1-47</b>
Section Overview .....	1-47
Hardware Specifications .....	1-47
Environmental Specification .....	1-47
Mechanical Specification .....	1-47
Connection Overview .....	1-48
Pin Assignments And Description .....	1-48
Switch Assignments And Description .....	1-49
Input Specifications .....	1-49
Input Filtering .....	1-50
Output Specifications .....	1-50
<b>Section 10: The Differential Digital I/O Module .....</b>	<b>1-51</b>
Section Overview .....	1-51
Hardware Specifications .....	1-51
Environmental Specification .....	1-51
Mechanical Specification .....	1-51
Connection Overview .....	1-52
Power Requirements .....	1-52
Pin Assignments And Description .....	1-53
Input Specifications .....	1-53
Input Filtering .....	1-54
Output Specifications .....	1-55

## List of Tables

Table 4.1: Power Requirements .....	1-15
Table 5.1: Wiring Connections: RS-232 Interface Single Control Module System .....	1-17
Table 5.2: Party Mode Address Configuration Switch Settings .....	1-18
Table 5.3: Connections and Settings Multiple Control Module System, RS-232 Interface .....	1-19
Table 5.4: RS-485 Interface Connections .....	1-20
Table 5.5: Party Mode Address Configuration Switch Settings .....	1-21
Table 5.6: RS-485 Interface Connections and Settings, Multiple Control Module System .....	1-22
Table 5.7: ASCII Mode Special Command Characters .....	1-24
Table 5.8: Binary Hex Codes .....	1-24
Table 6.1: System I/O Availability by Module .....	1-25
Table 6.2: IOS Variable Settings .....	1-27
Table 6.3: Digital Filter Settings for the Isolated I/O .....	1-28
Table 6.4: Binary State of Outputs .....	1-30
Table 6.5: The Four Clocks and Their Default Line Placement .....	1-31
Table 6.6: Digital Filter Settings for the Differential I/O .....	1-33

Table 7.1:	Power Requirements for the LYNX Control Module .....	1-40
Table 7.2:	LYNX Control Module LED Indicators .....	1-41
Table 7.3:	LYNX Control Module Connector P1 Pin Configuration .....	1-41
Table 7.4:	LYNX Control Module Connector P2 Pin Configuration .....	1-41
Table 7.5:	LYNX Control Module Connector P3 Pin Configuration .....	1-42
Table 7.6:	LYNX Control Module Configuration Switches .....	1-42
Table 7.7:	LYNX Control Module Group 20 I/O Pull-up Switches .....	1-42
Table 7.8:	LYNX Control Module Group 30 I/O Pull-up Switches .....	1-42
Table 8.1:	Power Requirements for the LYNX Control Module (Combination) .....	1-44
Table 8.2:	LYNX Control Module LED Indicators .....	1-45
Table 8.3:	LYNX Combination Control Module Connector P1 Pin Configuration .....	1-45
Table 8.4:	LYNX Combination Control Module Connector P2 Pin Configuration .....	1-45
Table 8.5:	LYNX Combination Control Module Connector P3 Pin Configuration .....	1-46
Table 8.6:	LYNX Combination Control Module Configuration Switches .....	1-46
Table 8.7:	LYNX Combination Control Module Group 20 I/O Pull-up Switches .....	1-46
Table 9.1:	Isolated Digital I/O Module P1 Connector Pin Configuration .....	1-48
Table 9.2:	Isolated I/O Module Group 40 I/O Pull-up Switches .....	1-49
Table 9.3:	Isolated I/O Module Group 50 I/O Pull-up Switches .....	1-49
Table 9.4:	Isolated I/O Module Input Specifications .....	1-49
Table 9.5:	Digital Filter Settings for the Isolated I/O .....	1-50
Table 9.6:	Digital Filter Settings for the Isolated I/O .....	1-50
Table 10.1:	High Speed Differential I/O Module Power Requirements .....	1-52
Table 10.2:	High Speed Differential I/O Module Pin Configuration .....	1-53
Table 10.3:	High Speed Differential I/O Module Input Specifications .....	1-53
Table 10.4:	Digital Filter Settings for the Differential I/O .....	1-54
Table 10.5:	LYNX Differential I/O Output Specifications .....	1-55

## List of Figures

Figure 1.1:	Basic Setup Configuration, RS-232 Interface .....	1-5
Figure 2.1:	Removing the End Plates .....	1-9
Figure 3.1:	Installing the DIN Rail Bracket .....	1-10
Figure 3.2:	Installing the LYNX System on a DIN Rail .....	1-11
Figure 3.3:	Removing the LYNX System from the DIN Rail .....	1-11
Figure 4.1:	Power Configuration. LYNX Control Module and external IMS Driver .....	1-13
Figure 4.2:	Stand-alone Power Configuration: 12-75VDC Supply .....	1-14
Figure 4.3:	Stand-alone Power Configuration: 5VDC .....	1-14
Figure 5.1:	Connecting the RS-232 Interface, Single Control Module System .....	1-17
Figure 5.2:	RS-232 Interface, Multiple Control Module System .....	1-19
Figure 5.3:	RS-485 Interface, Single Controller System .....	1-20
Figure 5.4:	RS-485 Interface, Multiple Control Module System .....	1-22
Figure 6.1:	Isolated I/O Applications .....	1-26
Figure 6.2:	Isolated I/O Input .....	1-28
Figure 6.3:	Isolated I/O Output .....	1-29
Figure 6.4:	Clock Functions .....	1-31
Figure 6.5:	IOS Variable Settings for the High Speed Differential I/O .....	1-32
Figure 6.6:	Differential I/O Input Equivalent Circuit .....	1-32
Figure 6.7:	Differential I/O Output Equivalent Circuit .....	1-33
Figure 6.8:	Connecting and Using an Encoder .....	1-35
Figure 6.9:	Half Axis Mode (Following) .....	1-37
Figure 6.10:	One and a Half Axis Operation .....	1-38
Figure 7.1:	LYNX Control Module Dimensions .....	1-39
Figure 7.2:	LYNX Control Module, Switches and Connections .....	1-40
Figure 8.1:	LYNX Control Module (Combination) Dimensions .....	1-43
Figure 8.2:	LYNX Control Module (Combination) Connections and Switches .....	1-44
Figure 9.1:	LYNX Isolated I/O Module Dimensions .....	1-47
Figure 9.2:	Isolated Digital I/O Module Connection Overview .....	1-48
Figure 9.3:	LYNX Isolated I/O Input Equivalent Circuit .....	1-49
Figure 9.4:	LYNX Isolated I/O Output Equivalent Circuit .....	1-50
Figure 10.1:	LYNX Differential I/O Module Dimensions .....	1-51
Figure 10.2:	High Speed Differential I/O Module Connection Overview .....	1-52
Figure 10.3:	LYNX Differential I/O Input Equivalent Circuit .....	1-54
Figure 10.4:	LYNX Differential I/O Output Equivalent Circuit .....	1-55

# Section 1

## Getting Started

### Section Overview

The purpose of this section is to get you up and running quickly. This section will help you do the following:

- Connect power to the LYNX Control Module.
- Connect and establish communications in single mode.
- Write a simple test program.

### Getting Started

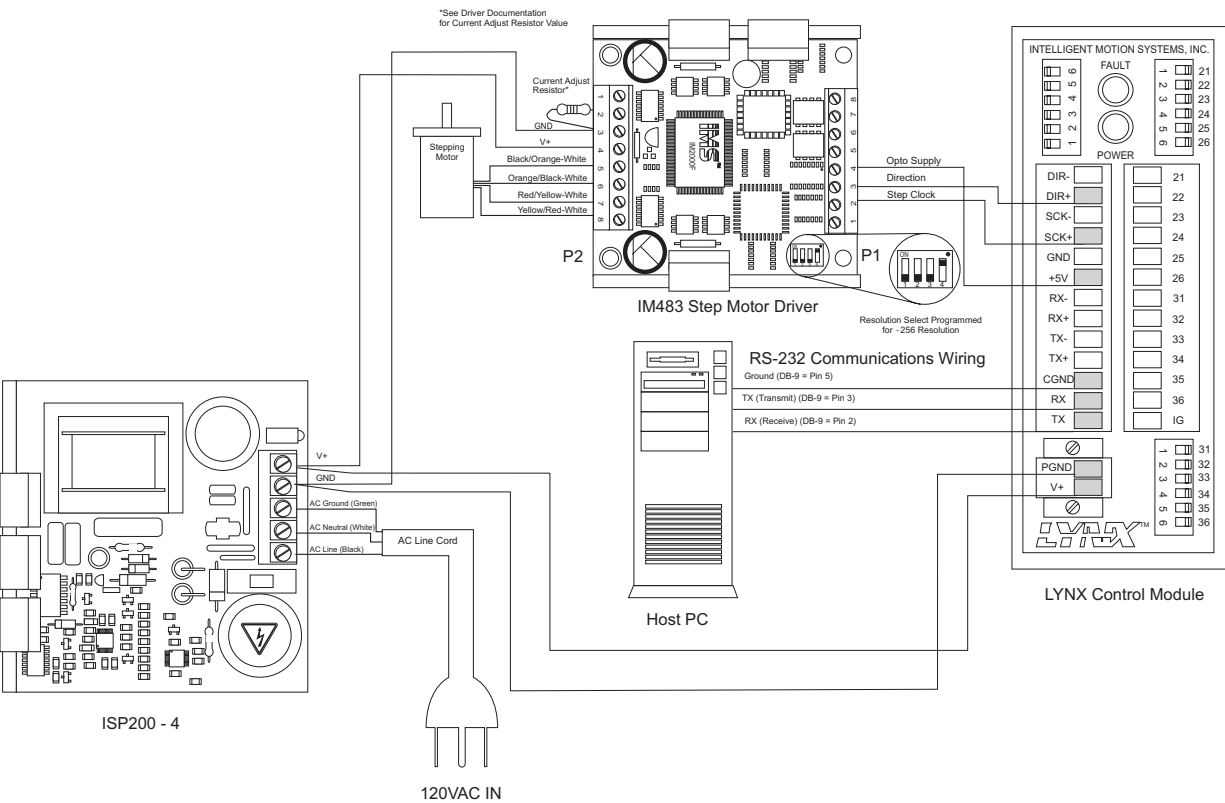

Figure 1.1: Basic Setup Configuration, RS-232 Interface

### Included in the Package

- (1) LYNX Control Module ..... (IMS P/N LX-CM100 or 200-000)
- (2) End Mounting Brackets ..... (IMS P/N LX-EB100-000)
- (1) IMS CD ..... (IMS P/N IMS-CD100-000)
- (1) Screw Driver ..... (IMS P/N SD1)

## *User Provided Tools and Equipment Needed*

- Serial Cable
- IM483 or equivalent step motor driver
- ISP200-4 or equivalent power supply
- M-22XX or equivalent stepping motor
- Wire Cutters/Strippers
- 22 gauge wire for logic level signals
- 18 gauge wire for power supply and motor wiring
- PC with a free serial port (COM 1 or 2)

## *Connecting the Power Supply*

1. Using the 18 gauge wire, connect the DC output of your power supply to V+ on your LYNX Control Module, and to P2, pin 4 on the IM483 Step Motor Driver. (Or V+ pin on equivalent driver.) *Figure 1.1.*
2. Connect the Power Supply Return (GND) to PGND on the LYNX Control Module, and to P2, pin 3 on the IM483 Step Motor Driver. (Or GND on equivalent driver.) *Figure 1.1.*
3. Connect the AC Line cord to your power supply in accordance with any user documentation accompanying the supply. **DO NOT PLUG IN AT THIS TIME!**

## *Connecting the Step Motor Driver*

1. Using 22 gauge wire, connect direction DIR+ on the LYNX Control Module to P1, pin 3 on the IM483 Driver. (Or direction pin of equivalent drive used.) *Figure 1.1.*
2. Connect Step Clock SCK+ of the LYNX Control Module to P1, pin 2 of the IM483 Driver. (Or Step Clock input of equivalent drive used.) *Figure 1.1.*
3. Connect the +5V output off the LYNX Control Module to the Opto Supply P1, pin 4 of the IM483 Driver. (Or Opto Supply of drive used if required.) *Figure 1.1.*
4. Set the Resolution Select DIP switch on the IM483 Driver to ÷256 resolution. *Figure 1.1.*

## *Motor Connections*

Connect the motor to the IM483 Step Motor Driver in accordance with *Figure 1.1.*

## *Communications Wiring*

Connect the Host PC to the LYNX Control Module (RS-232 Communications) in accordance with *Figure 1.1.* This is needed to program the LYNX Control Module.

## *Establishing Communications using the IMS Terminal*

Included in the LYNX shipping package is a CD with the IMS Terminal software. This is a programming/communications interface created by IMS to simplify the use of the LYNX. There is a 32 bit version for Windows 9x/NT4/2000 located on the CD. The IMS Terminal is also necessary to upgrade the software in your LYNX Control Module. These updates will be posted to the IMS website at <http://www.imshome.com/> as they are made available.

To install the IMS Terminal to your hard drive, insert the CD into your CD-ROM Drive. The CD should autostart to the IMS Main Index Page. If the CD does not autostart, click "Start > Run" and type "x:\IMS.exe" in the "Open" box and then click OK. **NOTE:** "x" is your CD ROM drive letter.

- 1) The IMS Main Index Page will be displayed.
- 2) Click the MicroLYNX icon in the upper right corner. This opens the LYNX Family Index Page.
- 3) Select IMS Terminal (Win9x) or IMS Terminal (WinNT).
- 4) Click SETUP in the Setup dialog box and follow the on-screen instructions.

Once the IMS Terminal is installed you may run the Setup.

- 1) Open the IMS Term by clicking Start>Programs>IMS Terminal>IMS Term.
- 2) Select or verify the Communications Port that you will be using with your LYNX.
  - a) Click in the Terminal Window to activate it.
  - b) Right click in the Terminal Window.
  - c) Click “Preferences” in the dialog box.
  - d) Click the “Comm Settings” tab at the top of the dialog box.
  - e) Under “Device” near the bottom of the box verify “LYNX” is selected. The BAUD rate is already set to the LYNX default. Do not change this setting until you have established communications with the LYNX Controller.
  - f) The “Window Size” settings are strictly optional. You may set these to whatever size is comfortable to you.
  - g) Click “OK”. The setting will be saved automatically.
- 3) Apply power to the LYNX Controller. The following sign-on message should appear in the Terminal window:

```
Program Copyright © 1996-2002 by:
Intelligent Motion Systems, Inc.
Marlborough, CT 06447
VER = xxxxxx   SER = Axxxxxx
```

NOTE: If the sign-on message does not appear, check the “Connected/Disconnected” tab at the bottom of the Terminal Window. If “Disconnected” is displayed, double click it to “Connect”.

Detailed instructions for the IMS Terminal software can be located in *Part III Software Reference* of this manual.

### *Testing the LYNX Setup*

Two basic instructions for communicating with a control module are SET and PRINT. The SET instruction is assumed and can be left off when communicating in ASCII mode. (You are in ASCII mode whenever you are using a text based terminal.) It is used to set variables and flags that define control module operation. The LYNX Software automatically recognizes the SET instruction whenever the name of the variable or flag is typed into the terminal. Here we will set the motor units variable (MUNIT) to 51200 by typing the following at the prompt (>):

```
MUNIT = 51200
```

The PRINT instruction is used to report the values of variables and flags. Now, double-check the value of MUNIT by typing the following at the prompt (>):

```
PRINT MUNIT
```

The return from your terminal should be 51200. Note that the case is not important for instructions, variables, and flags. They may be typed in upper or lower case.

Use the SLEW instruction to move the motor at a constant velocity. Be sure that the velocity provided is a reasonable value for your motor and drive and try to move the motor. For instance, at the prompt type:

```
SLEW 10
```

This will move the motor at a speed of 10 munits per second. If the motor does not move, verify that the wiring is in accordance with *Figure 1.1*. If a non IMS driver is being used, you may need to consult the user manual for that device.

Once you have been able to move the motor, the next step is to write a simple program to illustrate one of the dynamic features of the LYNX: the ability to convert motor steps to a dimension of linear or rotary distance. Let's begin by discussing the relationship between the MUNIT variable and user units. Typically when we perform a move we want to know the distance of that move in a familiar unit of measurement. That means translating motor steps to the desired unit of measurement. The LYNX Control Module has the capability of doing this for you. You have already set the motor units variable (MUNIT) to a value 51,200. With the driver set to a resolution of 256 micro-steps per step and a 1.8° step motor that will be equal to 1 revolution of the motor, or one USER UNIT. A user unit can be any unit of measure. At this point, by entering the instruction MOVR 1, the motor will turn one complete revolution relative to its current position. Therefore, 1 User Unit = 1 Motor Revolution. For the exercise below we will use degrees for our user unit. As the LYNX Product Manual indicates, the calculation required to select degrees as our user unit in this case is:

$$51200 \text{ Micro-steps per rev} \div 360 \text{ degrees} = 142.222 \text{ Micro-steps per degree}$$

By setting the MUNIT variable to 51200/360 the LYNX Control Module will perform the calculation to convert the user unit to degrees. Now, when issued, a relative motion instruction "MOVR 90" the motor will turn 90 degrees.

Now, enter a sample program that will convert motor steps to degrees, execute a 90° move, and report that move every 100 milliseconds while the motor is moving. Type the following bold commands:

```

`Enter Program Mode, start program at Location 2000.
PGM 2000
`Label the program TSTPGM.
LBL TSTPGM
` Set the user units to degrees.
MUNIT = 51200/360
` Set the max. velocity to 25 degrees per second.
VM = 25
` Execute a relative move of 90 degrees.
MOVR 90
` Report the position every 100 ms while moving.
LBL PRINTPOS
DELAY 100
PRINT "Axis position is", POS, "Degrees."
BR PRINTPOS, MVG
`End the program.
END
PGM

```

Now Type **TSTPGM** to run program.

This sample program will be stored starting at location 2000. It sets the conversion factor for the user units, sets the maximum velocity and then starts a motion. While the motion is occurring, the position is reported every 100 milliseconds.

At this point you may desire to restore the settings to their factory default as you may not wish to use degrees as your user unit. To do this, you will use the CP, DVF, and IP instructions.

**CP - Clear Program.**

To clear the program, type CP 1, 1. This will completely clear program memory space. Should you desire to only remove one program, the instruction "CP [Program Label]" i.e., "CP TSTPGM" would clear only that program. In this exercise only one program was entered, "CP TSTPGM" will clear it.

**DVF - Delete User Defined Variables and Flags.**

By entering DVF, all of the user defined variables will be removed. Although no Flags were set in this exercise, this command would clear them were they used.

**IP - Initialize Parameters**

This instruction will restore all of the parameters to their factory default state.

After entering these instructions a SAVE instruction should be entered.

# Section 2

## Connecting the LYNX System

### Section Overview

Each module of the LYNX System is a closed unit with a header of pins and locking tabs to connect it to another module in the system. Optional I/O modules are connected on the RIGHT side of the Control Module. This section covers:

- Removing the End Plates.
- Connecting/Disconnecting System Modules.

### Connecting the System

1. Remove the end plate(s) [A] from the Control Module. Depressing the locking clips [C] with a small screwdriver through the slot [B] on the top and bottom of the module and pulling them apart does this. See figure 2.1
2. Align the locking clips of the module being connected with the slots on the module being connected to.
3. Press modules firmly together, there will be an audible “snap” when the locking clips are fully engaged.
4. Reinstall the end plates at the ends of the LYNX System. They are designed to fit either end.
5. You are now ready to mount your LYNX System to a panel or DIN Rail using the optional hardware kit.

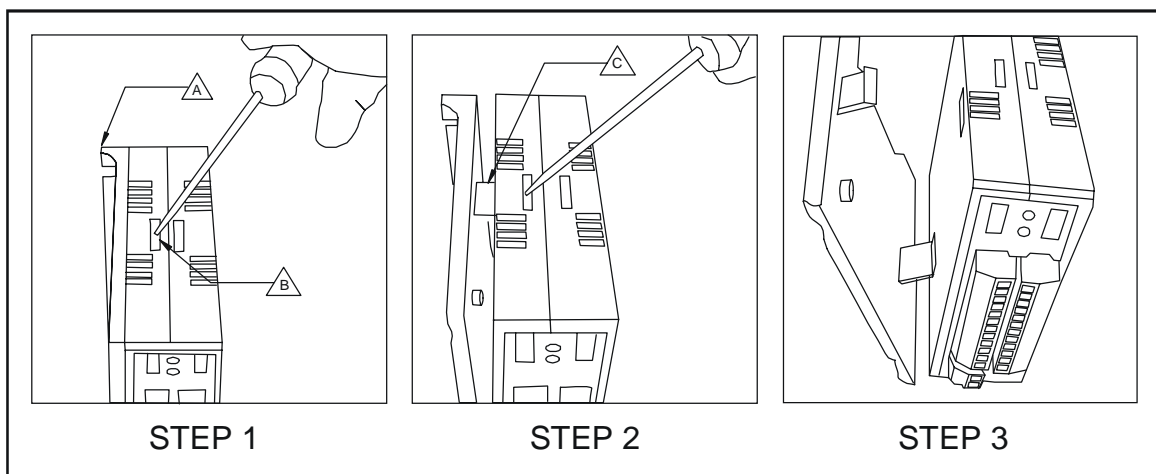

*Figure 2.1: Removing the End Plates*



**WARNING!** Exercise caution when removing end plates or separating LYNX System modules! Internal component damage may occur if the screwdriver is inserted too far into the slots!

# Section 3

## Mounting the LYNX System

### Section Overview

This section covers the two basic methods of mounting the LYNX System.

- Panel Mount.
- DIN Rail Mounting Option.

### Panel Mount

Using the panel mount option, the LYNX is designed to use #10 hardware (not included). Details such as screw length and threads are dependent on your overall system design.

### Din Rail Mounting Option

A DIN Rail mounting kit (IMS P/N LX-DB100-000) may be purchased as an option to your LYNX System. It includes all the hardware necessary to mount the system to either of the following recommended DIN rails:

TS35 X 7.5 or TS35 X 15

#### Included in the DIN Rail Mounting Kit

Included in the DIN Rail Mounting Kit is the following hardware:

- 2 - IMS0065 DIN Rail Brackets
- 4 - #6 Split Lock Washer
- 4 - #6-32X7/16 L Pan Hd Machine Screws
- 4 - #6 Flat Washer .040 Thick
- 2 - #6 X .250 L Set Screw
- 1 - Instruction Sheet

#### Mounting the LYNX System to a DIN Rail

In order to install your LYNX System on a DIN rail complete the following:

1. Insert the two DIN rail brackets into the slots located in the back of the system between the end plates and LYNX modules. The pull-tab on the DIN rail bracket must be on the bottom.
2. Using the #6 hardware provided, secure the bracket to the end plates. *Figure 3.1.* Tighten to 5 - 7 lb/in.

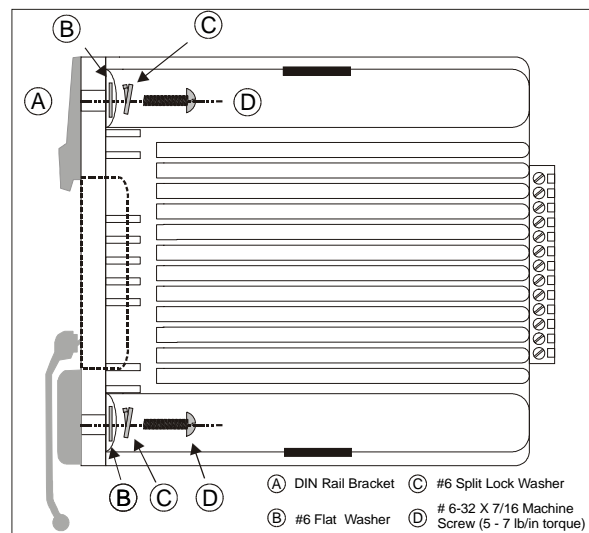
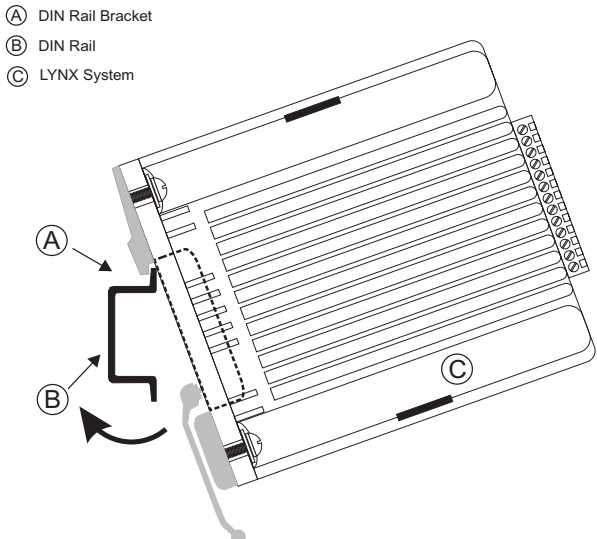

Figure 3.1: Installing the DIN Rail Bracket



3. Holding the LYNX System at an angle away from you, lower the upper slot of the DIN rail attachment onto the top edge of the DIN rail. Snap LYNX system into place. *Figure 3.2.*
4. Insert #6 X .250 L set screw (provided) into the TOP threaded insert located between the #6 screws on each end plate. *Figure 3.3.* Tighten until 12-14 in/oz. This will keep the system from sliding on the DIN rail.

**Figure 3.2: Installing the LYNX System on a DIN Rail**

To Remove the LYNX System from the DIN Rail:

1. Loosen the set screws located in the TOP threaded insert between the #6 screws on each end plate.
2. Grasp the pull-tabs located on the bottom of the DIN Rail brackets to release the LYNX system from the DIN Rail (*Figure 3.3 - C&D*) while gently lifting the front of the LYNX system.
3. Lift the LYNX System Away from the DIN Rail.

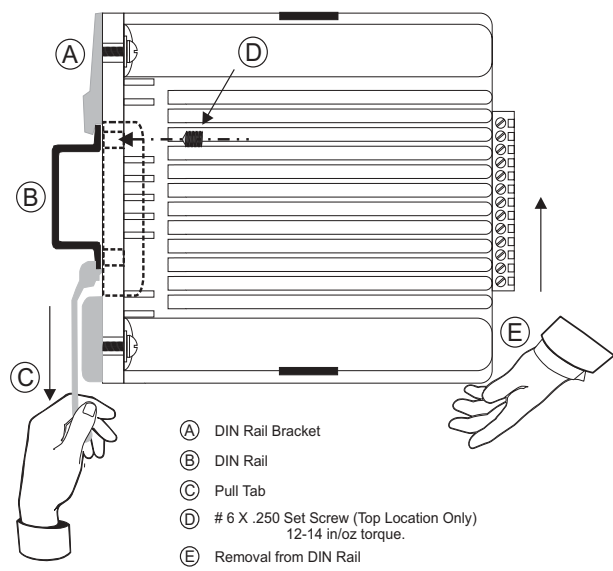

**Figure 3.3: Removing the LYNX System from the DIN Rail**

**N** **NOTE:** The DIN Rail Mounting option should only be used on STATIONARY Systems. It is not designed for transport!

# Section 4

---

## *Powering the LYNX System*

---

### Section Overview

This section covers the two basic power configurations for your LYNX System.

- Basic rules of wiring and shielding.
- LYNX Control Module with IMS Drivers.
- LYNX Control Module as Stand-alone or with Optional I/O Module.

---

### Wiring and Shielding

Noise is always present in a system that involves high power and small signal circuitry. Regardless of the power configuration that you use in your system, there are some wiring and shielding rules that you should follow to keep your noise-to-signal ratio as small as possible.

#### *Rules of Wiring*

- Power Supply and Motor wiring should be shielded twisted pairs run separately from signal carrying wires.
- A minimum of 1 twist per inch is recommended.
- Motors wiring should be shielded twisted pairs using 20-gauge wire, or 18 gauge or better for distance greater than 5 feet.
- Power ground return should be as short as possible to established ground.
- Power Supply wiring should be shielded twisted pairs. Use 18 Gauge wire if load is less than 4 amps, or 16 gauge for more than 4 amps.
- Do not “Daisy-Chain” power wiring to system components.

#### *Rules of Shielding*

- The shield must be tied to zero-signal reference potential. In order for shielding to be effective it is necessary for the signal to be earthed or grounded.
- Do not assume that earth ground is true earth ground. Depending on the distance to the main power cabinet it may be necessary to sink a ground rod at a critical location.
- The shield must be connected so that shield currents drain to signal-earth connections.
- The number of separate shields required in a system is equal to the number of independent signals being processed plus one for each power entrance.
- The shield should be tied to a single point to prevent ground loops.
- A second shield can be used over the primary shield, however the second shield is tied to ground at both ends.



**WARNING!** When using an unregulated supply, ensure that the output voltage does not exceed the maximum driver input voltage due to variations in line voltage! It is recommended that an input line filter be used on power supply to limit voltage spikes to the system!

# LYNX Control Module with IMS Driver

In this example, power is connected to the LYNX Control Module via connector P1. All optional plug-on modules are then powered from the LYNX Control Module. In this configuration, pins 5 and 6 on connector P2 of the Control Module become +5VDC (150mA, internally limited) regulated outputs. If an encoder is to be used in the system, it may be powered via these pins. Below is a table of recommended power supply specifications for each IMS drive.

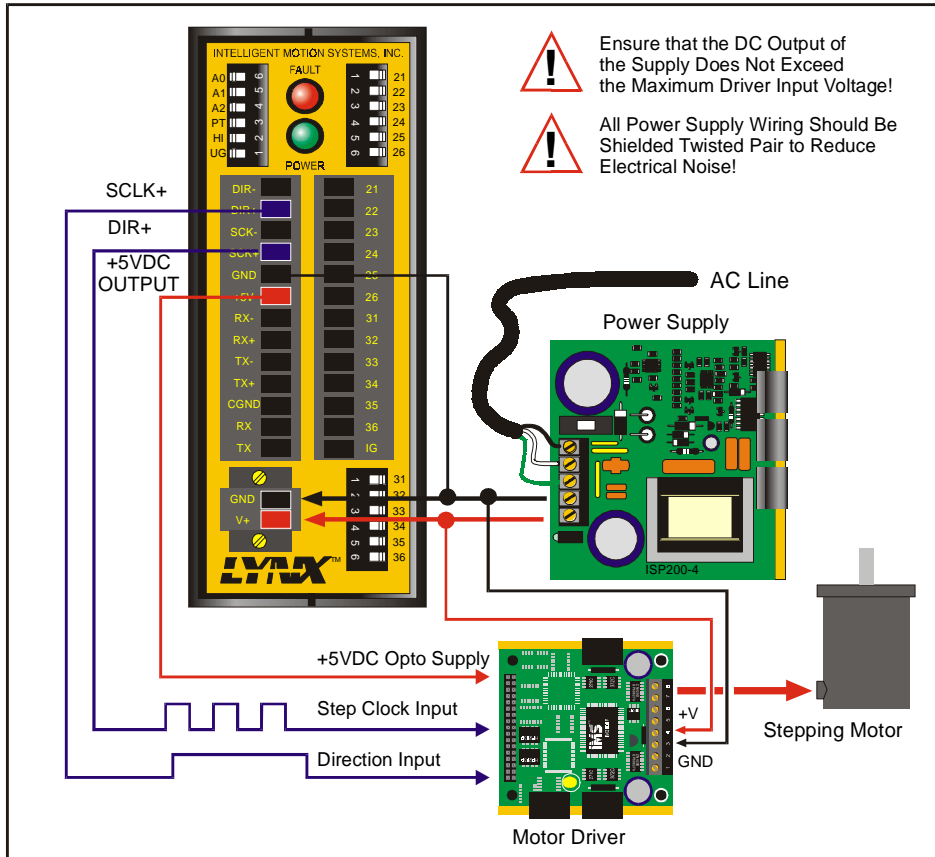

**Figure 4.1: Power Configuration. LYNX Control Module and external IMS Driver**

Power Supply Recommendations	
Recommended Type	Unregulated DC
Ripple Voltage	±10%
When Used With IM483/IM483H	
Output Voltage	+12 to +45VDC
*Output Current	2A (Typ.) 4A (Peak)
When Used With IM805/IM805H	
Output Voltage	+24 to +75VDC
*Output Current	4A (Typ.) 6A (Peak)

\*The output current needed is dependant on the supply voltage, motor selection and load.

# Stand-alone or with Optional I/O Modules

## +12 to +75VDC Supply

A +12 to +75VDC unregulated supply connected to P1 provides power to the LYNX Control Module and any optional I/O modules. As in the LYNX Controller with Driver (s) Configuration, pins 5 (Ground) and 6 (+5VDC) on connector P2 of the Control Module becomes a +5VDC (150mA, internally limited) regulated output.

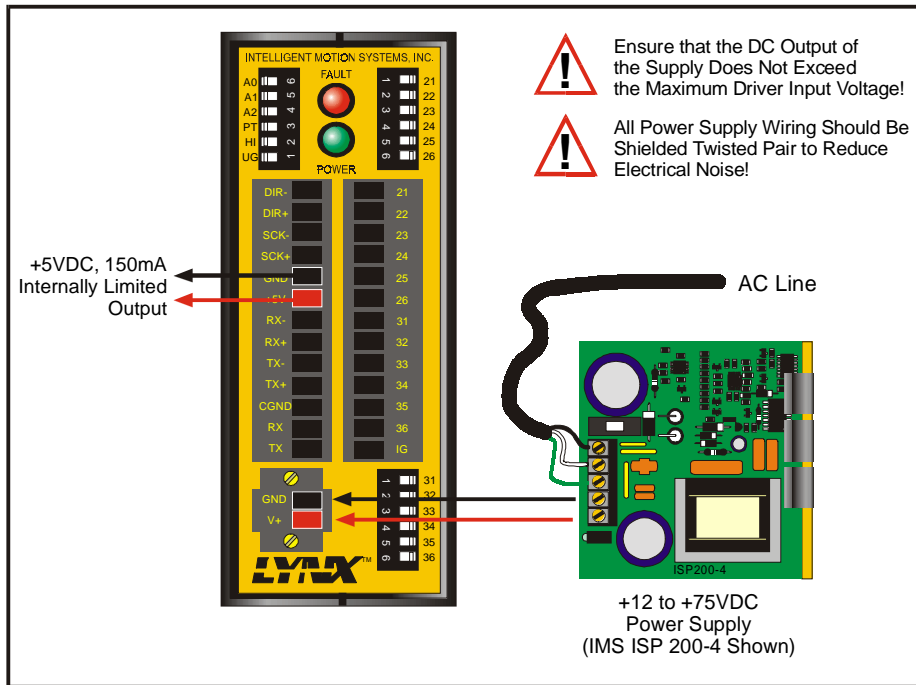

Figure 4.2: Stand-alone Power Configuration: 12 - 75 VDC Supply

## +5 VDC Supply

A +5VDC  $\pm 5\%$  regulated supply connected to pins 5 (Ground) and 6 (+5VDC) on connector P2 provides power to the LYNX Control Module and any optional I/O modules. Figure 4.3. It is assumed that external drives are being used and power is supplied to these drives separately. The LYNX Controller internally limits the current to 800mA. While the LYNX Controller and I/O Modules will only require 368mA, a fully configured LYNX System utilizing the outputs may require up to 800mA.

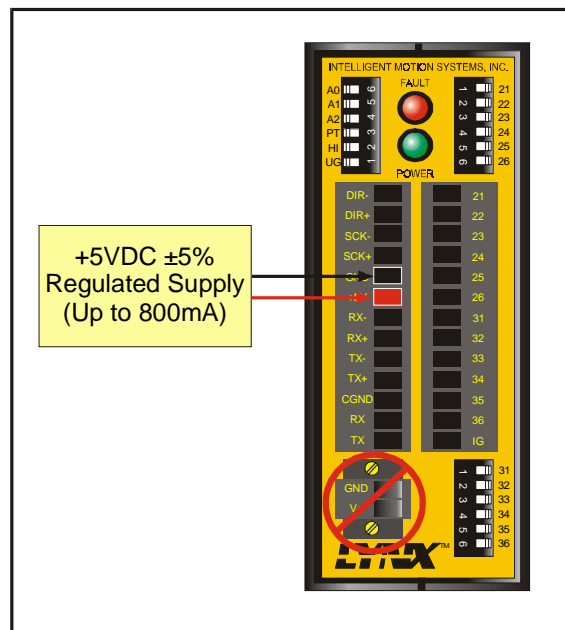

Figure 4.3: Stand-alone Power Configuration: 5 VDC

## Power Requirements

Power Requirements and Specifications	
Input Voltage	+12 to +75 VDC Unregulated or +5VDC $\pm$ 5%
Input Current	250mA (5VDC input) 165mA (+12VDC Input)* 95.0mA (+48 VDC Input)* 84.5mA (+75VDC Input)*  *I/O and +5VDC output unloaded (Control Module Only)
Output Voltage	+5VDC $\pm$ 5%
Output Current	150mA (Internally Limited)

Input Current Requirements per Module	
LYNX Control Module	250 mA (+5VDC Input)
Isolated Digital I/O Module	68mA (5VDC Input)
Differential I/O Module	50mA (+5VDC Input)
Output Current	150mA (Internally Limited)

**Table 4.1: Power Requirements**



**WARNING!** When using an unregulated supply, ensure that the output voltage does not exceed the maximum driver input voltage due to variations in line voltage! It is recommended that an input line filter be used on power supply to limit voltage spikes to the system!



**WARNING!** When specifying the input voltage of the LYNX System ensure that the power supply output voltage corresponds with the input voltage of the driver used!



**WARNING!** When specifying an external power supply ensure that all modules are included in the power calculation!



**WARNING!** Only one of these methods of Powering the LYNX System can be used!

# Section 5

## *The Communications Interface*

### Section Overview

The LYNX Control Module features two communication interfaces: [RS-232](#) and [RS-485](#). For both channels, the [BAUD](#) rate is software configured, using the [BAUD](#) variable, to 4800, 9600, 19200 or 38400 bits/sec. The factory default is set to 19200 bits/sec. Default data settings are 8 data bits, 1 stop bit and no parity.

A host computer can be connected to either interface to provide commands to the control module or to multiple control modules in a system. Since most personal computers are equipped with an RS-232 serial port, it is most common to use the RS-232 interface for communications from the host computer to the control module. You will typically want to use this interface option if your Host PC will be within 50 feet of your system. Should your system design place the LYNX Control Module at a distance greater than 50 feet, it will be necessary for you to use the RS-485 interface option. You can accomplish this by using either an RS-232 to RS-485 converter, such as the converter sold by IMS (Part # CV-3222), or installing an RS-485 board in an open slot in your host PC.

Covered in detail in this section are:

- RS-232 Interface, Single Control Module System.
- RS-232 Interface, Multiple Controller System.
- RS-485 Interface, Single Control Module Interface.
- RS-485 interface, Multiple Controller System.
- Communicating with the LYNX System using Windows95/98 HyperTerminal.
- Communicating with the LYNX System using the IMS Terminal software.
- LYNX Control Module Modes of Operation.
- LYNX Control Module Communication Modes.

### Connecting the RS-232 Interface

#### *Single Control Module System*

In systems with a single control module, also referred to as Single Mode, the LYNX Control Module is connected directly to a free serial port of the Host PC. Wiring and connection should be performed in accordance with the following table and diagram. In this mode the PARTY switch will be in the OFF position, and the PARTY Flag will be set to 0 in software. This is the factory default setting. Please be aware that you cannot communicate with the LYNX Control Module in single mode unless those conditions exist.



**WARNING!** Failure to connect communications ground as shown may result in damage to the Control Module and/or Host!



**NOTE:** If using the RS-232 Interface Option, the Host PC MUST be less than 50 feet from the Control Module. If your system will be greater than 50 feet from the Host PC you must use the RS-485/RS485 Interface.

RS-232 Interface: Wiring And Connections					
LYNX Control Module		25 Pin Serial Port on PC		9 Pin Serial Port on PC	
Receive Data (RX)	Pin 12	Transmit Data (TX)	Pin 2	Transmit Data (TX)	Pin 3
Transmit Data (TX)	Pin 13	Receive Data (RX)	Pin 3	Receive Data (RX)	Pin 2
Communications Ground	Pin 11	Communications Ground	Pin 7	Communications Ground	Pin 5

**Table 5.1: Wiring Connections: RS-232 Interface Single Control Module System**

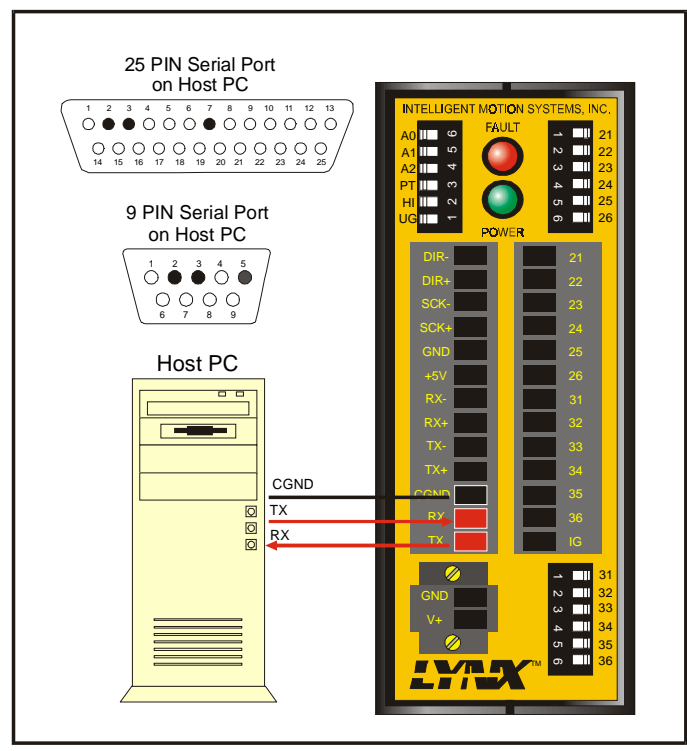

**Figure 5.1: Connecting the RS-232 Interface, Single Control Module System**

### Multiple Control Module System

When connecting multiple control modules in a system using the RS-232 interface, it is necessary to establish one control module as the **HOST**. This control module will be connected to the Host PC exactly as the system using a single control module. The system **HOST** is established by one of two methods, by manually selecting the Host switch (configuration switch #2, labeled HI) to the ON position, or by setting the **HOST Flag** to True (1) in software. The remaining control modules in the system must then be connected to the **HOST** control module using the RS-485 interface and will have their **Host switch** set to OFF (HOST Flag = 0).

In this interface configuration, Host PC communications will be received by the Host Control Module via RS-232 and forwarded to all of the other control modules in the system via the RS-485 channel. Responses from the individual control modules in the system will be routed back to the Host Control Module via the RS-485 channel, then internally converted to RS-232 before being forwarded back to the Host PC.

In systems with multiple controllers it is necessary to communicate with the control modules using **PARTY** Mode of operation. The LYNX Control Modules in the system are configured for this mode of operation by setting the **Party Switch** (configuration switch #3, labeled PT) to the ON position, or setting the **PARTY Flag** to True (1), in software. It is necessary for all of the controllers in a system to have this configuration selected. When operating in **PARTY** Mode each control module in the system will need a unique address, or

name, to identify it in the system. This can be done using configuration switches A0-A2, or by using the software command SET [DN](#). For example, to set the name of a controller to "A" you would use the following command: SET DN = "A". The factory default name is "!". To set the address of the controller using the configuration switches use the following table:

Party Mode Address Configuration Switches			
Address	A2	A1	A0
None	OFF	OFF	OFF
A	OFF	OFF	ON
B	OFF	ON	OFF
C	OFF	ON	ON
D	ON	OFF	OFF
E	ON	OFF	ON
F	ON	ON	OFF
G	ON	ON	ON

**Table 5.2: Party Mode Address Configuration Switch Settings**

In setting up your system for [PARTY](#) operation the most practical approach would be to observe the following steps:

1. Connect the Host Control Module to the Host PC configured for single mode operation.
2. Establish communications with the [HOST](#) Control Module. (For help in doing this see Software Reference: [Using the LYNX Terminal](#).) Using the Command: SET DN or the configuration switches, give the controller a unique name. If using the software command this can be any upper or lower case ASCII character or number 0-9. Save the name using the command [SAVE](#).
3. Set the appropriate [HOST](#) and [PARTY](#) configuration in accordance with the table and diagram below. Remove power.
4. Connect the next control module in the system in accordance with the following table and diagram, setting the [PARTY](#) switch in the ON position. If you desire you can set the PARTY Flag to "1" in software later and turn the switch off.
5. Establish communications with this module using the factory default name "!". This name cannot be reused. Rename and save the new name. Remove power.
6. Repeat the last two steps for each additional control module in the system.



**WARNING!** Failure to connect communications ground as shown may result in damage to the Control Module and/or Host!



**NOTE:** If using the RS-232 Interface Option, the Host PC MUST be less than 50 feet from the Control Module. If your system will be greater than 50 feet from the Host PC you must use the RS-485/RS485 Interface.

RS-232 Interface: Wiring And Connections for Multiple LYNX Nodes					
Host Control Module		Control Module #1		Control Module #n	
Receive Data (RX-)	Pin 7	Transmit Data (TX-)	Pin 9	Transmit Data (TX-)	Pin 9
Receive Data (RX+)	Pin 8	Transmit Data (TX+)	Pin 10	Transmit Data (TX+)	Pin 10
Transmit Data (TX-)	Pin 9	Receive Data (RX-)	Pin 7	Receive Data (RX-)	Pin 7
Transmit Data (TX+)	Pin 10	Receive Data (RX+)	Pin 8	Receive Data (RX+)	Pin 8
Communications Ground	Pin 11	Communications Ground	Pin 11	Communications Ground	Pin 11
HOST Switch = ON or HOST Flag = TRUE (1)		HOST Switch = OFF or HOST Flag = FALSE (0)		HOST Switch = OFF or HOST Flag = FALSE (0)	
PARTY Switch = ON or PARTY Flag = TRUE (1)		PARTY Switch = ON or PARTY Flag = TRUE (1)		PARTY Switch = ON or PARTY Flag = TRUE (1)	

**Table 5.3: Connections and Settings Multiple Control Module System, RS-232 Interface**

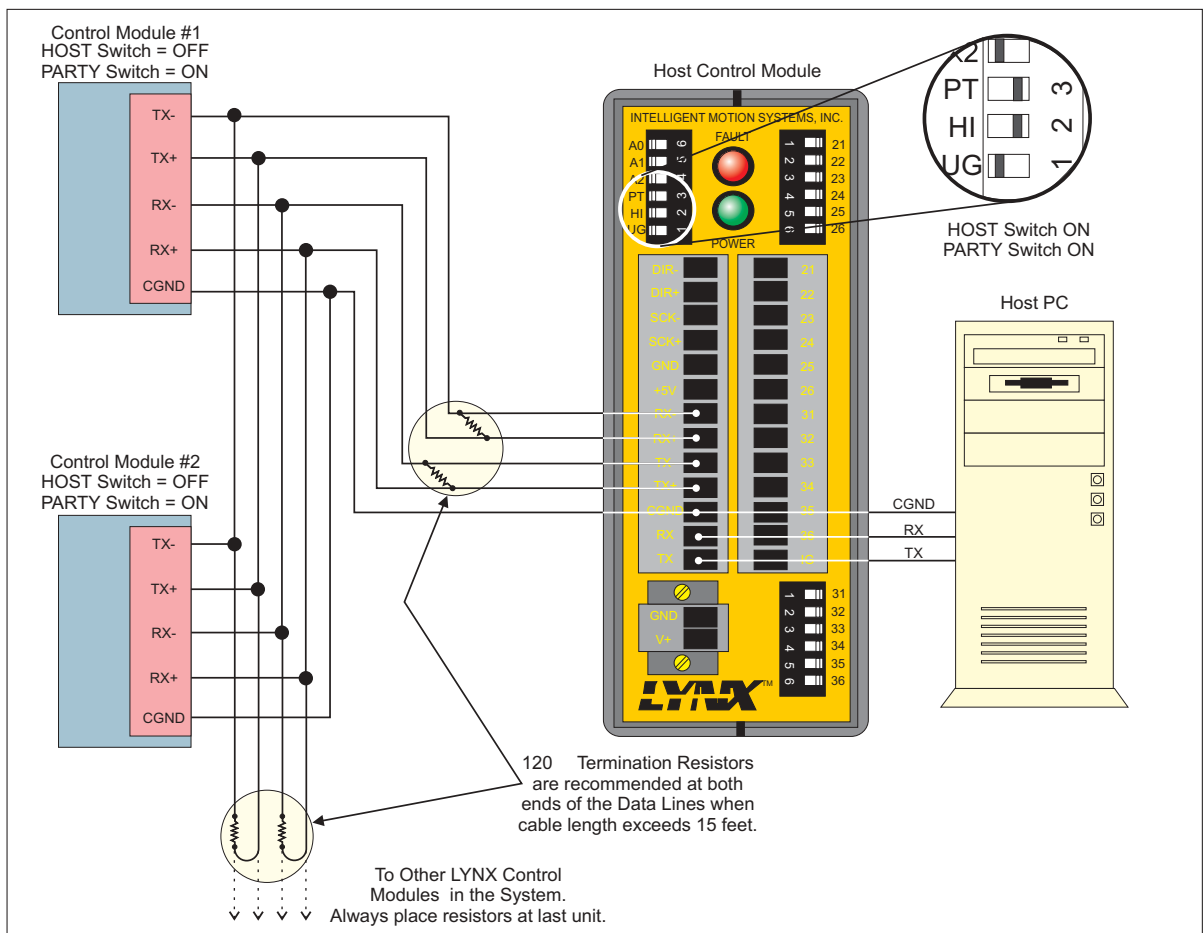

**Figure 5.2: RS-232 Interface, Multiple Control Module System**

### Data Cable Termination Resistors

Data Cable lengths greater than 15 feet (4.5 meters) are susceptible to signal reflection and/or noise. IMS recommends 120Ω termination resistors at both ends of the Data Cables. An example of resistor placement is shown in Figure 5.2. For systems with Data Cables 15 feet (4.5 meters) or less, the termination resistors are generally not required. For more information and other RS-232 termination techniques, search the Internet for "RS-232 Application Notes".

# Connecting the RS-485 Interface

## Single Controller System

In a Single Controller System, the RS-485 interface option would be used if the Control Module is located at a distance greater than 50 feet from the Host PC. Since most PC's do not come with an RS-485 board pre-installed, you will have to install an RS-485 board in an open slot in your PC, or purchase an RS-232 to RS-485 converter, such as the CV-3222 sold by IMS, to use this connection interface. For wiring and connection information please use the following table and diagram:

RS-485 Board or RS232 to RS-485 Converter	LYNX Controller Module	
Receive Data (RX-)	Transmit Data (TX-)	Pin 9
Receive Data (RX+)	Transmit Data (TX+)	Pin 10
Transmit Data (TX-)	Receive Data (RX-)	Pin 7
Transmit Data (TX+)	Receive Data (RX+)	Pin 8
Communications Ground	Communications Ground	Pin 11

Table 5.4: RS-485 Interface Connections

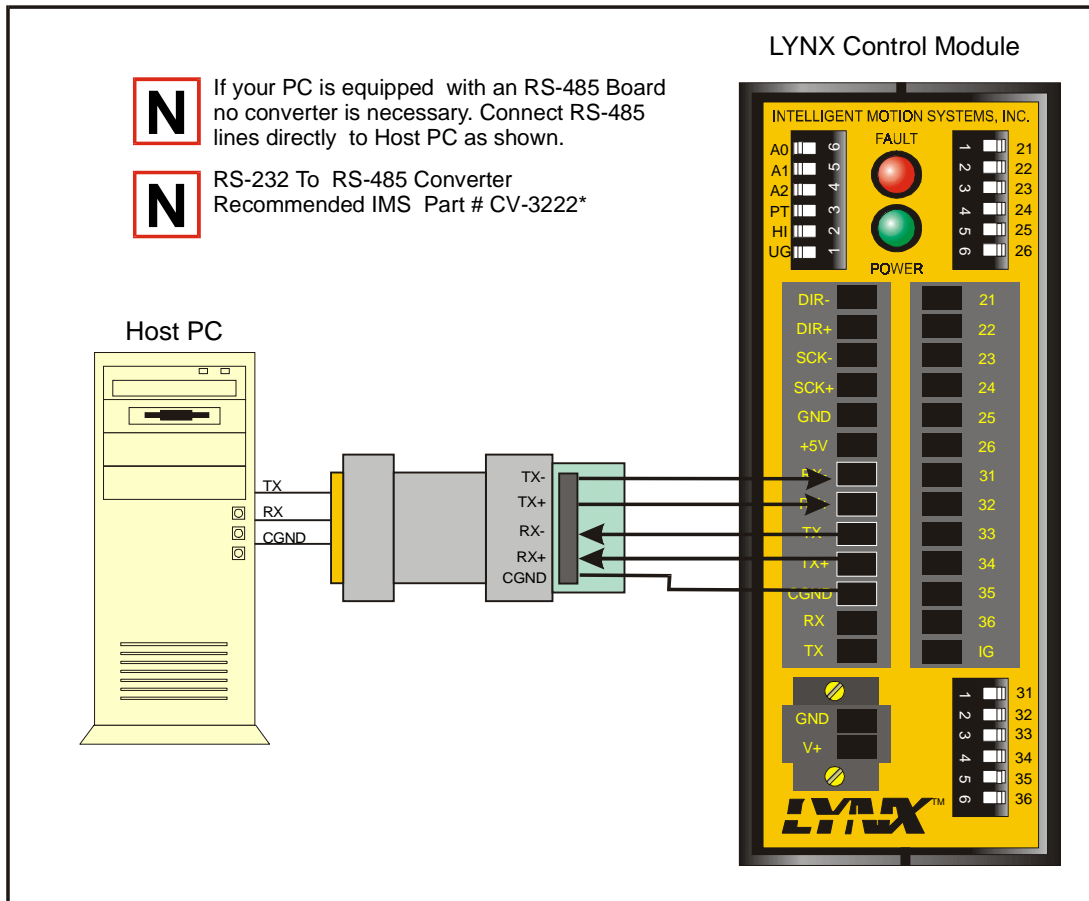

Figure 5.3: RS-485 Interface, Single Controller System

**N** **NOTE:** The HOST switch MUST be off to communicate with the Control Module in a Single Controller System using the RS-485 Interface.

### Multiple Controller System

When using the RS-485 interface in a Multiple Controller System, the Host PC as well as all of the control modules communicate on the RS-485 interface. In this case, there is no Host Interface Control Module, so all control modules in the system should have their Host switch OFF or HOST flag set to False (0). The Host PC will be equipped with an RS-485 board or RS-232 to 485 converter. In systems with multiple controllers it is necessary to communicate with the control modules using PARTY Mode of operation. The LYNX

Party Mode Address Configuration Switches			
Address	A2	A1	A0
None	OFF	OFF	OFF
A	OFF	OFF	ON
B	OFF	ON	OFF
C	OFF	ON	ON
D	ON	OFF	OFF
E	ON	OFF	ON
F	ON	ON	OFF
G	ON	ON	ON

*Table 5.5: Party Mode Address Configuration Switch Settings*

Control modules in the system are configured for this mode of operation by setting the Party Switch (configuration switch #3, labeled PT) to the ON position or setting the PARTY Flag to True (1), in software. It is necessary for all of the controllers in a system to have this configuration selected. When operating in PARTY Mode each control module in the system will need a unique address, or name, to identify it in the system. This can be done using configuration switches A0-A2, or by using the software command SET DN. For example, to set the name of a controller to “A” you would use the following command: SET DN = “A”. The factory default name is “!”. To set the address of the controller using the configuration switches use the above table.

In setting up your system for PARTY operation the most practical approach would be to observe the following steps:

1. Connect the Host Control Module to the Host PC configured for Single Mode Operation.
2. Establish communications with the HOST Control Module. Using the Command: SET DN or the configuration switches, give the controller a unique name. If using the software command this can be any upper or lower case ASCII character or number 0-9. Save the name using the command SAVE.
3. Set the appropriate HOST and PARTY configuration in accordance with the following table and diagram. Remove power.
4. Connect the next control module in the system in accordance with the following table and diagram, setting the PARTY switch in the ON position. If you desire you can set the PARTY Flag to “1” in software later and turn the switch off.
5. Establish communications with this module using the factory default name “!”. This name cannot be reused. Rename and save the new name. Remove power.
6. Repeat the last two steps for each additional control module in the system.

RS-485 Interface: Wiring And Connections for Multiple LYNX Nodes				
RS-232 to RS-485 Converter	Control Module #1		Control Module #n	
Receive Data (RX-)	Transmit Data (TX-)	Pin 9	Transmit Data (TX-)	Pin 9
Receive Data (RX+)	Transmit Data (TX+)	Pin 10	Transmit Data (TX+)	Pin 10
Transmit Data (TX-)	Receive Data (RX-)	Pin 7	Receive Data (RX-)	Pin 7
Transmit Data (TX+)	Receive Data (RX+)	Pin 8	Receive Data (RX+)	Pin 8
Communications Ground	Communications Ground	Pin 11	Communications Ground	Pin 11
	HOST Switch = OFF or HOST Flag = FALSE (0)		HOST Switch = OFF or HOST Flag = FALSE (0)	
	PARTY Switch = ON or PARTY Flag = TRUE (1)		PARTY Switch = ON or PARTY Flag = TRUE (1)	

**Table 5.6: RS-485 Interface Connections and Settings, Multiple Control Module System**

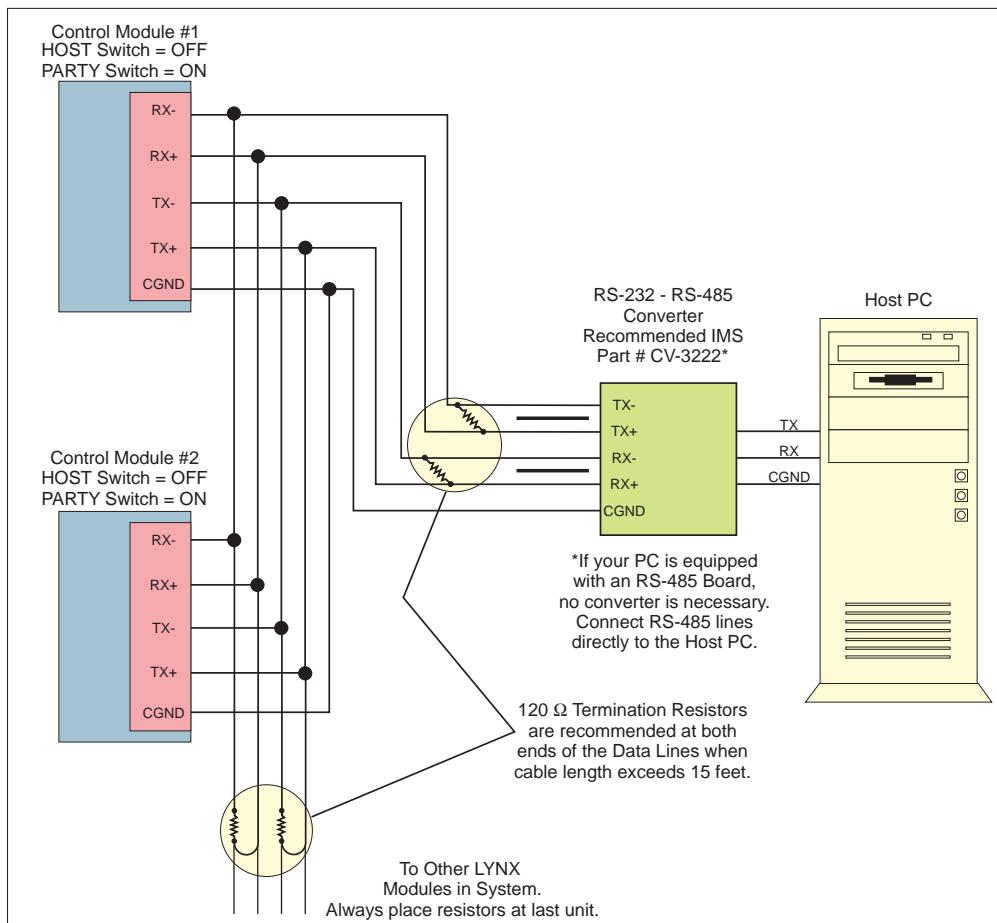

**Figure 5.4: RS-485 Interface, Multiple Control Module System**

It is also possible to communicate with a controller in the system in single mode by sending it a command (with address) to clear the party flag and then communicate with it as in single mode (no line feed terminator) then reset the [PARTY](#) Flag when done.

### Data Cable Termination Resistors

Data Cable lengths greater than 15 feet (4.5 meters) are susceptible to signal reflection and/or noise. IMS recommends 120 $\Omega$  termination resistors at both ends of the Data Cables. An example of resistor placement is shown in Figure 5.4. For systems with Data Cables 15 feet (4.5 meters) or less, the termination resistors are generally not required. For more information and other RS-485 termination techniques, search the Internet for "RS-485 Application Notes".

---

## LYNX Control Module Modes of Operation

There are three modes of operation for the LYNX control module. These are Immediate Mode, Program Mode, and EXEC Mode.

### *Immediate Mode*

In this mode, the control module responds to instructions from the user that may be a result of the user typing instructions directly into a host terminal, or of a user program running on the host which communicates with the control module.

### *Program Mode*

The second mode of operation of the control module is Program Mode. All user programs are written in this mode. Unlike the other modes of operation, no commands or instructions can be issued to the control module in Immediate Mode. This mode is exclusively for writing programs for the controller. The command to enter Program Mode is PGM <address>. When starting Program Mode, you must specify at what address to enter the program instructions in the program space. Simply type PGM again when you have finished entering your program commands to go back to Immediate Mode.

### *EXEC Mode*

In EXEC Mode a program is executed either in response to the EXEC instruction from the user in Immediate Mode, or in response to a specified input. While the control module is running a program, the user may still communicate with it in Immediate Mode. As part of a user program, the control module may start a second task using the RUN instruction. Thus, there can be two tasks running on the control module at the same time, a foreground task (started by the EXEC instruction in Immediate Mode) and a background task (started by the RUN instruction in Program Mode).

---

## LYNX Control Module Communication Modes

When the control module is operating in Immediate Mode, there are two methods of communicating. The first is ASCII where the instructions are communicated to the control module in the form of ASCII mnemonics and data is also given in ASCII format. The second is binary where the instruction is in the form of an OpCode and numeric data is given in IEEE floating point hex format. In binary mode, there is also the option of including a checksum to ensure that information is received properly at the control module. The **BIO** flag controls the method of communication. When it is True (1) the binary method should be used, and when it is False (0) the ASCII method should be used.

### *ASCII*

ASCII is the most common mode of communicating with the LYNX System. It allows the use of readily available terminal programs such as HyperTerminal, ProComm, and the new IMS Terminal.

When using the ASCII method of communications, the control module tests for four special characters each time a character is received. These characters are given in the table below along with an explanation of what occurs when the character is received.

The command format in ASCII mode when the control module is in Single Mode (PARTY = FALSE) is:

```
<Mnemonic><white space><ASCII data for 1st parameter>, <ASCII data for 2nd parameter>, ... , <ASCII data for nth parameter><CR/LF>
```

The mnemonics for Control Module instructions, variables, flags and keywords are given in *Part III Software Reference* of this manual. White space is at least one space or tab character. CR/LF represent the

ASCII Mode Special Command Characters	
Character	Action at MicroLYNX
<esc> Escape Key	Terminates all active operations and all running programs.
<^C> Ctrl+C Keys	Terminates all active operations and all running programs, forces a reset of the MicroLYNX.
<BKSP> Backspace Key	Moves the cursor back one in the buffer to correct a typing error.
<CR> or <LF> Carriage Return or Line Feed	Depending on the mode, either Single or Party. <LF> is not necessary in Single Mode communications. <CTRL+J> is the same as <LF> (0A Hex)

**Table 5.7: ASCII Mode Special Command Characters**

carriage return line feed characters that are transmitted in response to the Enter key on the keyboard provided the ASCII setup specifies “Send line feeds with line ends”. Note that there need not be a space between the data for the last parameter and the CR/LF. Also note that if there is only one parameter, the CR/LF would immediately follow the data for that parameter.

The command format in ASCII mode when the control module is in Party Mode (PARTY = TRUE) would be identical to that in Single Mode with the exception that the entire command would be preceded by the control module’s address character (stored in DN) and terminated by a CTRL-J rather than ENTER:

<Address character><Mnemonic><white space><ASCII data for 1<sup>st</sup> parameter>, <ASCII data for 2<sup>nd</sup> parameter>, ... , <ASCII data for n<sup>th</sup> parameter><CTRL-J>

## Binary

Binary mode communications is faster than ASCII and would most likely be used in a system design where the communication speed is critical to system operation. This mode cannot be used with standard terminal software.

The command format in binary mode when the control module is in Single Mode (PARTY = FALSE) is:

<20H><character count><opcode><Field type for 1<sup>st</sup> parameter><IEEE hex data for 1<sup>st</sup> parameter><0EH><Field type for 2<sup>nd</sup> parameter><IEEE hex data for 2<sup>nd</sup> parameter><0EH> ... <Field type for n<sup>th</sup> parameter><IEEE hex data for n<sup>th</sup> parameter><optional checksum>

Note that <20H> is 20 hex, the character count is the number of characters to follow the character count not including the checksum if one is being used. The OpCodes for control module instructions, variables, flags and keywords are given in Sections 15 and 16 of this document. The Field type byte will be one of the following based on the type of data that is expected for the specific parameter:

<0EH> is 0E hex, which is a separator character in this mode. Finally, the optional checksum will be included if CSE is TRUE and excluded if it is FALSE. If included, the checksum is the low eight bits of the complemented sixteen-bit sum of the address field (20H here), character count, OpCode, all data fields and separators (0E hex).

Binary Hex Codes	
Hex Code	Data Type
01	Label Text
02	ASCII Text
03	1 byte unsigned
04	2 byte signed
05	2 byte unsigned
06	4 byte signed
07	4 byte unsigned
08	4 byte float

**Table 5.8: Binary Hex Codes**

# Section 6

## *Configuring the Digital I/O*

### Section Overview

This section covers the usage of the Isolated Digital and High Speed Differential I/O Modules which are available on the LYNX System.

- System I/O Availability by Module.
- The Isolated Digital I/O:
  - Configuring an Input
  - Setting the Digital Input Filtering for the Isolated I/O
  - Configuring an Output
  - Setting the Binary State of an I/O Group
- The Differential I/O:
  - The Clock Interface
  - Configuring an Input
  - Setting the Digital Input Filtering for the Differential I/O
  - Configuring an Output.
- Typical Functions of the Differential I/O.

### System I/O Availability by Module

The LYNX System offers designers the ability to custom-tailor the LYNX System for their individual application needs. Below is a table illustrating the available configurations and the I/O set which would be present with each configuration.

Allowable LYNX System I/O Configurations							
LYNX System	LX-CM100	LX-CM200	LX-CM100 LX-DI100	LX-CM200 LX-DI100	LX-CM100 LX-DD100	LX-CM100 LX-DI100 LX-DD100	LX-CM100 LX-DC100
GROUP 10 HIGH SPEED	11 & 12	11, 12, 13, 14 & 17	11 & 12	11, 12, 13, 14 & 17	11 - 18	11 - 18	11, 12, 13, 14 & 17
GROUP 20 ISOLATED	21 - 26	21 - 26	21 - 26	21 - 26	21 - 26	21 - 26	21 - 26
GROUP 30 ISOLATED	31 - 36	N/A	31 - 36	N/A	31 - 36	31 - 36	31 - 36
GROUP 40 ISOLATED	N/A	N/A	41 - 46	41 - 46	N/A	41 - 46	41 - 46
GROUP 50 ISOLATED	N/A	N/A	51 - 56	51 - 56	N/A	51 - 56	N/A

*Table 6.1: System I/O Availability by Module*

---

# The Isolated Digital I/O

The LYNX CM100 Control Module has a standard set of twelve +5 to +24VDC I/O lines and the LYNX CM200 Combination Control Module has a standard set of six +5 to +24VDC I/O lines. These I/O lines may be programmed individually as either general purpose or dedicated inputs or outputs, or collectively as a group. The Isolated Digital I/O may be expanded to a maximum of twenty-four (24) lines on the CM100 and a maximum of eighteen (18) lines on the CM200.

The I/O groups and lines are numbered in the following fashion:

- Group 20 = Lines 21 - 26 (Standard CM100 and CM200)
- Group 30 = Lines 31 - 36 (Standard CM100 only)
- Group 40 = Lines 41 - 46 (Optional CM100 and CM200)
- Group 50 = Lines 51 - 56 (Optional CM100 and CM200)

The isolated digital I/O may be defined as either active HIGH or active LOW. When the I/O is configured as active HIGH, the level is +5 to +24 VDC and the state will be read as a “1”. If the level is 0 VDC then the state will be read as “0”. Inversely if configured as active LOW, then the state of the I/O will be read as a “1” when the level is LOW, and a “0” when the level is HIGH. The active HIGH/LOW state is configured by the third parameter of the IOS variable, which is explained further on. The goal of this I/O configuration scheme is to maximize compatibility between the LYNX and standard sensors and switches. The LYNX I/O scheme is a powerful tool for machine and process control. Because of this power, a level of complexity in setup and use is found that doesn’t exist in controllers with a less capable I/O set.

## *Uses of the Isolated Digital I/O*

The isolated I/O may be utilized to receive input from external devices such as sensors, switches or PLC outputs. When configured as outputs, devices such as relays, solenoids, LED’s and PLC inputs may be controlled from the LYNX. Depending on the device connected, the input or output may be pulled-up to either the internal +5VDC supply or an external +5 to +24VDC supply, or the I/O lines may be pulled-down to ground. These features, combined with the programmability and robust construction of the LYNX I/O open an endless vista of possible uses for the I/O in your application.

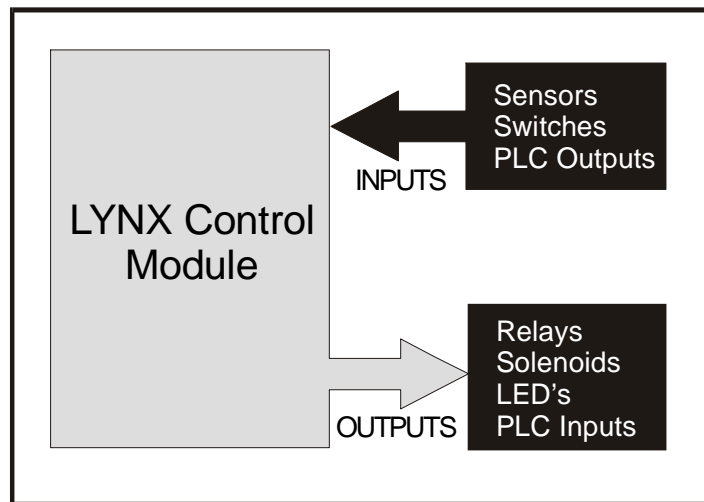

**Figure 6.1: Isolated I/O Applications**

Each I/O line may be individually programmed to any one of 8 dedicated input functions, 7 dedicated output functions, or as general purpose inputs or outputs. The I/O may be addressed individually, or as a group. The active state of the line or group may also be set. All of these possible functions are accomplished with of the IOS variable.

### The IOS Variable

The IOS variable has three parameters when used to configure the isolated digital I/O. These are:

- 1] **I/O Line Type:** Specifies the the type of I/O that the line or group will be configured as, i.e. general purpose or dedicated function.
- 2] **I/O Line Function:** Either an input or an output.
- 3] **Active State:** Specifies whether or not the line will be active HIGH or active LOW.

The default configuration of the standard I/O set is: 0,0,1. This means that by default each line in group 20 is configured to be a General Purpose (0), Input (0), which is active when HIGH (1). The following figure and exercises illustrate possible configurations of the IOS.

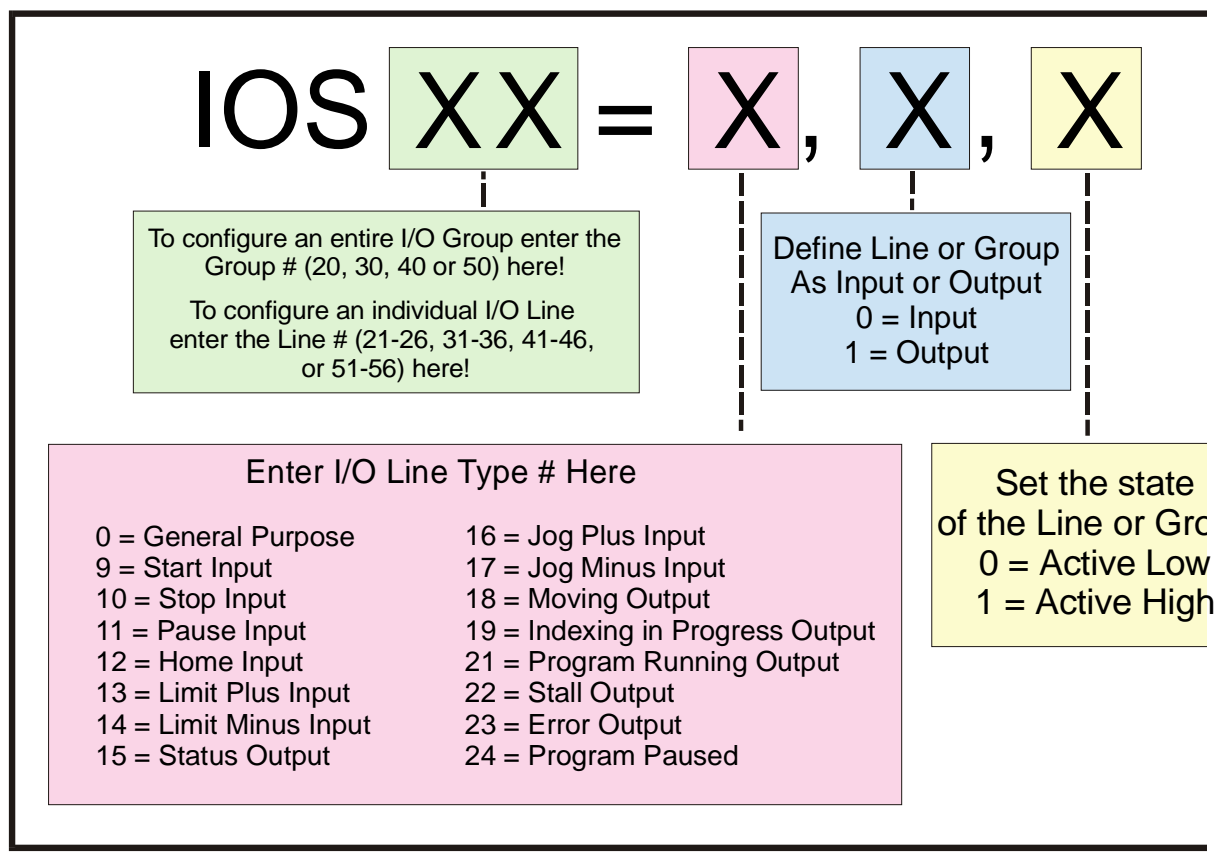

Table 6.2: IOS Variable Settings

**N** **NOTE:** When configuring a dedicated input or output, the second parameter of the IOS Variable **MUST** match the function, either input or output, or an error will occur.

## Configuring an Input

Figure 6.2 below illustrates the Input Equivalent Circuit of the Isolated I/O being used with a switch. To illustrate the usage of an input you will go through the steps to configure this switch to start a simple program at Line 1000 to index a motor 200 user units. First you must configure the I/O Line 21 as a “GO” input:

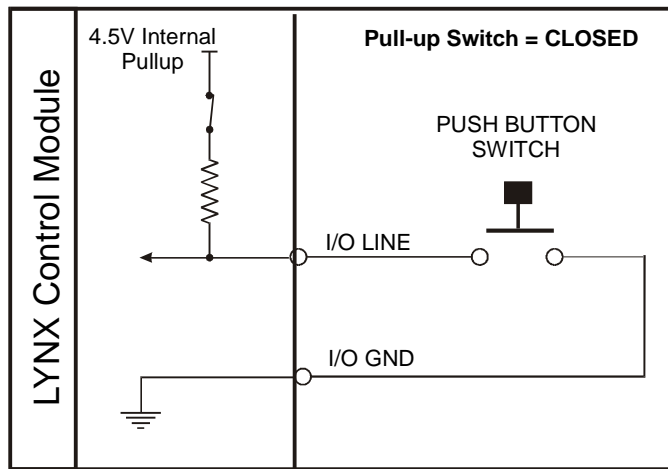

Figure 6.2: Isolated I/O Input

IOS 21 = 9, 0, 0

To break this command down:

IOS 21 - Identifies the I/O Line we are setting as 21.

9 - Configures the I/O Type to “GO”.

0 - Configures I/O as Input.

0 - Configures I/O as Active LOW.

When the Input Type “GO” is selected it will always look to execute a program located at line 1 of program memory. Therefore, to run a program at line 1000 you must do the following:

```

PGM 1      `Records program at line 1 of memory space
EXEC 1000  `Execute program located at line 1000 of memory space
END        `Terminates Program
PGM       `Switches system back to immediate mode

PGM 1000   `Records program at line 1000 of memory space
MOVR 200   `Move relative to current position 200 user units
HOLD 2     `Hold program execution until specified motion is
           `completed

END
PGM
    
```

## Configuring the Digital Filtering

User definable Digital filtering makes the LYNX well suited for noisy industrial environments. The filter setting is software selectable using the [IOF Variable](#) with a minimum guaranteed detectable pulse width of 18 microseconds to 2.3 milliseconds.

The table below illustrates the IOF settings.

The filter setting will reject any frequency above the specified bandwidth. For example:

```

IOF 2 = 3  `Set the Digital
Filter for I/O Group 20 to
3.44kHz
    
```

This setting will cause any signal above 3.44 kHz on I/O lines 21-26 to be rejected. The default filter setting for the isolated I/O groups is 7, or 215Hz.

IOF Filter Settings for the General Purpose Isolated I/O IOF=<num> (<num> = 0-7)		
Filter Setting	Cutoff Frequency	Minimum Detectable Pulse Width
0	27.5 kHz	18 microseconds
1	13.7 kHz	36 microseconds
2	6.89 kHz	73 microseconds
3	3.44 kHz	145 microseconds
4	1.72 kHz	290 microseconds
5	860 Hz	581 microseconds
6	430 Hz	1.162 milliseconds
7 (default)	215 Hz	2.323 milliseconds

Table 6.3: Digital Filter Settings for the Isolated I/O

## Configuring an Output

Figure 6.3 illustrates the Output equivalent circuit of the Isolated I/O. When used as an output the I/O line is able to sink 350mA continuous for each output, or a total of 1.5A for the entire I/O Group. See Section 9: *The Isolated Digital I/O Module* for detailed specifications. In the usage example we will use an LED on I/O Line 31 for the load. We will use the same program from the input example, only we will use the output to light the LED while the motor is moving.

```
IOS 31 = 18, 1, 1
```

Using the table on page 27 we can break this setting down as follows:  
IOS 31 - Identifies that I/O line 31 is being configured.

18 - Configures the I/O Type as "Moving".

1 - Configures the I/O line as an output.

1 - Configures the Line as "Active HIGH".

Now when the input program above is executed, the LED will be lit during the move.

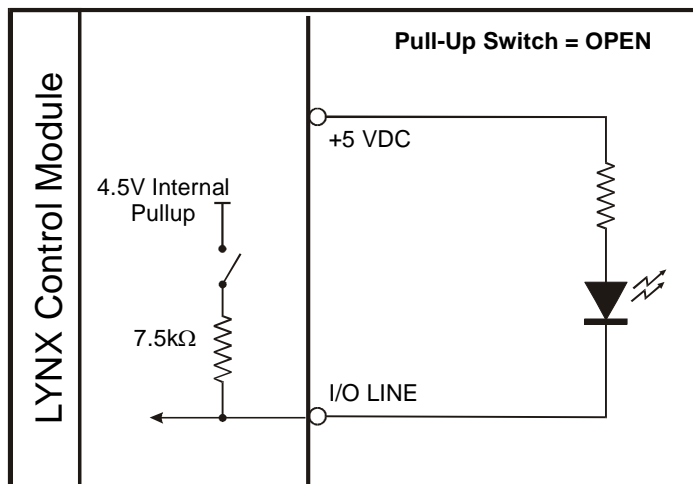

Figure 6.3: Isolated I/O Output

## The IO Variable

After configuring the I/O by means of the IOS variable, we need to be able to do two things with the I/O.

- 1] Write to an output, or group of outputs, thus setting or changing its (their) state.
- 2] Read the states of either inputs or outputs. We can use this information to either display those states to our terminal, or to set up conditions for branches and subroutine calls within a program.

We can also use this command to write or read the state of an entire I/O group.

### Read/Write a Single I/O Line

To read the state of a single input or output, the following would be typed into the terminal:

```
PRINT IO 21
```

The response from this would be 1 or 0, depending on the state of the line.

The state of an input or output in a program can be used to direct events within a LYNX program by either calling up a subroutine using the "CALL" instruction, or conditionally branching to another program address using the "BR" instruction. This would be done in the following fashion.

```
CALL MYSUB, IO 22=1
```

This would call up a subroutine labeled "MYSUB" when I/O line 22 is active.

```
BR 200, IO 22=0
```

This would branch to address 200 when I/O line 22 is inactive.

Writing to an output is accomplished by entering the following into a terminal or program:

```
IO 21=1
```

```
IO 21=0
```

This would change the state of I/O line 21.

## Read/Write an I/O Group

When using the IO variable to read the state of a group of inputs/outputs, or write to a group of outputs you would first want to configure the entire I/O group to be general purpose inputs or outputs using the IOS variable. In this case the response or input won't be a logic state of 1 or 0, but rather the decimal equivalent (0 to 63) of the 6 bit binary number represented by the entire group.

When addressing the I/O as a group the LSB (*Least Significant Bit*) will be line 1 of the group, (e.g. 21, 31, 41, 51). The MSB (*Most Significant Bit*) will be line 6 of the group (e.g. 26, 36, 46, 56).

The table on the left shows the bit weight of each I/O line in the group. It also illustrates the state should 6 LED's be connected to I/O group 20 when entering the IO variables in this exercise.

Configure the IOS variable such that group 20 is all general purpose outputs, active low or:

```
IOS 20 = 0,1,0
```

Enter the following in the terminal:

```
IO 20 = 35
```

As shown in the table I/O lines 26, 22 and 21 should be illuminated, 25, 24 and 23 should be off.

Enter this next:







```
IO 20 = 7
```







Now I/O 21, 22 and 23 should be illuminated.







```
IO 20 = 49
```

I/O 26, 25, and 21 are illuminated.

BIT WEIGHT DISTRIBUTION TABLE FOR GROUP 20 I/O					
I/O 26 MSB	I/O 25	I/O 24	I/O 23	I/O 22	I/O 21 LSB
32	16	8	4	2	1

BINARY STATE OF I/O GROUP 20 IO 20 = 35					
					
1	0	0	0	1	1
I/O 26 MSB	I/O 25	I/O 24	I/O 23	I/O 22	I/O 21 LSB

BINARY STATE OF I/O GROUP 20 IO 20 = 7					
					
0	0	0	1	1	1
I/O 26 MSB	I/O 25	I/O 24	I/O 23	I/O 22	I/O 21 LSB

BINARY STATE OF I/O GROUP 20 IO 20 = 49					
					
1	1	0	0	0	1
I/O 26 MSB	I/O 25	I/O 24	I/O 23	I/O 22	I/O 21 LSB

**Table 6.4: Binary State of Outputs**



**NOTE:** You can only write to General Purpose Outputs. If you attempt to write to and input or dedicated output type an error will occur!

# The Differential I/O

## The Clock Interface

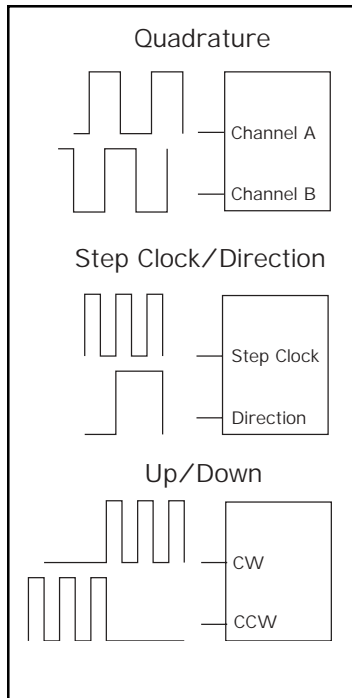

**Figure 6.4: Clock Functions**

The LYNX has four clock pairs that are used by the high speed I/O. One of these, clock pair 11 and 12, is fixed as an output and is used internally to provide step clock and direction pulses to Step Clock and Direction outputs located on Connector P1 of the LYNX Controller. The step clock output increments CTR1 (Counter 1). CTR1 may be read from or written to by software instructions in either program or immediate mode. The following table explains the clocks, as well as their default I/O line pair placement.

### Clock Types Defined

There are three basic types of clocks that may be configured for the LYNX, they are:

- 1] Quadrature
- 2] Step/Direction
- 3] Up/Down

These clock functions are illustrated in figure 6.4.

#### Quadrature

The quadrature clock function is the most commonly used input clock function. This is the default setting for each high speed I/O channel except 11 & 12. This clock function will typically be used for closed loop control (encoder feedback) or for following applications

#### Step/Direction

The step/direction clock function would typically be used in an application where a secondary or tertiary clock output is required to sequentially control an additional axis.

#### Up/Down

The up/down clock type would typically be used as an output function where a secondary axis is being driven by a stepper or servo drive with dual-clock direction control circuitry.

The Four Clocks				
Clock #	I/O Line Pair	Slot Position	Counter	Function
1	11 & 12	None	CTR1	This clock is internally generated motion clock. It provides step clock and directional control to the driver section. This clock is not available on any external connector.
2	13 & 14	Slot 2	CTR2	May be configured as an input or output. By default this is configured as a quadrature input. It can be configured as a secondary clock output electronically geared to CLK1.
3	15 & 16	Slot 3	CTR3	May be configured as an input or output. By default this is configured as a quadrature input. It can be configured as a tertiary clock output electronically geared to CLK1.
4	17	Slot 2	None	May be configured as a high speed input or an output. As an output it is a 1MHz reference clock.
	18	Slot 3	None	May be configured as a high speed input or output. As an output it is a 10MHz reference clock.

**Table 6.5: The Four Clocks and Their Default Line Placement**

## Configuring The Differential I/O - The IOS Variable

The high speed differential I/O is configured by means of the IOS variable, and is used in the the same fashion in which the isolated I/O is configured. The main difference lies in that there are three additional parameters which need to be set in configuring the triggering, clock type, and ratio mode setting.

It is important to note that the high speed differential I/O lines may be used for the same input or output functions as the isolated digital I/O where the higher speed capabilities of the differential I/O is required. However, for purposes of this example we will only illustrate the clock functions associated with the high speed differential I/O. Figure 6.5 following illustrates the IOS variable settings for the high speed differential I/O.

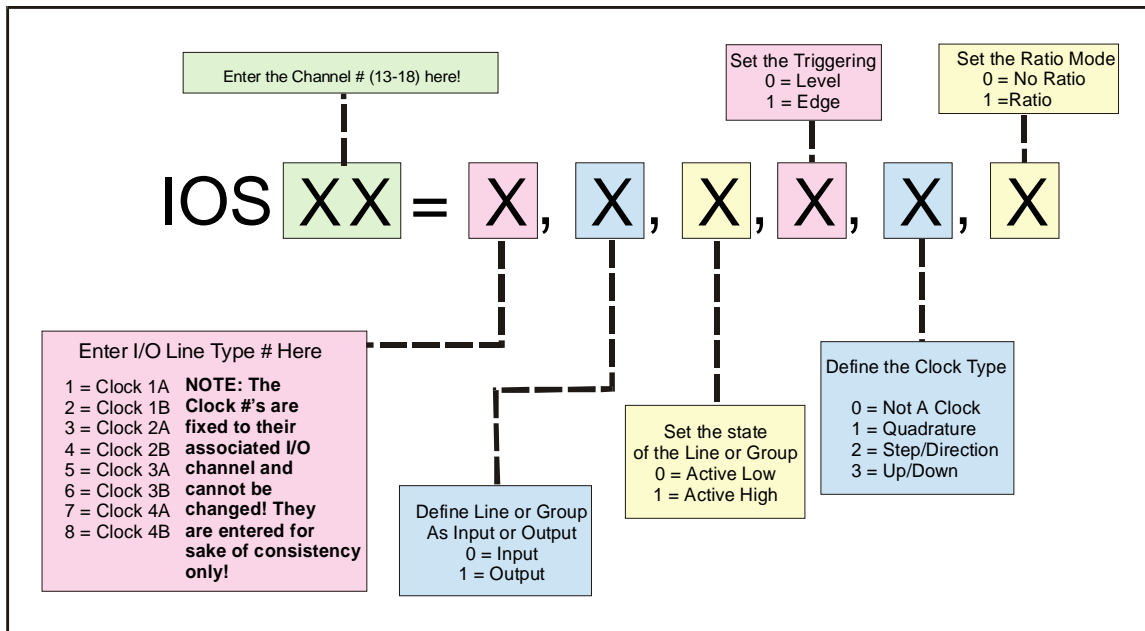

Figure 6.5: IOS Variable Settings for the High Speed Differential I/O

## Configuring an Input

Clocks 2, 3 and 4 can be configured as high speed inputs, or as a general purpose input in the same fashion as the Isolated I/O. In configuring the Differential I/O line as a general purpose input you would typically use the "+" line of the line pair. You cannot use both lines as separate I/O lines. The figure below shows the Input Equivalent Circuit with the I/O line pair connected to channel A of a differential encoder. This feature

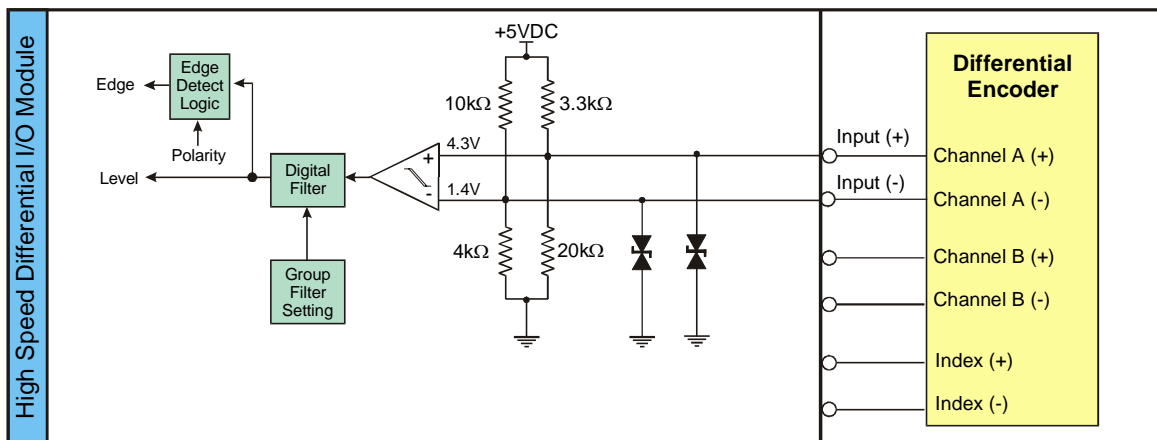

Figure 6.6: Differential I/O Input Equivalent Circuit

is demonstrated in *Typical Functions of the Differential I/O: Connecting and Using an Encoder*. Clocks 2, 3 and 4 are set up as Quadrature inputs by default. The defaults for each I/O Line Pair are:

- IOS 13 = 3, 0, 1, 0, 1, 0
- IOS 14 = 4, 0, 1, 0, 1, 0
- IOS 15 = 5, 0, 1, 0, 1, 0
- IOS 16 = 6, 0, 1, 0, 1, 0
- IOS 17 = 7, 0, 1, 0, 1, 0
- IOS 18 = 8, 0, 1, 0, 1, 0

### Setting the Digital Input Filtering for the Differential I/O

User definable Digital filtering makes the LYNX well suited for noisy industrial environments. The filter setting is software selectable using the *IOF Variable* with a minimum guaranteed detectable pulse width of 18 microseconds to 2.3 milliseconds. The table (right) illustrates the IOF settings.

IOF Filter Settings for the High Speed Differential I/O IOF=<num> (<num> = 0-7)		
Filter Setting	Cutoff Frequency	Minimum Detectable Pulse Width
0 (default)	5.00 MHz	100 nanoseconds
1	2.50 MHz	200 nanoseconds
2	1.25 MHz	400 nanoseconds
3	625 kHz	800 nanoseconds
4	313 kHz	1.6 microseconds
5	156 kHz	3.2 microseconds
6	78.1 kHz	6.4 microseconds
7	39.1 kHz	12.8 microseconds

Table 6.6: Digital Filter Settings for the Differential I/O

### Configuring an Output

The Differential I/O Group 10 has 3 Channels (Line Pairs 13 & 14, 15 & 16, and 17 & 18) that can be configured as an output by the user and One Channel (Line Pairs 11 & 12) that is configured as output only. (SCK and DIR on the Control Module.) These outputs can be configured as high speed outputs or 0 to 5VDC general purpose outputs by using the IOS variable. The high speed clock outputs have the following restrictions:

Line Pairs 11/12, 13/14 and 15/16 can be configured to Step Clock/Direction or Up/Down.

Line Pair 17/18 is limited to 1MHz Reference Out (17) and 10MHz Reference Out (18).

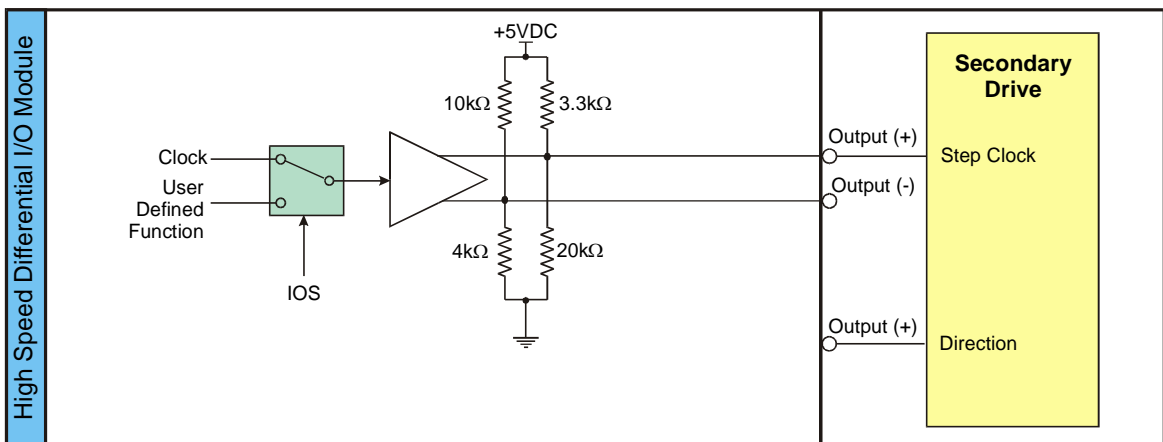

Figure 6.7: Differential I/O Output Equivalent Circuit

In the Equivalent Circuit in Figure 6.7 an Output is being used as Step or Direction on a driver.

For the configuration example, use I/O line 13 for the output. Since by default the line is a quadrature input we must configure it to be a Step/Direction Output by setting the IOS Variable to the following:

IOS 13 = 3, 1, 0, 1, 2, 0

This breaks down as:

IOS 13 - Identifies the line being configured as 13.  
3 - Sets the I/O Type to Clock 2A (default).  
1 - Sets it as an output.  
0 - Sets Logic at Low True.  
1 - Edge Triggered.  
2 - Sets the Clock Type to Step/Direction.  
0 - No Ratio.

---

## Typical Functions of the Differential I/O

### *Connecting and Using an Encoder*

The differential I/O module can be set up to receive encoder feedback using either a differential or a single ended output encoder. A differential output encoder would typically be connected to differential input pairs 13 and 14 (P1, pins 1 – 4) as the default setting for I/O 13 and 14 is set up to accept a quadrature encoder input. Channel A of the encoder would be connected to input pair 13 (P1, pins 1 & 2) and channel B would be connected to input pair 14 (P1, pins 3 & 4). A single ended output encoder would be connected to the positive inputs of the input pair. Whether you use a differential encoder or single ended encoder the same software commands and settings will be used.

In setting up your system to run with an encoder you will be using the following variables, flags, and instructions. The variables used with an encoder will be *MUNIT*, *EUNIT*, *CTR2*, and *POS*. The Encoder Enable Flag *EE*, and the instruction *MOVR* will be used. The block diagram to the left illustrates a LYNX system with the encoder and drive connections that will be used in this example.

The sequence of commands (in bold) used to make this setup function would be as follows:

```
'Set the MUNIT Variable to 51,200 steps/rev
MUNIT = 51200
'Set encoder enable to TRUE (1), default value = FALSE (0)
EE = 1
'Set the EUNIT (Encoder Units) variable to 800 (200 [Encoder Resolution] X 4 [Quadrature Input])
This means that 1 unit of motion, or 1 POS, is equal to 800 encoder counts. In this instance it will be
1 rotation of the motor.
EUNIT = 800
'Save the above flag and variable settings
SAVE
```

Now you may begin to use the motion command *MOVR*, as well as *PRINT POS* and *PRINT CTR2* to see the number of encoder counts fed back to the system.

```
'Set the motor position to 0
POS = 0
'Move the motor 2 units (2 X EUNIT) relative to current position.
MOVR 2
'Print the value of CTR2. This value will indicate the number of encoder counts that the motor has
moved. Your terminal should echo back the number "1600".
```

```
PRINT CTR2
'Print the position of the motor. Your terminal should echo "2.000"
PRINT POS
```

By printing the variable CTR2 (CTR2 = EUNIT X POS) we can view the distance the motor has traveled in raw encoder counts, or by printing POS you can see the distance of travel represented by number of units relative to 0.

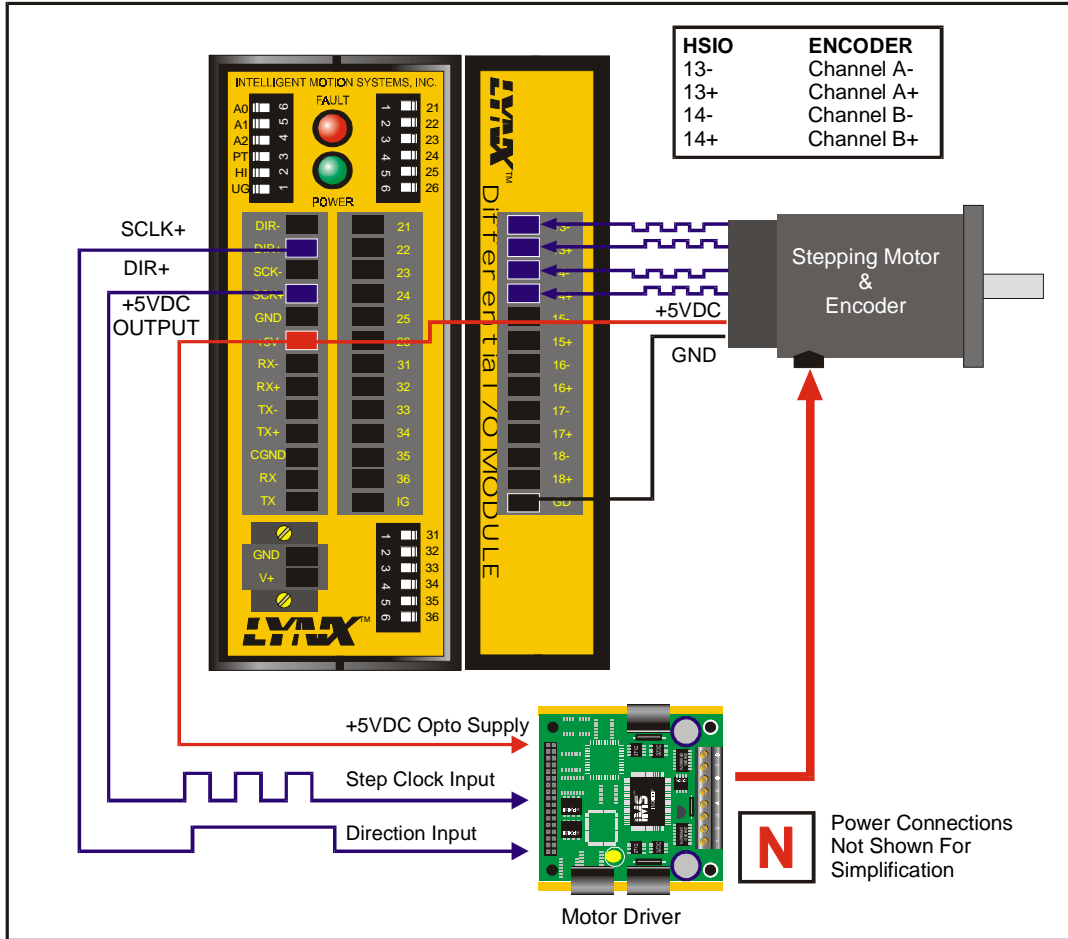

Figure 6.8: Connecting and Using an Encoder

### Translating the EUNIT Variable to a Dimension of Distance

The **EUNIT**, or *Encoder Unit* variable, is the scaling factor used to translate Encoder steps to a dimension of distance, or *user units*. At this point you should already be familiar with the MUNIT variable. The main difference between the two is as follows: By using **MUNIT** scaling factor you monitor the position of an axis based upon the value of **CTR1**, the register that contains the actual count of clock pulses sent to the drive. The number of pulses is then scaled to user units by setting the MUNIT Variable to the appropriate scaling factor for the type of units being used, be they inches, millimeters, degrees, etc. Then the **POS** variable tracks position in the user units specified. Example:

$$\text{User Unit (POS)} = \text{CTR1} \div \text{MUNIT} \quad \text{where EE (Encoder Enable) Flag} = \text{FALSE (0)}$$

By setting the state of EE, the master encoder function enable flag, to a true state you will monitor the position of an axis based upon the actual position of the motor shaft as it is fed back to the Control Module

by a motor mounted encoder. The actual count of encoder pulses received by the Control Module is maintained by the register [CTR2](#), (if the encoder is connected to I/O line pair 13 & 14) with the [EUNIT](#) variable scaling it to user units. Example:

$$\text{User Unit (POS)} = \text{CTR2} \div \text{EUNIT} \quad \text{where EE (Encoder Enable) Flag} = \text{TRUE}(1)$$

When using the EUNIT scaling factor it is important to understand that you **MUST** set the EUNIT variable AND the MUNIT variable to the same scaling factor for accurate position monitoring. In the example below you will use a hypothetical system designed from the following components:

- An IMS IB462H Half/Full Step driver configured for Half Step Operation.
- A 1.8° Stepping Motor mounted to a 20cm linear slide.
- A 200 Line Encoder.

You will want to use millimeters for our user unit. The IB462H in half step mode will need 400 clock pulses to turn the motor one revolution. The pitch on the leadscrew is such that one millimeter of linear motion will require 25 clock pulses.  $400 \text{ steps/rev} \div 25 \text{ steps/mm} = 16 \text{ mm/rev}$ . Therefore, you would set the MUNIT variable as follows:

$$\text{MUNIT} = 400/16$$

Now, when you give a MOVR 20 instruction, the axis will index 20 millimeters. Now to set the EUNIT Variable. We have a 200 line encoder connected to a quadrature clock input. This will mean that 1 revolution will equal 800 Encoder Pulses, you will have to use the same scaling factor as we did for MUNIT as there will still be 16mm per revolution:

$$\text{EUNIT} = 800/16$$

Both values must be set, and both must be set to the same scaling factor. With the EE = 1 a MOVR 20 command will still index the axis 20 millimeters, but position will be maintained by CTR2.

### *Half Axis Operation (Follower)*

In half axis mode the master clock is taken from a clock input 2, 3 or 4 (line pairs 13-14, 15-16 or 17-18) which have been set for input, clock type and ratio enabled. This is the factor at which the count rate out to the primary drive will follow the external clock in half axis mode. This clock input would typically be connected to differential input pairs 15 and 16 (P1, pins 5 – 8). This could be set up as any of the available clock types. If half axis mode is enabled (HAE), the primary axis of the control will follow the clock input with the ratio specified by the [HAS variable](#).

In order to use the HAS (Half axis mode scaling) variable the [HAE flag](#) must be set to true (1). For example, to set the half axis scale factor to .5, where the drive will follow the external Clock input with a ratio of 1 count to the drive for every two counts from the external clock, you would use the command: SET HAS = .5 (or HAS = .5). Figure 6.9 illustrates the connections for using this mode of operation using a clock input from an encoder.

The sequence of commands used to make this setup function would be as follows:

```
'Set IOS 15 to ratio mode
IOS 15 = 5, 0, 1, 0, 1, 1
'Set IOS 16 to ratio mode
IOS 16 = 6, 0, 1, 0, 1, 1
'Half axis enable set to true
HAE = 1
'Half axis scaling to .5 (1 output clock pulse to every 2 input clock pulses)
HAS = .5
```

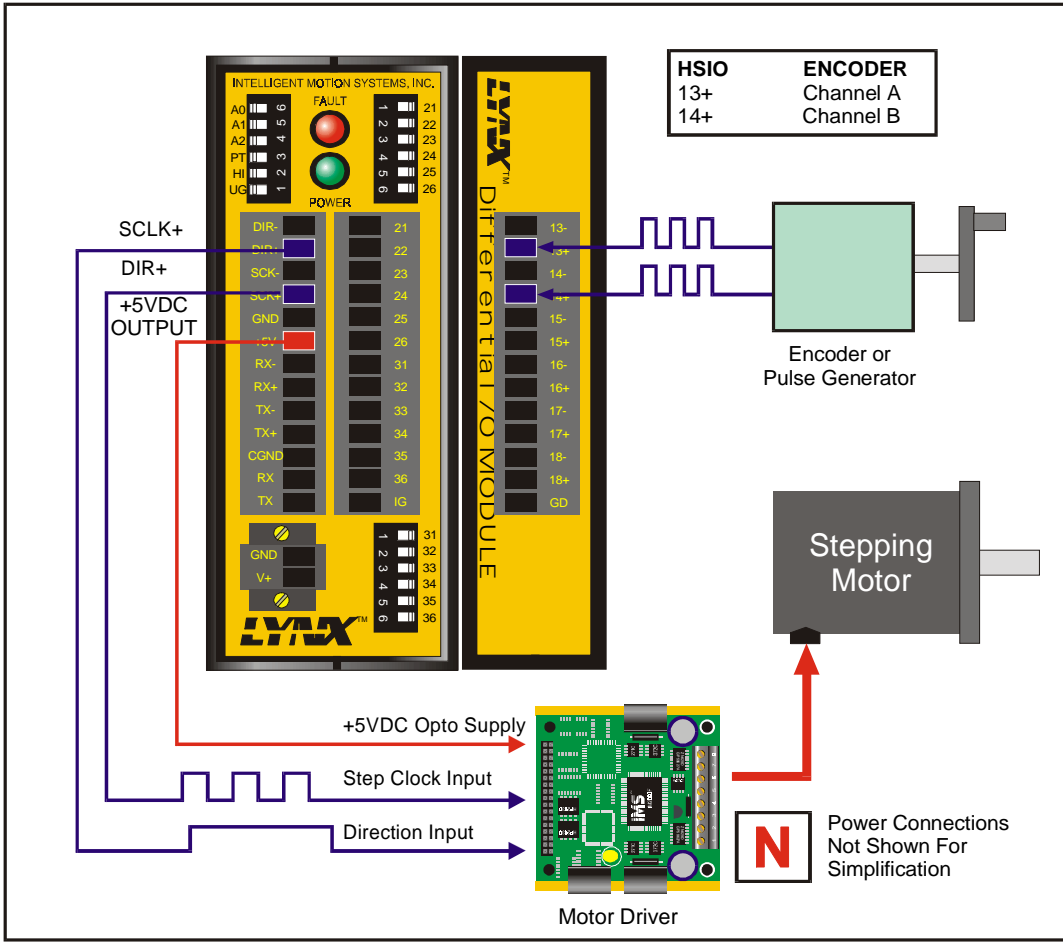

Figure 6.9 Half Axis Mode (Following)

**N** **NOTE:** The HAS variable must be set to less than 1 or Error Code 9004, "Ratio Out of Range" will occur.

**One and a Half Axis Operation (RATIOE)**

A secondary drive can be connected to a pair of differential outputs. The secondary driver will operate off of the differential output pair 15 and 16 (I/O pair 13 and 14 can also operate in this mode). Setting the ratio mode to TRUE (1) for the differential output clock (IOS) specifies a secondary drive function. Then when ratio mode is enabled (RATIOE); the secondary axis will follow the primary axis with the ratio specified by the RATIO variable.

The sequence of commands used to make this setup function would be as follows:

- 'Set IOS 15 to step/direction clock type, and ratio mode  
IOS 15 = 5, 0, 1, 0, 2, 1
- 'Set IOS 16 to step/direction clock type, and ratio mode  
IOS 16 = 6, 0, 1, 0, 2, 1
- 'Set Ratio Mode Enable Flag to TRUE(1)

RATIOE = 1  
 'Set RATIO variable to .5 for the secondary drive  
 RATIO = .5

With this setup, the motor on the secondary drive will move half the distance of the primary.

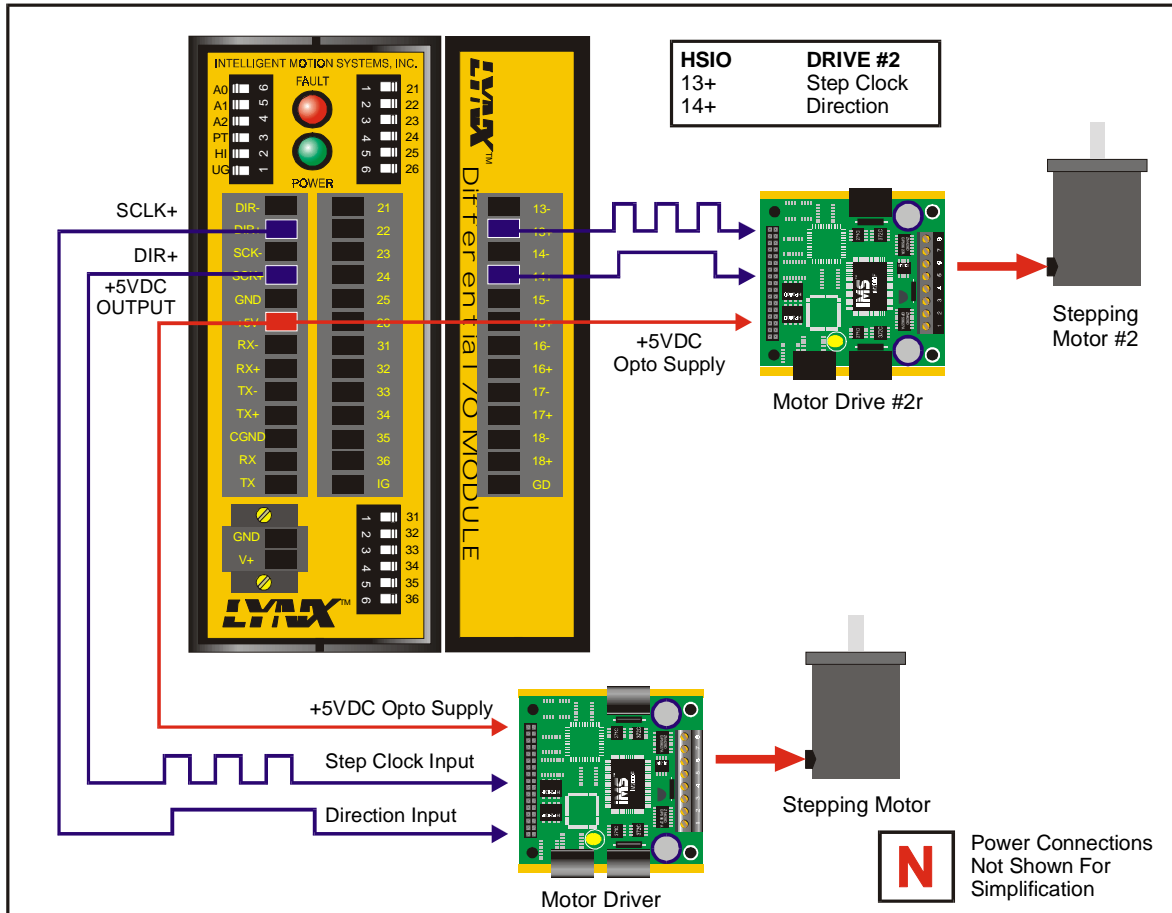

Figure 6.10: One and a Half Axis Operation

**N** **NOTE:** The RATIO variable must be set to less than 2 or -2 or Error Code 9004, "Ratio Out of Range" will occur.



## Power Requirements

Power Requirements and Specifications	
Input Voltage	+12 to +75 VDC Unregulated or +5VDC $\pm$ 5%
Input Current	250mA (5VDC input) 165mA (+12VDC Input)* 95.0mA (+48 VDC Input)* 84.5mA (+75VDC Input)*  *I/O and +5VDC output unloaded (Control Module Only)
Output Voltage	+5VDC $\pm$ 5%
Output Current	150mA (Internally Limited)

Table 7.1: Power Requirements for the LYNX Control Module

## Connection Overview

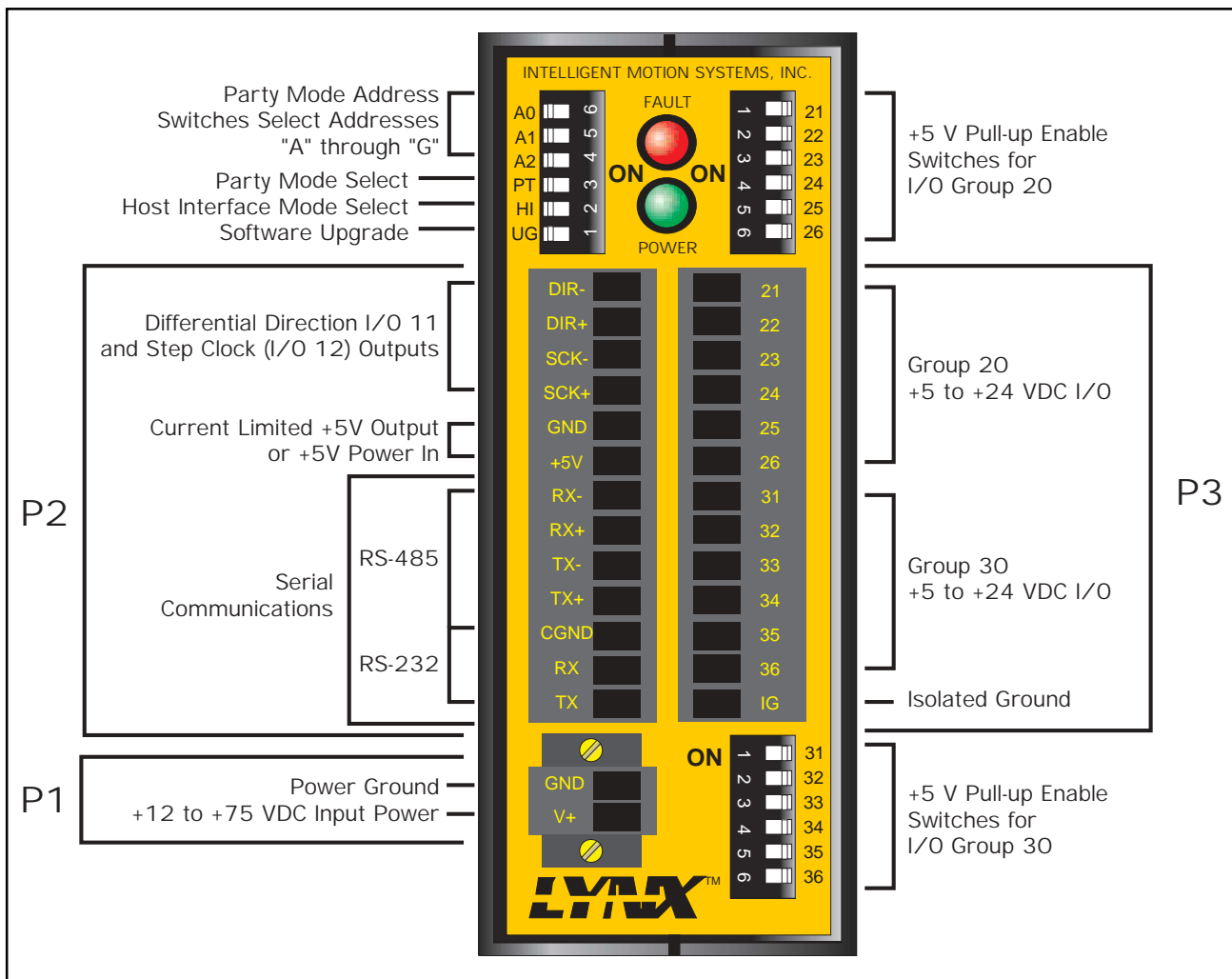

Figure 7.2: LYNX Control Module, Switches and Connections

## LED Indicators

LED Color	Meaning
Green	Power On
Red	System or software fault detected. The user can choose to enable or disable the indicator by setting the <a href="#">FAULT</a> flag. FAULT=TRUE (1) will cause the LED to illuminated whenever an <a href="#">ERROR</a> occurs.

**Table 7.2: LYNX Control Module LED Indicators**

## Pin Assignment and Description

P1 - Two Position Screw Lock Terminal: Input Power Connection		
Pin #	Function	Description
1	Power Ground	Power ground for the unregulated power supply.
2	Unregulated Power Supply Input (V+)	12 – 75 VDC unregulated power input if an external power supply is to be used.

**Table 7.3: LYNX Control Module Connector P1 Pin Configuration**

P2 - 13 Position Removeable Terminal Connector: Motion Signals, Regulated Power and Communications		
Pin #	Function	Description
1	Direction - (I/O 11)	Pins 1 and 2 are the differentially buffered signal for group 1, #1 or I/O 11. The default for this signal is the direction output for the primary motor drive of the controller. If desired, this signal may be programmed as a quadrature or up/down clock type or a user output. This I/O may not be programmed as an input.
2	Direction + (I/O 11)	See description above.
3	Step Clock - (I/O 12)	Pins 3 and 4 are the differentially buffered signal for group 1, #2 or I/O 12. The default for this signal is the step clock output for the primary motor drive of the controller. If desired, this signal may be programmed as a quadrature or up/down clock type or a user output. This I/O may not be programmed as an input.
4	Step Clock + (I/O 12)	See description above.
5	Ground (GND)	Common to the power ground on pin 1 of connector P1. This is provided as a signal return for the motion control signals and the power return for the 5VDC in/out on pin 6.
6	+5VDC	This can be 5 volts in or out. When the control module is powered via connector P1, this terminal provides up to 150 ma of regulated 5VDC for user circuits such as encoders. If desired, however, this terminal may be used as a power input connection. It should be noted that a fully configured LYNX system may require up to 800 ma current from this 5 VDC supply.
7	RS-485 RX- Input	Pins 7 and 8 are the differential receive inputs for the RS-485 communications interface. They should be left disconnected if they are not used. For specific connection information, see <a href="#">Section 5: The Communications Interface</a> .
8	RS-485 RX+ Input	See description above.
9	RS-485 TX- Output	Pins 9 and 10 are the differential transmit outputs for the RS-485 communications interface. They should be left disconnected if they are not used. For specific connection information, see <a href="#">Section 5: The Communications Interface</a> .
10	RS-485 TX+ Output	See description above.
11	Communications Ground (CGND)	Isolated communications ground signal for both RS-485 and RS-232. For specific connection information, see <a href="#">Section 7: The Communications Interface</a> .
12	RS-232 RX Input	Receive input from the host computer. For specific connection information, see <a href="#">Section 5: The Communications Interface</a> .
13	RS-232 TX Output	Transmit output to the host computer. For specific connection information, see <a href="#">Section 5: The Communications Interface</a> .

**Table 7.4: LYNX Control Module Connector P2 Pin Configuration**

P3 - 13 Position Removeable Terminal Connector: Isolated Digital I/O		
Pin #	Function	Description
1 - 8	I/O Group 20 Lines 21 - 26	Signals are individually programmable as inputs or outputs (see description of the <a href="#">IOS command</a> in the <a href="#">Part 3: Software Reference</a> of this manual). Inputs are CMOS logic level compatible and can accept inputs to 28 volts. Noise rejection is available via digital filtering. Outputs are open drain. I/Os each have individually switchable 7.5 Kohm pull up resistors to 5VDC. Outputs can switch inductive, resistive or incandescent loads. Refer to <a href="#">Section 6: Configuring the Digital I/O</a> for usage and specifications.
7 - 12	I/O Group 30 Lines 31 - 36	See description above.
13	Isolated I/O Ground	Isolated common signal return for groups 20 and 30 I/O. Isolated from the power and communication grounds.

**Table 7.5: LYNX Control Module Connector P3 Pin Configuration**

## Switch Assignments

Configuration Switches: Read at Power-On or System Reset. May be Overridden by Software Settings																																						
Switch #	Function	Description																																				
1	Firmware Upgrade	When this switch is on, the controller firmware may be upgraded using the IMS upgrade program.																																				
2	Host Interface	When this switch is on, the controller will act as the Host Interface Controller for communications in a multiple controller system. When it is off, the controller is a slave in the system and will not act as the host interface. For more information, see <a href="#">Section 5: The Communications Interface</a> . This switch may be overridden in software by the <a href="#">HOST flag</a> .																																				
3	Party Mode	When this switch is on, party mode communications is selected. When it is off, single mode communications is selected. For more information, see <a href="#">Section 5: The Communications Interface</a> .																																				
4	Party Mode Address Bit 0 - A0	Sets party mode communications node address. See also <a href="#">DN instruction</a> in the Software Reference <table border="1" style="margin-left: auto; margin-right: auto;"> <thead> <tr> <th>A2</th> <th>A1</th> <th>A0</th> <th>Address</th> </tr> </thead> <tbody> <tr> <td>OFF</td> <td>OFF</td> <td>OFF</td> <td>None</td> </tr> <tr> <td>OFF</td> <td>OFF</td> <td>ON</td> <td>"A"</td> </tr> <tr> <td>OFF</td> <td>ON</td> <td>OFF</td> <td>"B"</td> </tr> <tr> <td>OFF</td> <td>ON</td> <td>ON</td> <td>"C"</td> </tr> <tr> <td>ON</td> <td>OFF</td> <td>OFF</td> <td>"D"</td> </tr> <tr> <td>ON</td> <td>OFF</td> <td>ON</td> <td>"E"</td> </tr> <tr> <td>ON</td> <td>ON</td> <td>OFF</td> <td>"F"</td> </tr> <tr> <td>ON</td> <td>ON</td> <td>ON</td> <td>"G"</td> </tr> </tbody> </table>	A2	A1	A0	Address	OFF	OFF	OFF	None	OFF	OFF	ON	"A"	OFF	ON	OFF	"B"	OFF	ON	ON	"C"	ON	OFF	OFF	"D"	ON	OFF	ON	"E"	ON	ON	OFF	"F"	ON	ON	ON	"G"
A2	A1		A0	Address																																		
OFF	OFF		OFF	None																																		
OFF	OFF		ON	"A"																																		
OFF	ON		OFF	"B"																																		
OFF	ON		ON	"C"																																		
ON	OFF	OFF	"D"																																			
ON	OFF	ON	"E"																																			
ON	ON	OFF	"F"																																			
ON	ON	ON	"G"																																			
5	Party Mode Address Bit 1 - A1																																					
6	Party Mode Address Bit 2 - A2																																					

**Table 7.6: LYNX Control Module Configuration Switches**

Group 20 I/O Pull-Up Switches: Can Be Changed at any Time, Usable for Exercising Inputs		
Switch #	Function	Description
1 - 6	Individual Switches for I/O Group 20 Pull-Ups.	When this switch is on, the I/O is pulled up through an internal 7.5 Kohm resistor to 5VDC. Can be used to simulate the activation of an input while testing system software..

**Table 7.7: LYNX Control Module Group 20 I/O Pull-up Switches**

Group 30 I/O Pull-Up Switches: Can Be Changed at any Time, Usable for Exercising Inputs		
Switch #	Function	Description
1 - 6	Individual Switches for I/O Group 30 Pull-Ups.	When this switch is on, the I/O is pulled up through an internal 7.5 Kohm resistor to 5VDC. Can be used to simulate the activation of an input while testing system software..

**Table 7.8: LYNX Control Module Group 30 I/O Pull-up Switches**

# Section 8

## The LYNX Control Module (Combination)

### Section Overview

The Control Module (Combination) (IMS Part # LX-CM200-000) offers the user of purchasing a LYNX Control Module with 3 differential I/O Channels and 6 Isolated I/O lines instead of the standard 2 Isolated I/O groups. This section will cover:

- Hardware Specifications
  - Environmental Specifications
  - Mechanical Specifications
  - Power Requirements
- Connection Overview
- LED Indicators
- Pin Assignments
- Switch Assignments

### Hardware Specifications

#### *Environmental Specifications*

Ambient Operating Temperature ..... 0 to +50 degrees C  
 Storage Temperature ..... -20 to +70 degrees C  
 Humidity ..... 0 to 90% non-condensing

#### *Mechanical Specification*

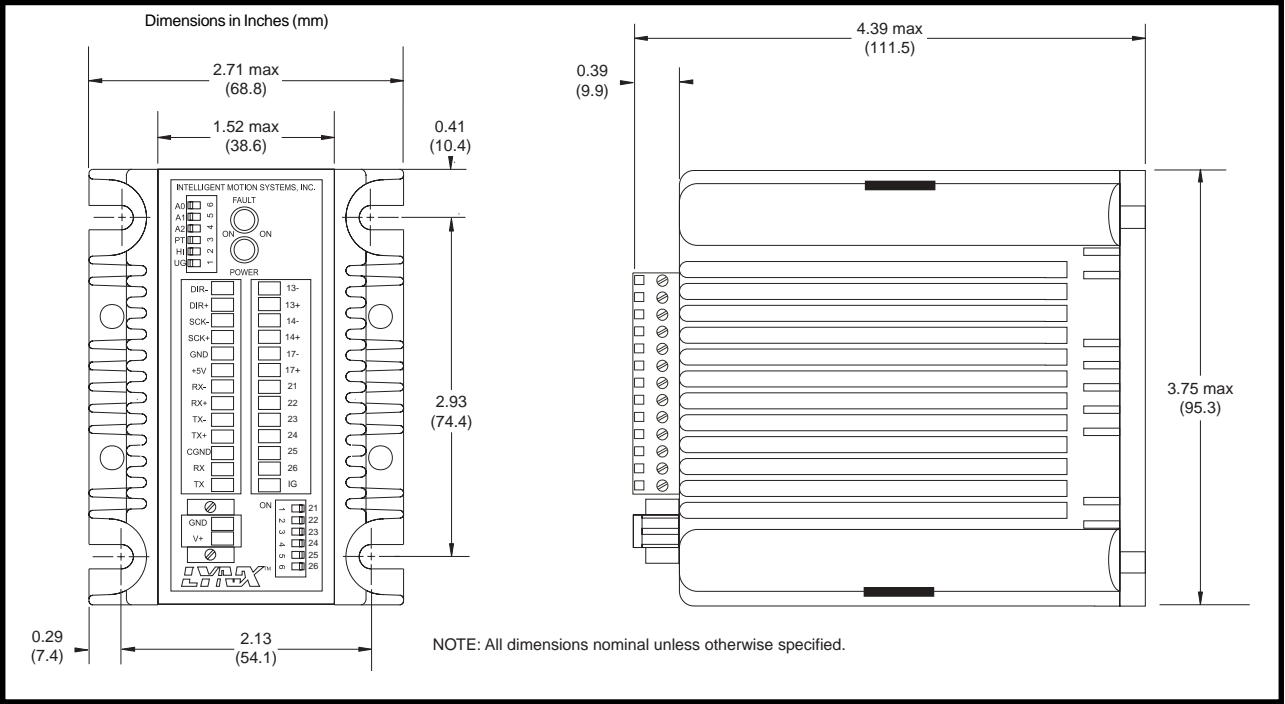

**Figure 8.1: LYNX Control Module (Combination) Dimensions**

## Power Requirements

Power Requirements and Specifications	
Input Voltage	+12 to +75 VDC Unregulated or +5VDC $\pm$ 5%
Input Current	250mA (5VDC input) 165mA (+12VDC Input)* 95.0mA (+48 VDC Input)* 84.5mA (+75VDC Input)*  *I/O and +5VDC output unloaded (Control Module Only)
Output Voltage	+5VDC $\pm$ 5%
Output Current	150mA (Internally Limited)

**Table 8.1: Power Requirements for the LYNX Control Module (Combination)**

## Connection Overview

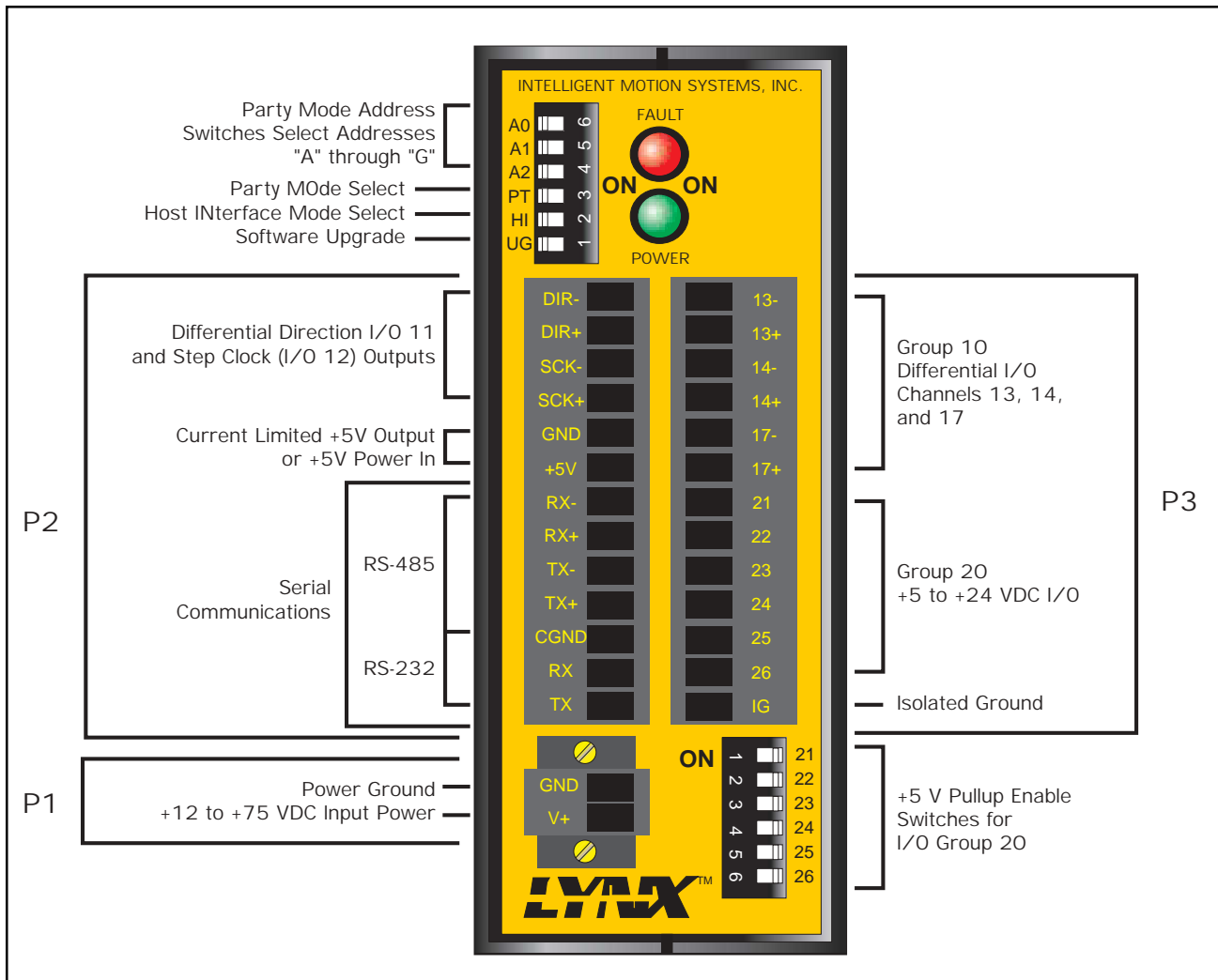

**Figure 8.2: LYNX Control Module (Combination) Connections and Switches**

## LED Indicators

LED Color	Meaning
Green	Power On
Red	System or software fault detected. The user can choose to enable or disable the indicator by setting the <a href="#">FAULT</a> flag. FAULT=TRUE (1) will cause the LED to illuminated whenever an <a href="#">ERROR</a> occurs.

**Table 8.2: LYNX Control Module LED Indicators**

## Pin Assignment and Description

P1 - Two Position Screw Lock Terminal: Input Power Connection		
Pin #	Function	Description
1	Power Ground	Power ground for the unregulated power supply.
2	Unregulated Power Supply Input (V+)	12 – 75 VDC unregulated power input if an external power supply is to be used.

**Table 8.3: LYNX Combination Control Module Connector P1 Pin Configuration**

P2 - 13 Position Removeable Terminal Connector: Motion Signals, Regulated Power and Communications		
Pin #	Function	Description
1	Direction - (I/O 11)	Pins 1 and 2 are the differentially buffered signal for group 1, #1 or I/O 11. The default for this signal is the direction output for the primary motor drive of the controller. If desired, this signal may be programmed as a quadrature or up/down clock type or a user output. This I/O may not be programmed as an input.
2	Direction + (I/O 11)	See description above.
3	Step Clock - (I/O 12)	Pins 3 and 4 are the differentially buffered signal for group 1, #2 or I/O 12. The default for this signal is the step clock output for the primary motor drive of the controller. If desired, this signal may be programmed as a quadrature or up/down clock type or a user output. This I/O may not be programmed as an input.
4	Step Clock + (I/O 12)	See description above.
5	Ground (GND)	Common to the power ground on pin 1 of connector P1. This is provided as a signal return for the motion control signals and the power return for the 5VDC in/out on pin 6.
6	+5VDC	This can be 5 volts in or out. When the control module is powered via connector P1, this terminal provides up to 150 ma of regulated 5VDC for user circuits such as encoders. If desired, however, this terminal may be used as a power input connection. It should be noted that a fully configured LYNX system may require up to 800 ma current from this 5 VDC supply.
7	RS-485 RX- Input	Pins 7 and 8 are the differential receive inputs for the RS-485 communications interface. They should be left disconnected if they are not used. For specific connection information, see <a href="#">Section 5: The Communications Interface</a> .
8	RS-485 RX+ Input	See description above.
9	RS-485 TX- Output	Pins 9 and 10 are the differential transmit outputs for the RS-485 communications interface. They should be left disconnected if they are not used. For specific connection information, see <a href="#">Section 5: The Communications Interface</a> .
10	RS-485 TX+ Output	See description above.
11	Communications Ground (CGND)	Isolated communications ground signal for both RS-485 and RS-232. For specific connection information, see <a href="#">Section 7: The Communications Interface</a> .
12	RS-232 RX Input	Receive input from the host computer. For specific connection information, see <a href="#">Section 5: The Communications Interface</a> .
13	RS-232 TX Output	Transmit output to the host computer. For specific connection information, see <a href="#">Section 5: The Communications Interface</a> .

**Table 8.4: LYNX Combination Control Module Connector P2 Pin Configuration**

P3 - 13 Position Removeable Terminal Connector: Combination I/O		
Pin #	Function	Description
1	I/O 13-	Pins 1 and 2 are the differentially buffered signal for group 10, I/O 13. This channel is configured by means of the <a href="#">IOS Instruction</a> . For usage details see <a href="#">Section 6: Configuring the Digital I/O</a> .
2	I/O 13+	See description above.
3	I/O 14-	Pins 3 and 4 are the differentially buffered signal for group 10, I/O 14. This channel is configured by means of the <a href="#">IOS Instruction</a> . For usage details see <a href="#">Section 6: Configuring the Digital I/O</a> .
4	I/O 14+	See description above.
5	I/O 17-	Pins 5 and 6 are the differentially buffered signal for group 10, I/O 17. This channel is configured by means of the <a href="#">IOS Instruction</a> . For usage details see <a href="#">Section 6: Configuring the Digital I/O</a> .
6	I/O 17+	See description above.
7 - 12	I/O Group 20 Lines 21 - 26	Signals are individually programmable as inputs or outputs (see description of <a href="#">IOS command</a> in Part 3: The Software Reference of this manual). Inputs are CMOS logic level compatible and can accept inputs to 24 volts. Noise rejection is available via digital filtering. Outputs are open drain. I/Os each have individually switchable 7.5 Kohm pull up resistors to 5VDC. Outputs can switch inductive, resistive or incandescent loads. Refer to <a href="#">Section 6: Configuring the Digital I/O</a> for more information.
13	Isolated Ground For Group 20 I/O	Isolated common signal return for group 20 I/O. Isolated from the power and communication grounds.

**Table 8.5: LYNX Combination Control Module Connector P3 Pin Configuration**

## Switch Assignments

Configuration Switches: Read at Power-On or System Reset. May be Overridden by Software Settings			
Switch #	Function	Description	
1	Firmware Upgrade	When this switch is on, the controller firmware may be upgraded using the IMS upgrade program.	
2	Host Interface	When this switch is on, the controller will act as the Host Interface Controller for communications in a multiple controller system. When it is off, the controller is a slave in the system and will not act as the host interface. For more information, see <a href="#">Section 5: The Communications Interface</a> . This switch may be overridden in software by the <a href="#">HOST flag</a> .	
3	Party Mode	When this switch is on, party mode communications is selected. When it is off, single mode communications is selected. For more information, see <a href="#">Section 5: The Communications Interface</a> .	
4	Party Mode Address Bit 0 - A0	Sets party mode communications node address. See also <a href="#">DN instruction</a> in the Software Reference	
5	Party Mode Address Bit 1 - A1		A2      A1      A0      Address
			OFF    OFF    OFF    None
6	Party Mode Address Bit 2 - A2		OFF    OFF    ON     "A"
			OFF    ON     OFF    "B"
			OFF    ON     ON     "C"
			ON     OFF    OFF    "D"
		ON     OFF    ON     "E"	
		ON     ON     OFF    "F"	
		ON     ON     ON     "G"	

**Table 8.6: LYNX Combination Control Module Configuration Switches**

Group 20 I/O Pull-Up Switches: Can Be Changed at any Time, Usable for Exercising Inputs		
Switch #	Function	Description
1 - 6	Individual Switches for I/O Group 20 Pull-Ups.	When this switch is on, the I/O is pulled up through an internal 7.5 Kohm resistor to 5VDC. Can be used to simulate the activation of an input while testing system software..

**Table 8.7: LYNX Combination Control Module Group 20 I/O Pull-up Switches**

# Section 9

## *The Isolated Digital I/O Module*

### Section Overview

The Isolated I/O Module (IMS Part # LX-DI100-000) offers the user an additional 12 Isolated +5 to 24VDC General Purpose I/O lines in two groups of six each (Groups 40 and 50) for a total of 24 individually programmable I/O when used with the LYNX CM100 Control Module or 18 when used with the CM200 Combination Control Module.

- Hardware Specifications
  - Environmental Specifications
  - Mechanical Specifications
- Pin Assignments
- Switch Assignments
- Input Specifications
- Input Filtering
- Output Specifications

### Hardware Specifications

#### *Environmental Specifications*

Ambient Operating Temperature .....	0 to +50 degrees C
Storage Temperature .....	-20 to +70 degrees C
Humidity .....	0 to 90% non-condensing

#### *Mechanical Specification*

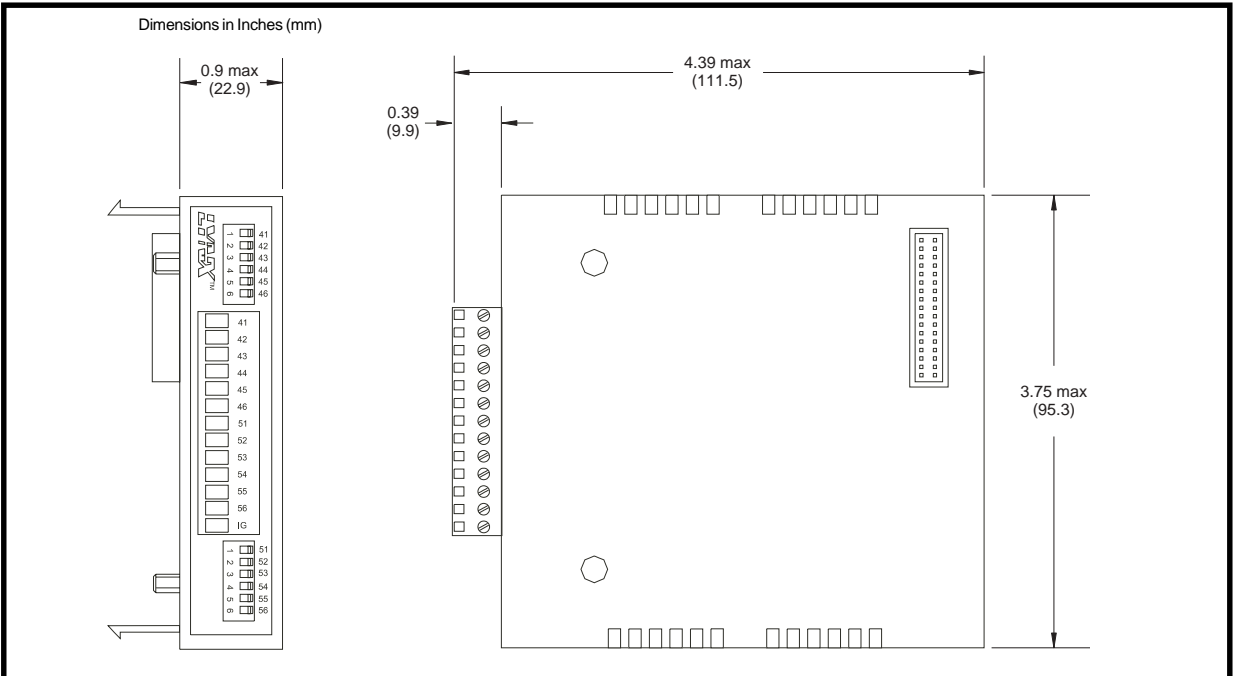

*Figure 9.1: LYNX Isolated I/O Module Dimensions*

## Connection Overview

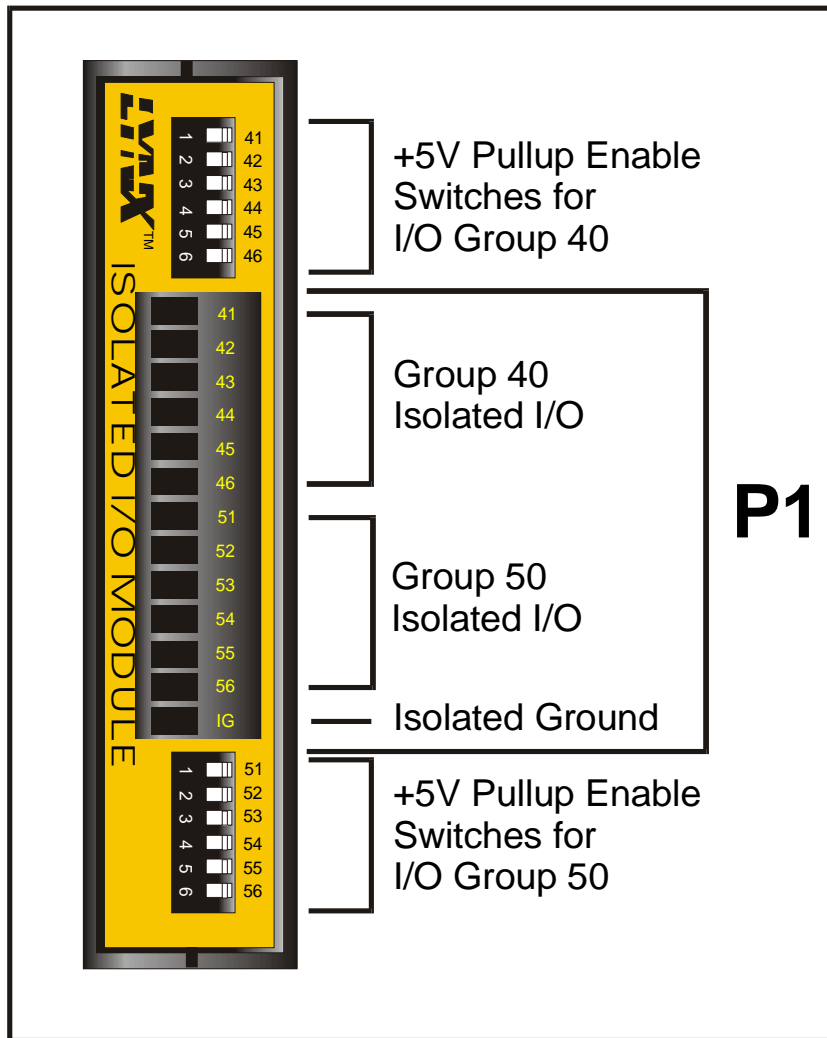

Figure 9.2: Isolated Digital I/O Module Connection Overview

## Pin Assignments And Description

P1 - 13 Position Removeable Terminal Connector: Isolated Digital I/O		
Pin #	Function	Description
1 - 8	I/O Group 40 Lines 41 - 46	Signals are individually programmable as inputs or outputs (see description of the <a href="#">IOS command</a> in the <a href="#">Part 3: Software Reference</a> of this manual). Inputs are CMOS logic level compatible and can accept inputs to 24 volts. Noise rejection is available via digital filtering. Outputs are open drain. I/Os each have individually switchable 7.5 Kohm pull up resistors to 5VDC. Outputs can switch inductive, resistive or incandescent loads. Refer to <a href="#">Section 6: Configuring the Digital I/O</a> for usage and specifications.
7 - 12	I/O Group 50 Lines 51 - 56	See description above.
13	Isolated I/O Ground	Isolated common signal return for groups 40 and 50 I/O. Isolated from the power and communication grounds.

Table 9.1: Isolated Digital I/O Module P1 Connector Pin Configuration

# Switch Assignments And Description

Group 40 I/O Pull-Up Switches: Can Be Changed at any Time, Usable for Exercising Inputs		
Switch #	Function	Description
1 - 6	Individual Switches for I/O Group 40 Pull-Ups.	When this switch is on, the I/O is pulled up through an internal 7.5 Kohm resistor to 5VDC. Can be used to simulate the activation of an input while testing system software..

**Table 9.2: Isolated I/O Module Group 40 I/O Pull-up Switches**

Group 50 I/O Pull-Up Switches: Can Be Changed at any Time, Usable for Exercising Inputs		
Switch #	Function	Description
1 - 6	Individual Switches for I/O Group 50 Pull-Ups.	When this switch is on, the I/O is pulled up through an internal 7.5 Kohm resistor to 5VDC. Can be used to simulate the activation of an input while testing system software..

**Table 9.3: Isolated I/O Module Group 50 I/O Pull-up Switches**

# Input Specifications

Isolated I/O Input Specifications	
Voltage Range	0 to 28 VDC (Transient Protected to 60 Volts)
Low Level	< 1.5V
High Level	> 3.5V
Open Circuit Input Voltage	Pull-Up Switch ON = 4.5V Pull-Up Switch OFF = 0V

**Table 9.4: Isolated I/O Module Input Specifications**

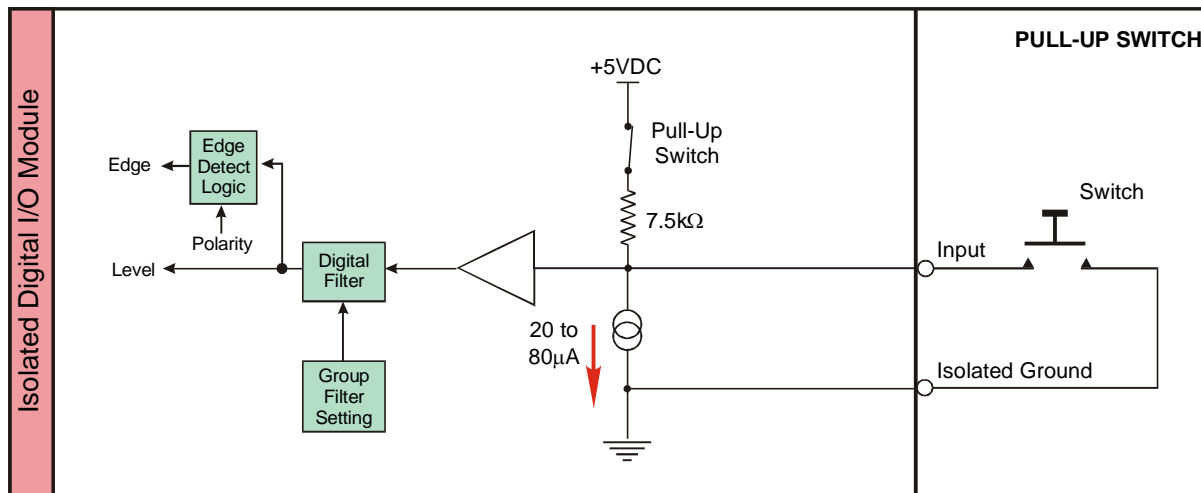

**Figure 9.3: LYNX Isolated I/O Input Equivalent Circuit**

# Input Filtering

User definable Digital filtering makes the LYNX well suited for noisy industrial environments. The filter setting is software selectable using the *IOF Variable* with a minimum guaranteed detectable pulse width of 18 microseconds to 2.3 milliseconds.

The table at right illustrates the IOF settings.

IOF Filter Settings for the General Purpose Isolated I/O IOF=<num> (<num> = 0-7)		
Filter Setting	Cutoff Frequency	Minimum Detectable Pulse Width
0	27.5 kHz	18 microseconds
1	13.7 kHz	36 microseconds
2	6.89 kHz	73 microseconds
3	3.44 kHz	145 microseconds
4	1.72 kHz	290 microseconds
5	860 Hz	581 microseconds
6	430 Hz	1.162 milliseconds
7 (default)	215 Hz	2.323 milliseconds

Table 9.5: Digital Filter Settings for the Isolated I/O

# Output Specifications

Isolated I/O Input Specifications	
Load Supply Voltage	28 VDC Maximum
FET On Resistance	2Ω Maximum (Tj = 125°C)
Continuous Sink Current	350mA Maximum Each Output (Ta = 25°C)
Maximum Group Sink	1.5A (Thermally Limited)
Open Circuit Output Voltage	Pull-up Switch ON = 4.5V Pull-up Switch OFF = 0V

Table 9.6: Digital Filter Settings for the Isolated I/O

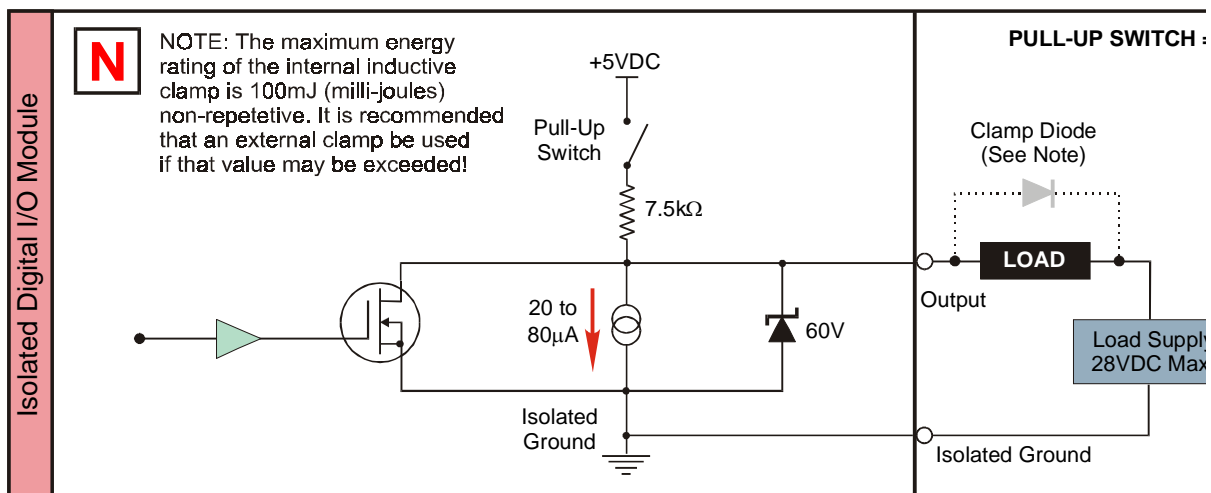

Figure 9.4: LYNX Isolated I/O Output Equivalent Circuit

# Section 10

## The Differential Digital I/O Module

### Section Overview

A LYNX system may contain an optional Differential I/O Module (IMS Part# LX-DD100-000) which provides six (6) high speed differential I/Os. These I/Os can be used as clock inputs or outputs or general purpose I/O. Along with the differential motion I/Os (P1, pins 1 – 4) of the LYNX Control Module, these I/O make up the Group 1 signal set. Each signal pair is a 0 to 5VDC input or output. When used as an input or an output a single ended or differential configuration is accommodated.

- Hardware Specifications
  - Environmental Specifications
  - Mechanical Specifications
  - Power Requirements
- Pin Assignments
- Input Specifications
- Input Filtering
- Output Specifications

### Hardware Specifications

#### Environmental Specification

Ambient Operating Temperature ..... 0 to 50 degrees C  
 Storage Temperature ..... -20 to 70 degrees C  
 Humidity ..... 0 to 90% non-condensing

#### Mechanical Specification

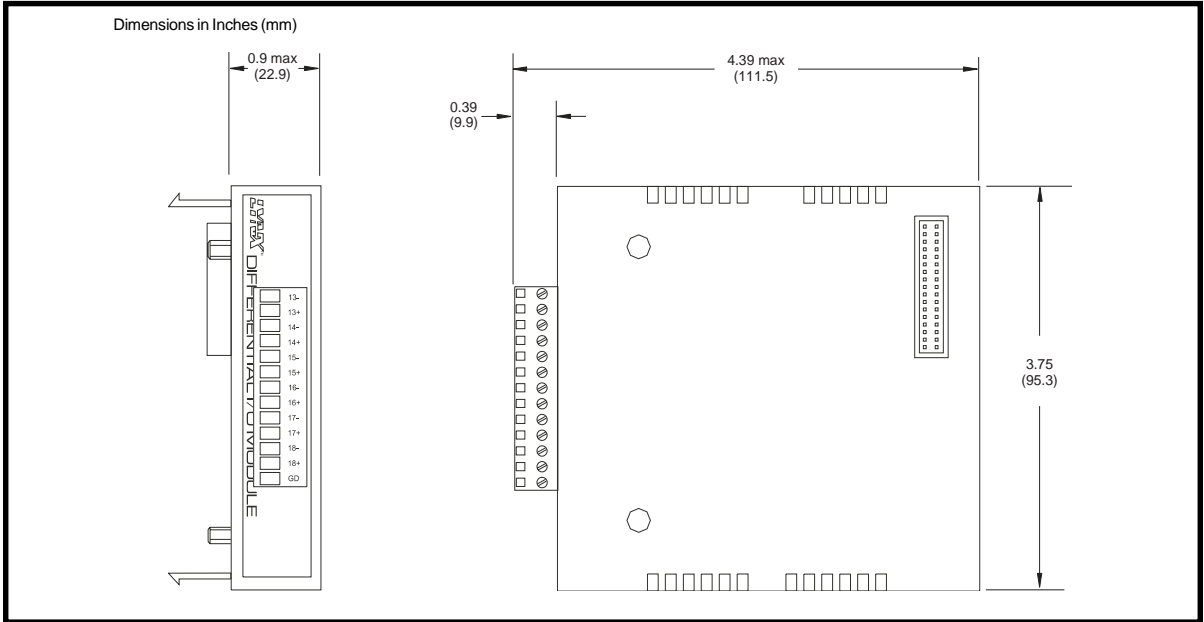

Figure 10.1 : LYNX Differential I/O Module Dimensions

## Connection Overview

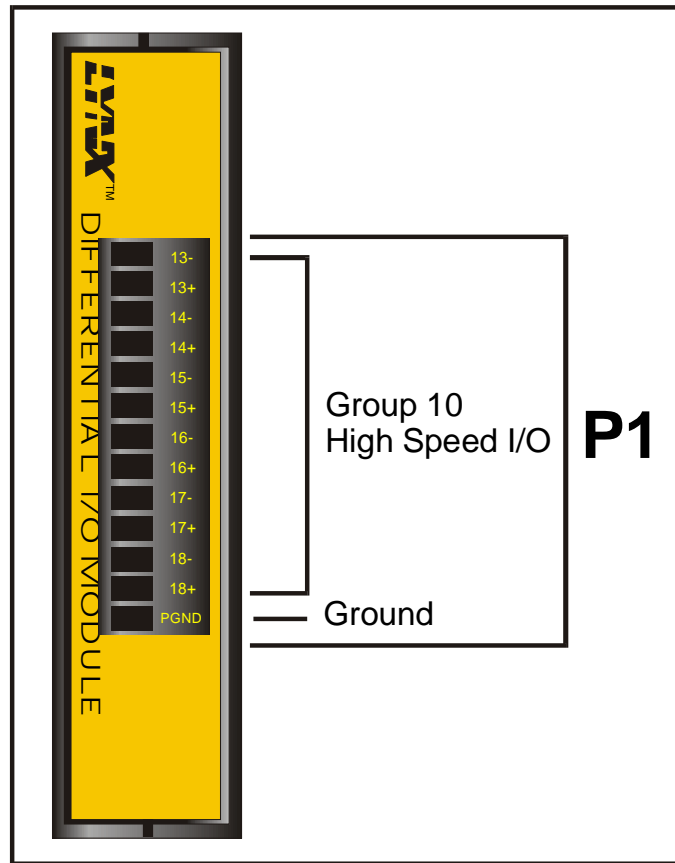

Figure 10.2: High Speed Differential I/O Module Connection Overview

## Power Requirements

Power is supplied through the LYNX Control Module.

High Speed Differential I/O Power Requirement	
Input Voltage to LYNX Control Module	Current Requirement for Module
+5VDC	50mA
+12 VDC	28mA
+48VDC	8mA
+75VDC	5mA

Table 10.1: High Speed Differential I/O Module Power Requirements

## Pin Assignments And Description

P3 - 13 Position Removeable Terminal Connector: High Speed Differential I/O Module		
Pin #	Function	Description
1	I/O 13-	Pins 1 and 2 are the differentially buffered signal for group 10, I/O 13. This channel is configured by means of the <a href="#">IOS Instruction</a> . This channel is fixed as clock #2 and associated with Counter 2 (CTR2). For usage details see <a href="#">Section 6: Configuring the Digital I/O</a> .
2	I/O 13+	See description above.
3	I/O 14-	Pins 3 and 4 are the differentially buffered signal for group 10, I/O 14. This channel is configured by means of the <a href="#">IOS Instruction</a> . This channel is fixed as clock #2 and associated with Counter 2 (CTR2). For usage details see <a href="#">Section 6: Configuring the Digital I/O</a> .
4	I/O 14+	See description above.
5	I/O 15-	Pins 5 and 6 are the differentially buffered signal for group 10, I/O 15. This channel is configured by means of the <a href="#">IOS Instruction</a> . This channel is fixed as clock #3 and associated with Counter 3 (CTR3). For usage details see <a href="#">Section 6: Configuring the Digital I/O</a> .
6	I/O 15+	See description above.
7	I/O 16-	Pins 7 and 8 are the differentially buffered signal for group 10, I/O 16. This channel is configured by means of the <a href="#">IOS Instruction</a> . This channel is fixed as clock #3 and associated with Counter 3 (CTR3). For usage details see <a href="#">Section 6: Configuring the Digital I/O</a> .
8	I/O 16+	See description above.
9	I/O 17-	Pins 9 and 10 are the differentially buffered signal for group 10, I/O 17. This channel is configured by means of the <a href="#">IOS Instruction</a> . This Channel may be configured as a high speed input or output. As an output it is a 1MHz reference clock. I/O 17 and 18 are not associated to a counter. For usage details see <a href="#">Section 6: Configuring the Digital I/O</a> .
10	I/O 17+	See description above.
11	I/O 18-	Pins 11 and 12 are the differentially buffered signal for group 10, I/O 18. This channel is configured by means of the <a href="#">IOS Instruction</a> . This Channel may be configured as a high speed input or output. As an output it is a 10MHz reference clock. I/O 17 and 18 are not associated to a counter. For usage details see <a href="#">Section 6: Configuring the Digital I/O</a> .
12	I/O 18+	See description above.
13	PGND	Non-isolated ground. Common with the LYNX Control Module power ground.

**Table 10.2: High Speed Differential I/O Module Pin Configuration**

## Input Specifications

High Speed Differential I/O Input Specifications	
Differential Input Threshold	-0.2V to +0.2V
Input Hysteresis	60mV Typical
Input Common Mode Range	-6V to +6V
Maximum Group Sink	1.5A (Thermally Limited)
Open Circuit Input Voltage + Input	4.3V
Open Circuit Input Voltage - Input	1.4V

**Table 10.3: High Speed Differential I/O Module Input Specifications**

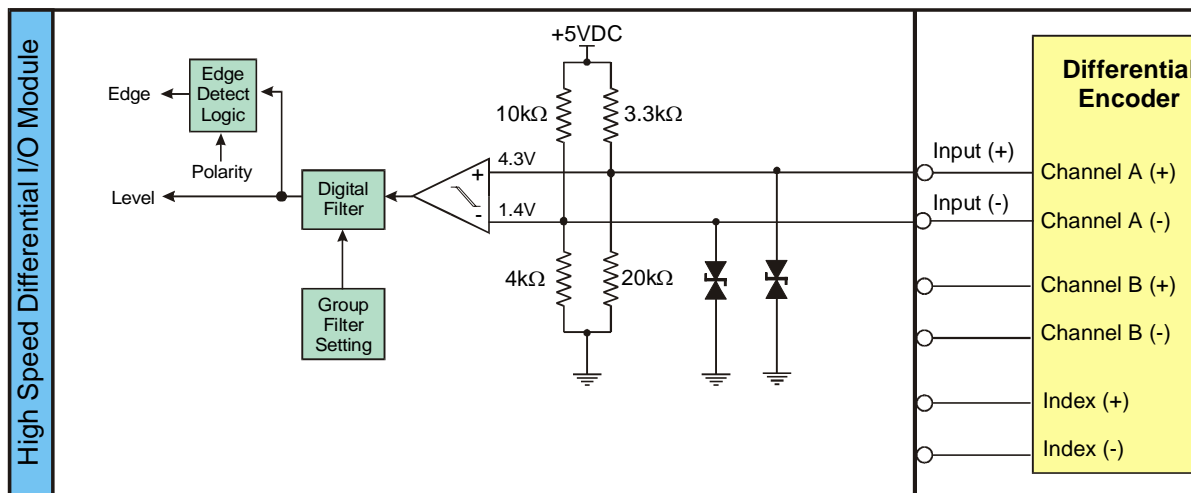

Figure 10.3: LYNX Differential I/O Input Equivalent Circuit

## Input Filtering

User definable Digital filtering makes the LYNX well suited for noisy industrial environments. The filter setting is software selectable using the [IOF Variable](#) with a minimum guaranteed detectable pulse width of 18 microseconds to 2.3 milliseconds.

The table below illustrates the IOF settings.

IOF Filter Settings for the High Speed Differential I/O IOF=<num> (<num> = 0-7)		
Filter Setting	Cutoff Frequency	Minimum Detectable Pulse Width
0 (default)	5.00 MHz	100 nanoseconds
1	2.50 MHz	200 nanoseconds
2	1.25 MHz	400 nanoseconds
3	625 kHz	800 nanoseconds
4	313 kHz	1.6 microseconds
5	156 kHz	3.2 microseconds
6	78.1 kHz	6.4 microseconds
7	39.1 kHz	12.8 microseconds

Table 10.4: Digital Filter Settings for the Differential I/O

# Output Specifications

High Speed Differential I/O Output Specifications		
	No Load	6mA Load
Output Voltage - Logic 0	0.5V	0.8V
Output Voltage - Logic 1	4.5V	4.2V
Short Circuit Current	250mA Max.	

*Table 10.5: LYNX Differential I/O Output Specifications*

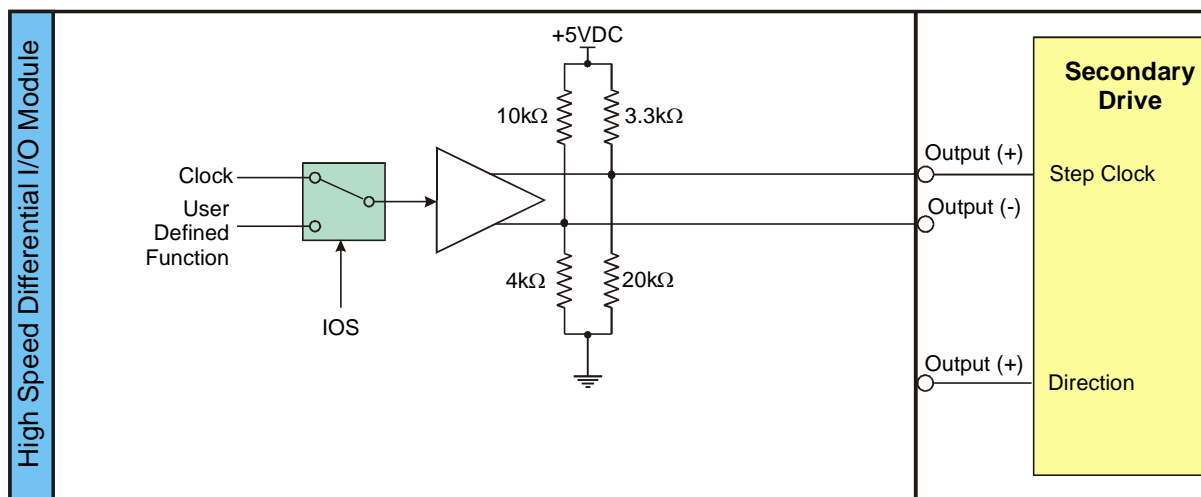

*Figure 10.4: LYNX Differential I/O Output Equivalent Circuit*

*Intentionally Left Blank*