

IMS™

INTELLIGENT MOTION SYSTEMS, INC.

Excellence in Motion™



PANTHER LI & PANTHER LE

**MINIATURE HIGH PERFORMANCE
MICROSTEPPER DRIVER, INDEXER & POWER SUPPLY**

HARDWARE REFERENCE MANUAL

The information in this book has been carefully checked and is believed to be accurate; however, no responsibility is assumed for inaccuracies.

*Intelligent Motion Systems reserves the right to make changes without further notice to any products herein to improve reliability, function or design. Intelligent Motion Systems does not assume any liability arising out of the application or use of any product or circuit described herein; neither does it convey any license under its patent rights nor the rights of others. Intelligent Motion Systems and **IMS** are trademarks of Intelligent Motion Systems, Incorporated.*

Intelligent Motion Systems, Inc. general policy does not recommend the use of its products in life support applications wherein a failure or malfunction of the product may directly threaten life or injury. Per Intelligent Motion Systems Terms and Conditions of Sales, the user of Intelligent Motion Systems products in life support applications assumes all risks of such use and indemnifies Intelligent Motion Systems against all damages.

Table of Contents

1 INTRODUCTION	1
2 PIN ASSIGNMENTS	2
3 PIN DESCRIPTION	3
4 ABSOLUTE MAXIMUM RATING	4
5 ELECTRICAL SPECIFICATIONS	5
6 MECHANICAL SPECIFICATIONS	6
7 THERMAL SPECIFICATIONS	7
8 OUTPUT CURRENT	8
8.1 DETERMINING OUTPUT CURRENT	8
8.2 SETTING OUTPUT CURRENT	9
9 ENCODER INTERFACE	9
10 MOTOR	10
10.1 MOTOR SELECTION	10
10.2 CONNECTING THE MOTOR	11
11 CONNECTING POWER	12
11.1 FUSE	12
12 OPTICALLY ISOLATED INPUTS (Limit A, Limit B, Home, Party)	13
13 GENERAL PURPOSE INPUTS AND OUTPUTS	14
14 DEDICATED INPUTS	15
15 MOVING OUTPUT	15
16 FAULT PROTECTION	16
17 RS232 INTERCONNECT	16
18 PARTY LINE OPERATION	17
18.1 PARTY LINE CONNECTION USING RS-232 OPTION	17
19 +5V DC OUTPUT	18
20 OPTIONS/ACCESSORIES	18
22 WARRANTY	19

LIST of TABLES

Table 1	ABSOLUTE MAXIMUM RATINGS	4
Table 2	ELECTRICAL SPECIFICATIONS	5
Table 3	THERMAL SPECIFICATIONS	7
Table 4	POWER SUPPLY SPECIFICATIONS	12
Table 5	OPTICALLY ISOLATED INPUTS	13

LIST of FIGURES

Fig. 1	MACHANICAL OUTLINE	6
Fig. 2	ENCODER INTERFACE.....	9
Fig. 3	MOTOR CONNECTIONS	11
Fig. 4	ISOLATED INPUTS.....	13
Fig. 5	GENERAL PURPOSE INPUTS AND OUTPUTS.....	14
FIG. 6	DEDICATED INPUTS	15

INTRODUCTION

The PANTHER LI & LE with Integral driver, Indexer, power supply, and encoder feedback are complete high performance microstepping systems in a small, self contained package. The Panther LI & LE use advanced surface mount and ASIC technology for unmatched performance, reliability, and value.

The heart of the Panther LI & LE is our IM483I & IM483IE miniature OEM microstepping driver with on board Intelligent Indexer.

The PANTHER LI & LE's indexer delivers superior results by integrating standard hardware with a technology called Variable Resolution Microstep Control. At low shaft speeds, the indexer produces high resolution microstep positioning for silent, resonance-free operation. As shaft speed increases, the output step resolution is expanded using "on-motor-pole" synchronization. At the completion of a move, the target micro position is trimmed to 1/100 of a step to achieve and maintain precise positioning.

Combined with the IM483I & IM483IE is a highly efficient switching power supply that run the drivers at peak performance will reducing package weight and size.

Incorporated into the PANTHER LI & LE drivers are circuits that minimize ripple current while maintaining a 20KHz chopping rate. This prevents additional motor heating that is common with drivers requiring higher chopping rates. Now low inductance step motors can be used to improve high speed performance and peak system efficiency.

The results of this unique driver/indexer/power supply combination is a cost effective, off the shelf solution, that can provide designers with a powerful and versatile unit that is unmatched in today's industry.

FEATURES

- INTEGRAL INDEXER, DRIVER, POWER SUPPLY, AND ENCODER FEEDBACK
- EXTREMELY COMPACT 2.3 X 3.9 X 4.4
- LOW COST
- SHORT CIRCUIT AND OVER TEMPERATURE PROTECTION
- FAULT AND POWER INDICATORS
- HIGH OUTPUT CURRENT
(3 AMPS RMS, 4 AMPS PEAK)
- ADVANCED SURFACE MOUNT & ASIC TECHNOLOGY
- OPTIONAL SIDE OR RACK MOUNTING
- FIXED OR VARIABLE STEP RESOLUTION
- 1/100 STEP COMMAND RESOLUTION
- 1/256 STEP MOTOR RESOLUTION
- PROGRAMMABLE ACCEL & DECEL RAMPS
- PROGRAMMABLE MOTOR RUN AND HOLD CURRENTS
- RS-422 PARTY LINE OPERATION (OPTIONAL RS232 COMMUNICATION)
- 2K BYTES OF NON-VOLATILE MEMORY FOR PROGRAM STORAGE
- 6 BUFFERED USER I/O PORTS
- OPTICALLY ISOLATED HOME AND LIMIT SWITCH INPUTS
- JOG INPUTS
- GO AND SOFT STOP INPUTS
- OPTIONAL *WINDOWS BASED PROGRAMMING SOFTWARE
- MOTOR SPEEDS TO 6,000 RPMs
- PROGRAMMABLE TRIP POINTS
- OVER 50 MOTION CONTROL COMMANDS

*Windows is a registered trademark of the MICROSOFT CORP.

PATENTS PENDING

PIN ASSIGNMENTS

Connector P1

PIN #	FUNCTION
1	Phase A
2	Phase \bar{A}
3	Phase B
4	Phase \bar{B}
5	AC Input: Neutral*
6	AC Input: Line*

Connector P2

PIN #	FUNCTION
1	TX - (RS-422/485)
2	TX + (RS-422/485)
3	RX - (RS-422/485)
4	RX + (RS-422/485)
5	Limit A
6	Party
7	Limit B
8	Home
9	Opto Supply Voltage
10	Fault
11	Ground
12	Go
13	Soft Stop

* WARNING !! It is important to follow the correct polarity of the AC input to prevent device damage.

†Connector P4

*PIN #	FUNCTION
2	Transmit Data (RS-232)
3	Receive Data (RS-232)
5	GROUND (RS-232)
9	+5VDC (for optional Hand Held Terminal)

*Pins not shown are not used.

†Connector supplied with optional RS232 Interface.

Connector P3

PIN #	FUNCTION
1	Input 3
2	Input 2
3	Input 1
4	+5V DC Output
5	Output 3
6	Output 2
7	Output 1
8	Moving
9	Jog +
10	Jog -
†11	Index - (LE models only with differential option)
†12	index (LE models only) (index + for differential option)
†13	Channel A - (LE models only with differential option)
†14	Channel A (LE models only) (Channel A+ differential option)
†15	Channel B - (LE models only with differential option)
†16	Channel B (LE models only) (Channel B+ differential option)

†For LI model - these inputs are not used.

PIN DESCRIPTION

Connector P2

PIN # PIN NAME

FUNCTION

1	TX-	RS422/485 Transmit -, (data out from indexer).
2	TX +	RS422/485 Transmit +, (data out from indexer).
3	RX-	RS422/485 Receive -, (data in to indexer).
4	RX +	RS422/485 Receive +, (data in to indexer).
5	Limit A	Optically isolated, active low limit switch Input for "+" direction. (See "I" command).
6	Party	Optically isolated party mode select pin: 0 = Party, 1 (Floating) = Single.
7	Limit B	Optically isolated, active low limit switch input for "-" direction. (See "I" command)
8	Home	Optically isolated, active low Home switch input. (See "F" command).
9	Opto Supply	Vdc + bias for input opto couplers. Internal current limiting resistors for +5vdc are supplied. User must connect resistors in series with optically isolated input signals for voltages greater than 5vdc (See figure 4).
10	Fault	Open collector output indicating driver fault condition. This output will be active when the IM2000 detects an internal fault such as overcurrent or phase short. This output must be pulled high externally. A reset or power down is required to clear the fault condition.
11	Ground	Logic Supply Ground connection.
12	GO	Active low level input to execute a program stored in NVM. Program execution begins at location 0 in memory. Internally pulled up to +5vdc through a 10k resistor. Once executing, the GO input is ignored until the program completes or an Abort/Stop is first executed.
13	Soft Stop	Active low input to stop indexing using deceleration ramp. Internally pulled up to +5vdc through a 10k resistor.

Connector P3

PIN # PIN NAME

FUNCTION

1	Input 3	User controlled input #3, (active low). Internally pulled up to +5vdc through a 10K resistor. (See "A" command).
2	Input 2	User controlled input #2, (active low). Internally pulled up to +5vdc through a 10K resistor. (See "A" command).
3	Input 1	User controlled input #1, (active low). Internally pulled up to +5vdc through a 10K resistor. (See "A" command).
4	+5VDC	Logic supply output for Encoder power.
5	Output 3	User controlled output #3 (active low). This is an open collector output with an internal 10k pullup resistor. (See "A" command).
6	Output 2	User controlled output #2 (active low). This is an open collector output with an internal 10k pullup resistor. (See "A" command).
7	Output 1	User controlled output #1 (active low). This is an open collector output with an internal 10k pullup resistor. (See "A" command).
8	Moving	NON-BUFFERED output, low when indexing is in progress. High when not moving.
9	Jog +	Active low Jog input for "+" direction. Internally pulled up to +5vdc through a 10k resistor.
10	Jog -	Active low Jog input for "-" direction. Internally pulled up to +5vdc through a 10k resistor.
11	Index -	Differential Encoder Index Mark - input.
12	Index +	Encoder Index Mark input. Internally pulled up to +5vdc through a 10k resistor. (Differential Encoder Index Mark + input.)
13	Channel A -	Differential Encoder Channel A - input.
14	Channel A +	Encoder Channel A input. Internally pulled up to +5vdc through a 10k resistor. (Differential Encoder Channel A + input.)
15	Channel B -	Differential Encoder Channel B - input.
16	Channel B +	Encoder Channel B input. Internally pulled up to +5vdc through a 10k resistor. (Differential Encoder Channel B + input.)

ABSOLUTE MAXIMUM RATING

Table 1

INPUT VOLTAGE	90 to 130 VAC
OUTPUT CURRENT.....	5 AMPS PEAK
HOUSING TEMPERATURE.....	+ 60 C
STORAGE TEMPERATURE.....	-40 TO +125 C
LOGIC INPUT CURRENT (ISOLATED INPUTS).....	15 mA
LOGIC OUTPUT CURRENT	25mA
POWER DISSIPATION (Logic Outputs)	450 mW
INPUT VOLTAGE (Dedicated Logic Inputs)	-1.5 to +18 V

ELECTRICAL SPECIFICATIONS

Table 2

TA = 25 C, V = 120 VAC

	TEST CONDITION	MIN	TYP	MAX	UNITS
PHASE OUTPUT CURRENT.....	RMS.....	0.4		3	A
PHASE OUTPUT CURRENT.....	PEAK.....			4	A
ACTIVE POWER DISSIPATION.....	IOUT = 3 AMPS RMS.....			12	W
INPUT FORWARD CURRENT.....	ISOLATED INPUTS.....		7.0	15	mA
INPUT FORWARD VOLTAGE.....	ISOLATED INPUTS.....		1.5	1.7	V
INPUT REVERSE BREAKDOWN VOLTAGE.....	ISOLATED INPUTS.....		5		V
INPUT VOLTAGE.....	DEDICATED LOGIC INPUTS.....	0		15	V
INPUT VOLTAGE.....	GENERAL PURPOSE INPUTS.....	0		5	V
OUTPUT CURRENT.....	FAULT OUTPUT.....			25	mA
COLLECTOR-EMITTER VOLTAGE.....	FAULT OUTPUT.....			140	V
COLLECTOR-EMITTER SATURATION VOLTAGE.....	FAULT OUTPUT.....			0.2	V

Ics = 25 mA DC

NOTE: The aluminum housing is electrically isolated

MECHANICAL SPECIFICATIONS

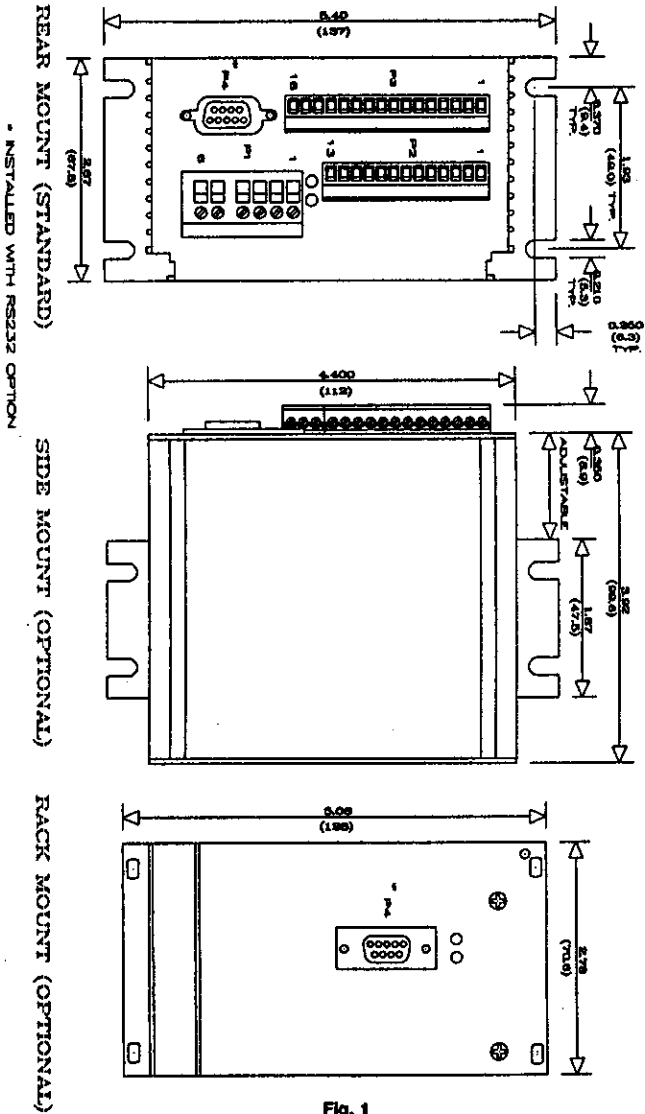

Fig. 1

THERMAL SPECIFICATIONS

Table 3

OPERATING TEMPERATURE	0 TO +50 C
STORAGE TEMPERATURE	-40 TO +125 C
HOUSING TEMPERATURE (MAX)	+60 C

OUTPUT CURRENT

DETERMINING OUTPUT CURRENT

The OUTPUT CURRENT for motor used for MICROSTEPPING is determined differently from that of a HALF/FULL STEP driver.

In the PANTHER LI & LE, a sine/cosine output function is used in rotating the motor. Therefore the output current of the specified motor is equal to the RMS current of the driver.

The DIGITAL POTENTIOMETER used to set the output current of the PANTHER LI & LE sets the PEAK output current of the sine/cosine waves. Therefore the specified motor current (which is the RMS value) should be multiplied by 1.4 in order to determine the PEAK value to which the PANTHER LI & LE will be set.

EXAMPLE:

IMS motor number HM200-2232-190 A8 wired in parallel has a specified PHASE CURRENT of 2.7 amps.

Therefore $2.7 \times 1.4 = 3.78$ amps

Note: Stepper motors can be configured as 4, 6, or 8 leads. Each configuration requires different currents. shown below are the different lead configurations and the procedures to determine their output current

4 Lead Motors: Use specified motor current to determine the current adjustment resistor value.

6 Lead Motors: 1) When configuring a 6 lead motor in a half coil configuration (I.e. connected from one end of the coil to the center tap (higher speed configuration)) use the specified per phase (or unipolar) current rating to determine the current adjustment resistor value.

2) When configuring the motor so the entire coil is used (I.e. connected from end to end with the center tap floating (higher torque configuration)) multiply the per phase (or unipolar) current rating by 0.7. Use this result to determine the current adjustment resistor value.

8 Lead Motors: **SERIES CONNECTION** When configuring the motor windings in series, multiply the per phase (or unipolar) current rating by 0.7. Use this result to determine the current adjustment resistor value.

PARALLEL CONNECTION When configuring the motor windings in parallel, multiply the per phase (or unipolar) current rating by 1.4. Use this result to determine the current adjustment resistor value.

Note: After the current has been determined, according to the motor connections above, follow the procedure Determining Output Current above to find the PEAK current value.

WARNING! Although stepping motors will run hot when configured correctly, damage may occur to the motor if a higher than specified current is used. Most specified motor currents are maximum values. Care should be taken when exceeding these ratings.

SETTING OUTPUT CURRENT

The OUTPUT CURRENT for both Run and Hold are set using an on board digital potentiometer. Refer to the software reference manual for further information.

ENCODER INTERFACE

An encoder with TTL level outputs is required to interface with the PANTHER LE. On board 10K pullups are provided so that encoders with open collector outputs may be used. Figure 2 shows a typical encoder interface.

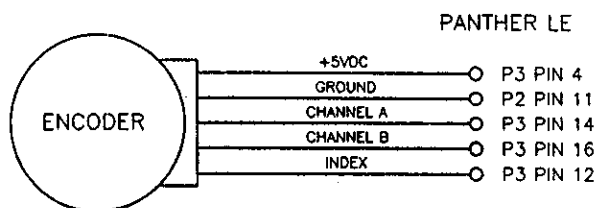

Fig. 2

Figure 2A shows a typical encoder interface for the Panther LE - DE with differential interface.

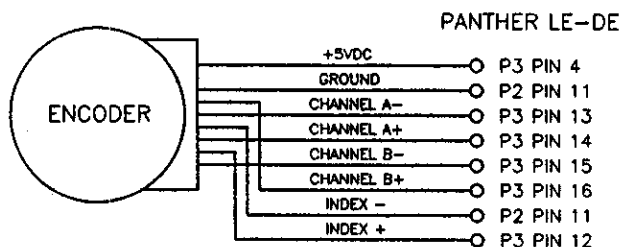

Fig. 2A

MOTOR SELECTION

The PANTHER LJ & LE are Bipolar drivers which work equally well with both Bipolar and Unipolar motors, (i.e. 8 and 4 lead motors and 6 lead center tapped motors (see section 10.2, Connecting the Motor)).

To maintain a given set motor current, the PANTHER LJ & LE chops the voltage using a constant chopping frequency and a varying duty cycle. Duty cycles that exceed 50% can cause unstable chopping. This characteristic is directly related to the motor's winding resistance. To avoid this situation, it is necessary to choose a motor with a low winding resistance. The lower the winding resistance (hence lower winding inductance) the higher the step rate.

Since the PANTHER LJ & LE are constant current sources, it is not necessary to use a motor that is rated at the same voltage as the supply voltage. What is important is that the PANTHER LJ & LE are set to the motor's rated current.

The higher the voltage used the faster the current can flow through the motor coils. This in turn means a higher step rate. Care should be taken not to exceed the maximum voltage of the driver.

Therefore in choosing a motor for a system design, the best performance for a specified torque is a motor with the lowest possible winding resistance used in conjunction with the highest possible driver voltage.

CONNECTING THE MOTOR

Phase A of the Stepping Motor is connected between pins 1 and 2 on connector P1. Phase B of the Stepping Motor is connected between pins 3 and 4 on connector P1. The following drawings illustrate the connection of 4, 6, and 8 Lead Stepping Motors to the PANTHER LI & LE Drivers.

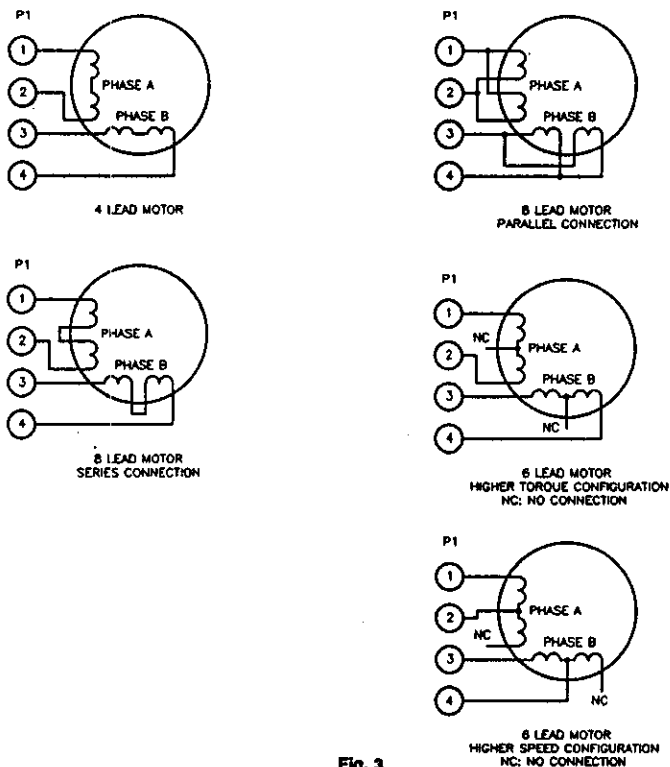

Fig. 3

NOTE: The physical direction of the motor with respect to the direction input will depend on the connection of the motor windings. To reverse the direction of the motor with respect to the direction input, switch the wires on phase A or phase B outputs.

Warning!! Do not connect or disconnect motor wires while power is applied!!

When connecting the motor leads, make sure each lead is tightly connected. Tug on each motor lead for proper connection !!

CONNECTING POWER

Pins 5 and 6 on connector P1 are used to connect the AC Power to the PANTHER LI & LE. The wire size used to connect the power source to the driver should be at least 18 gauge. The power supply requirements are as follows:

* **WARNING !!** It is important to follow the correct polarity of the AC input to prevent device damage.

Table 4

POWER SUPPLY SPECIFICATIONS

AC INPUT.....	90 to 128 VAC
* Current	Amps (MAX)

* THE CURRENT NEEDED IS DEPENDENT ON THE SUPPLY VOLTAGE, MOTOR SELECTION, AND LOAD.

Warning!! Do not connect or disconnect motor wires while power is applied!!

FUSE

The Panther LI & LE contain a fuse that is mounted inside the housing.

To replace the fuse the front panel must be removed along with the four allen head screws on the side of the housing.

After removal of the cover and the side screws, slide the enclosed printed circuit board assembly from the housing.

The fuse is located just behind the P1 connector. It is only necessary to remove the board assembly approximately 2 inches to access the fuse.

NOTE: When reinstalling the assembly, take care not to destroy the thermal pad attached to the driver module.

Fuse Type: 5mm, 250 volt, 2 amp slow blow

NOTE: Under normal operating conditions it should not be necessary to replace the internal fuse. If the unit operates incorrectly or there is no power indicator present when the unit is powered, the unit should be returned to the factory for service.

OPTICALLY ISOLATED INPUTS (Limit A, Limit B, Home, Party)

The following inputs to the PANTHER LI & LE are Optically Isolated.

Table 5

Connector P1

Limit A	Pin 5 on P2
Limit B	Pin 7 on P2
Home.....	Pin 8 on P2
Party.....	Pin 6 on P2

For functional use of these inputs refer to the software reference manual.

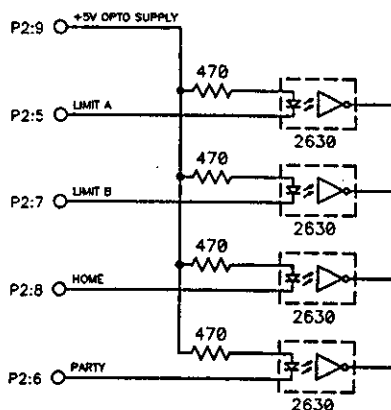

OPTICALLY ISOLATED INPUTS

Fig. 4

The isolated inputs may be powered by a DC voltage other than +5 VDC. In doing so, care should be taken to limit this current, an external resistor should be placed in series with the input pins (5,6,7,8). The value of the resistor should be calculated such that the input current is approximately equal to the value listed in the Electrical Specifications in Table 2.

WARNING! If using a voltage other than +5VDC, the current through the optocoupler must NOT exceed the maximum limit.

GENERAL PURPOSE INPUTS AND OUTPUTS

The PANTHER LI & LE contain 3 general purpose inputs and 3 general purpose outputs. The inputs are TTL compatible and are pulled up via a 10K resistor to +5V on the input. (see Fig below)

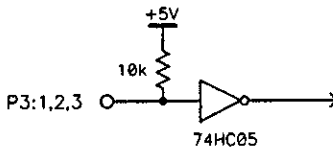

The outputs are TTL compatible open collector type and are also pulled to +5V via a 10K resistor. (see Fig. below).

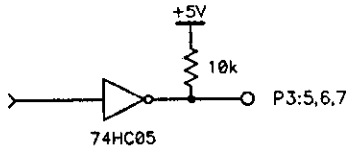

Fig. 5

For functional use of these inputs and outputs refer to the Software Reference Manual.

DEDICATED INPUTS

The PANTHER LJ & LE contain 4 dedicated inputs: Go, Soft Stop, Jog +, and Jog --. They are capable of handling logic level inputs that range from +5 VDC to +15 VDC. The inputs are pulled up to +5V via a 10K resistor on the inputs (see Fig below).

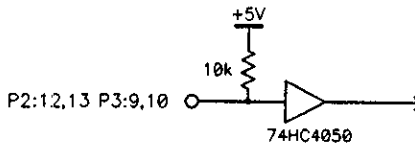

Fig. 6

For functional use of these inputs refer to the Software Reference Manual.

MOVING OUTPUT

The moving output is used to indicate when the motor is in motion. When LOW, the indexer is stepping the motor (in either direction). When HIGH the motor is at rest.

The Moving output is buffered as shown below.

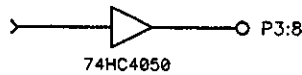

FAULT PROTECTION

The PANTHER LI & LE are internally protected against over temperature and short circuits.

The over temperature protection in the PANTHER LI & LE is built into the power output bridge ICs. This circuit will disable the output if the junction temperature within the IC reaches 150 C. When the temperature has fallen to a safe level the outputs will be reenable.

The short circuit protection consists of PHASE to PHASE, PHASE to GROUND, and +V to PHASE.

If a short circuit is detected by the PANTHER LI & LE, the outputs will be disabled and can not be re-enabled without resetting or powering down the driver. At the same time the open collector FAULT output is turned on and the FAULT LED is activated.

This Fault output is non-isolated and has the ability to sustain the maximum driver Cutage. It is capable of sinking up to 25mA and is used to drive the fault LED. Approximately 10 mA is used to drive the fault LED.

RS232 INTERCONNECT

The optional RS232 communication interface to the Panther LI & LE, utilizes a female 9 pin subminiature D connector.

The cable interface diagram is shown below:

Panther LI & LE	Computer
TD 2	2 RD
RD 3	3 TD
GND 5	5 GND
+5VDC 9	(for optional Hand Held Terminal)

PARTY LINE OPERATION

The PANTHER LJ & LE can operate as stand alone units or they can be configured to communicate over a party line which responds to a unique address. Up to 32 units can be linked together on one line (using the RS422 differential interface).

To communicate over the party line, the unit must first be assigned an address. This assignment takes place via the Serial Communication line with the PANTHER LJ & LE in a Stand Alone mode (i.e. P2 pin 6 floating).

After an address is assigned, the PANTHER LJ & LE can be tied to the Multi Unit System by enabling the Party Line input (P2 pin 6).

Figure 7 shows a typical Party Line Connection.

For more information on interfacing to the Party Line input, refer to Section 11.

For more information on Assigning Addresses, refer to the Software Reference Manual.

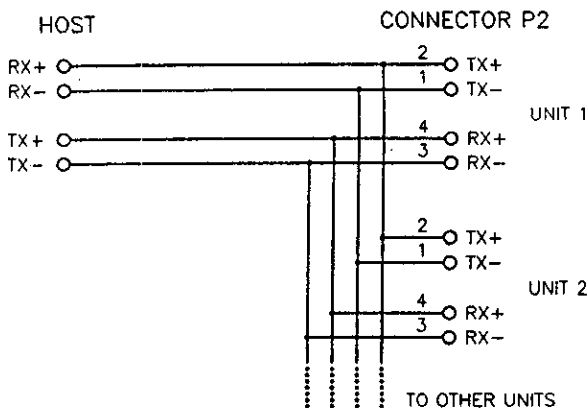

Fig. 7

PARTY LINE CONNECTION USING RS-232 OPTION

When running in Party Line Mode with the RS-232 option, the host communicates with the unit via RS-232 by using the 9 pin D type connector (P4). This unit would then be connected to the other units in the system operating in the party line mode such that all of the TX+'s would be tied together, as well as the TX-, RX+, and RX-, respectively. The address assignment and the communications would be as described in the Party Line Operations above.

+5V DC OUTPUT

The +5V DC output on the PANTHER LJ & LE is intended to drive the encoder feedback device ONLY. This output should NOT be used as a general purpose power supply. When using this supply care should be taken not to inject noise back into the driver. An increase in case temperature may also occur due to the increase in current through the linear regulator.

OPTIONS/ACCESSORIES

Description	Part Number
Built in RS232 to RS422/485 converter	Panther LJ2, LE2
GUI Controller Software (Requires *Windows V3.0 or greater)	QuickSTEP™
Side Mounting Bracket Kit	PL-SM
Rack Mounting Option	-RM
Differential Encoder Option	-DE

*Windows is a registered trademark of the MICROSOFT CORP.

WARRANTY

TWENTY-FOUR (24) MONTH LIMITED WARRANTY

Intelligent Motion Systems, Inc. ("IMS"), warrants only to the purchaser of the Product from IMS (the "Customer") that the product purchased from IMS (the "Product") will be free from defects in materials and workmanship under the normal use and service for which the Product was designed for a period of 24 months from the date of purchase of the Product by the Customer. Customer's exclusive remedy under this Limited Warranty shall be the repair or replacement, at Company's sole option, of the Product, or any part of the Product, determined by IMS to be defective. In order to exercise its warranty rights, Customer must notify Company in accordance with the instructions described under the heading "Obtaining Warranty Service."

This Limited Warranty does not extend to any Product damaged by reason of alteration, accident, abuse, neglect or misuse or improper or inadequate handling; improper or inadequate wiring utilized or installed in connection with the Product; installation, operation or use of the Product not made in strict accordance with the specifications and written instructions provided by IMS; use of the Product for any purpose other than those for which it was designed; ordinary wear and tear; disasters or Acts of God; unauthorized attachments, alterations or modifications to the Product; the misuse or failure of any item or equipment connected to the Product not supplied by IMS; improper maintenance or repair of the Product; or any other reason or event not caused by IMS.

IMS HEREBY DISCLAIMS ALL OTHER WARRANTIES, WHETHER WRITTEN OR ORAL, EXPRESS OR IMPLIED BY LAW OR OTHERWISE, INCLUDING WITHOUT LIMITATION, **ANY WARRANTIES OF MERCHANTABILITY OR FITNESS FOR ANY PARTICULAR PURPOSE**. CUSTOMER'S SOLE REMEDY FOR ANY DEFECTIVE PRODUCT WILL BE AS STATED ABOVE, AND IN NO EVENT WILL THE IMS BE LIABLE FOR INCIDENTAL, CONSEQUENTIAL, SPECIAL OR INDIRECT DAMAGES IN CONNECTION WITH THE PRODUCT.

This Limited Warranty shall be void if the Customer fails to comply with all of the terms set forth in this Limited Warranty. This Limited Warranty is the sole warranty offered by IMS with respect to the Product. IMS does not assume any other liability in connection with the sale of the Product. No representative of IMS is authorized to extend this Limited Warranty or to change it in any manner whatsoever. No warranty applies to any party other than the original Customer.

IMS and its directors, officers, employees, subsidiaries and affiliates shall not be liable for any damages arising from any loss of equipment, loss or distortion of data, loss of time, loss or destruction of software or other property, loss of production or profits, overhead costs, claims of third parties, labor or materials, penalties or liquidated damages or punitive damages, whatsoever, whether based upon breach of warranty, breach of contract, negligence, strict liability or any other legal theory, or other losses or expenses incurred by the Customer or any third party.

OBTAINING WARRANTY SERVICE

Warranty service may be obtained by a distributor, if the Product was purchased from IMS by a distributor, or by the Customer directly from IMS, if the Product was purchased directly from IMS. Prior to returning the Product for service, a Returned Material Authorization (RMA) number must be obtained. Complete the form at <http://www.imshome.com/rma.html> after which an RMA Authorization Form with RMA number will then be faxed to you. Any questions, contact IMS Customer Service (860) 295-6102.

Include a copy of the RMA Authorization Form, contact name and address, and any additional notes regarding the Product failure with shipment. Return Product in its original packaging, or packaged so it is protected against electrostatic discharge or physical damage in transit. The RMA number **MUST** appear on the box or packing slip. Send Product to: Intelligent Motion Systems, Inc., 370 N. Main Street, Marlborough, CT 06447.

Customer shall prepay shipping charges for Products returned to IMS for warranty service and IMS shall pay for return of Products to Customer by ground transportation. However, Customer shall pay all shipping charges, duties and taxes for Products returned to IMS from outside the United States.



IMS Driver Manual Addendum

Recommended Wiring

Logic level cables *must not run parallel* to power cables. Power cables will introduce noise into the logic level cables and make your system unreliable.

Logic level cables must be shielded to reduce the chance of EMI induced noise. The shield needs to be grounded at the signal source to AC ground. The other end of the shield *must not* be tied to anything, but allowed to float. This allows the shield to act as a drain.

Motor cabling in excess of 1 foot requires twisted pair shielded cable to reduce the transmission of EMI. The shield must be connected to AC ground at the driver. The other end of the shield *must not* be tied to anything, but allowed to float. This allows the shield to act as a drain.

Power supply leads to the driver need to be twisted. If more than one driver is to be connected to the same power supply, run separate power and ground leads from the supply to each driver.

Recommended Motor and Power Supply Cables:

Motor Cables

Dual Twisted Pair Shielded (Separate Shields)

- ≤ 4 Amps RMS per phase motor current.....Belden Part #9368 or equivalent 18 Gauge
- ≥ 4 Amps RMS per phase motor current.....Belden Part #1492A or equivalent 16 Gauge

Power Supply Cables

Twisted Pair (Jacketed)

- ≤ 4 Amps DC current.....Belden Part #9740 or equivalent 18 Gauge
- ≥ 4 Amps DC current.....Belden Part #8471 or equivalent 16 Gauge