



intelligent motion systems, inc.
Excellence in Motion™

PLANETARY GEARBOX

FOR IMS MDRIVE SERIES

QUICK REFERENCE



370 N. MAIN ST., PO BOX 457, MARLBOROUGH, CT 06447
PH: (860) 295-6102, FAX: (860) 295-6107
Internet: www.imshome.com, E-Mail: info@imshome.com

Planetary Gearbox Quick Reference Guide

The primary function of this guide is to acquaint the user with the specifications of the Planetary Gearbox offered as optional equipment for all IMS MDrive Series. More information is available from the IMS web site at www.imshome.com.

General Information

The Optional Planetary Gearbox are supplied in four sizes:

- 32mm diameter for the MDrive14
- 42mm diameter for the MDrive17
- 52mm diameter for the MDrive23
- 81mm diameter for the MDrive34

These Planetary Gearbox are supplied as 1-Stage, 2-Stage or 3-Stage units in a wide variety of ratios.

All Planetary Gearbox are Factory installed.

Mode of Function

Planetary Gearbox operate as their name implies: the motor-driven sun wheel is in the center, transmitting its movement to three circumferential planet gears which form one stage. They are arranged on the bearing pins of a planet carrier. The last planet carrier in each sequence is rigidly linked to the output shaft and so ensures the power transmission to the output shaft. The planet gears run in an internally toothed outer ring gear.

Service Life

Depending on ambient and environmental conditions and the operational specification of the driving system, the useful service life of a Planetary Gearbox is up to 10,000 hours. The wide variety of potential applications prohibits generalizing values for the useful service life.

Lubrication

All Planetary Gearbox are grease-packed and therefore maintenance-free throughout their life. The best possible lubricant has been selected for our MDrive/gearbox combinations.

Mounting Position

The grease lubrication and the different sealing modes allow the Planetary Gearbox to be installed in any position.

Operating Temperature

The temperature range for the Planetary Gearbox is between -30 and +140° C. However, the temperature range recommended for the Heat Sink of the MDrive is 0 to +85° C.

Overload torque

The permitted overload torque (shock load) is defined as a short-term increase in output torque, e.g. during the start-up of a motor. In these all-metal Planetary Gearbox, the overload torque can be as much as 1.5 times the permitted output torque.

Available Ratios

Available Ratios for Planetary Gearbox			
Stages	Rounded Ratio	Fractional Ratio	Decimal Ratio*
1-Stage	4:1	63 / 17	3.7058823529411764
	5:1	57 / 11	5.1818181818181818
	7:1	27 / 4	6.7500000000000000
2-Stage	14:1	3969 / 289	13.7335640138408304
	16:1	270 / 17	15.8823529411764705
	18:1	900 / 49	18.3673469387755102
	19:1	3591 / 187	19.2032085561497326
	22:1	1710 / 77	22.2077922077922077
	25:1	1701 / 68	25.0147058823529411
	27:1	3249 / 121	26.8512396694215000
	29:1	405 / 14	28.9285714285714876
	35:1	1539 / 44	34.9772727272727272
	46:1	729 / 16	45.5625000000000000
3-Stage	51:1	250047 / 4913	50.8949725218807246
	59:1	17010 / 289	58.8581314878892733
	68:1	8100 / 119	68.0672268907563025
	71:1	226223 / 3179	71.1616860648002516
	79:1	27000 / 343	78.7172011661807581
	93:1	107163 / 1156	92.7015570934256055
	95:1	51300 / 539	95.1762523191094619
	100:1	204687 / 2057	99.5075352455031599
	107:1	3645 / 34	107.2058823529411764
	115:1	97470 / 847	115.0767414403778040
	124:1	6075 / 49	123.9795918367346938
	130:1	96957 / 748	129.6216577540106951
	139:1	185193 / 1331	139.1382419233658903
	150:1	23085 / 154	149.9025974025974025
	169:1	45927 / 272	168.8492647058823529
	181:1	87723 / 484	181.2458677685950413
	195:1	10935 / 56	195.2678571428571428
	236:1	41553 / 176	236.0965909090909090
	308:1	19683 / 64	307.5468750000000000

* The Decimal Ratio shown here has been limited to 16 places.

Specifications

Dimensions in Inches (mm)

Planetary Gearbox with MDrive14

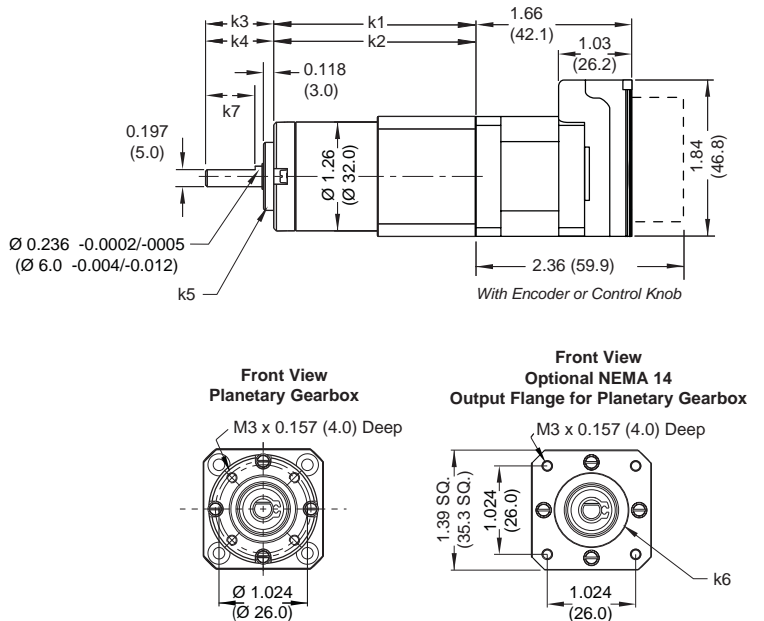

	Planetary Gearbox	1-Stage	2-Stage	3-Stage
Dimensions Inches (mm)	k1 Standard Gearbox	1.969 (50.0) ±0.02 (0.5)	2.343 (59.5) ±0.02 (0.5)	2.717 (60.0) ±0.02 (0.5)
	k2 w/NEMA Flange	2.008 (51.0) ±0.02 (0.5)	2.382 (60.5) ±0.02 (0.5)	2.756 (70.0) ±0.02 (0.5)
	k3 Standard Shaft	0.787 (20.0)		
	k4 Shaft w/NEMA Flange	0.748 (19.0)		
	k5 Standard Locator Diameter	0.787 (20.0) +0/-0.0013 (+0/-0.033)		
	k6 Locator Diameter w/NEMA Flange	0.866 (22.0) +0/-0.0013 (+0/-0.033)		
	k7 Length of Flat on Shaft	0.394 (10.0)		
Parameters	Max Output Torque	106 oz-in (0.75 Nm)	318 oz-in (2.25 Nm)	637 oz-in (4.5 Nm)
	Efficiency	80%	75%	70%
	Max Backlash	1.5°	2.0°	2.5°
Loads	Max Radial Load	9.0 lb-force (40 N)	15.7 lb-force (70 N)	22.0 lb-force (100 N)
	Max Axial Load	2.2 lb-force (10 N)	4.5 lb-force (20 N)	6.7 lb-force (30 N)
Weight	Gearbox Only	5.7 oz (162 gm)	7.5 oz (213 gm)	9.3 oz (264 gm)
	Gearbox w/NEMA Flange	5.9 oz (168 gm)	7.8 oz (221 gm)	9.6 oz (273 gm)

Dimensions in Inches (mm)

Planetary Gearbox with MDrive17

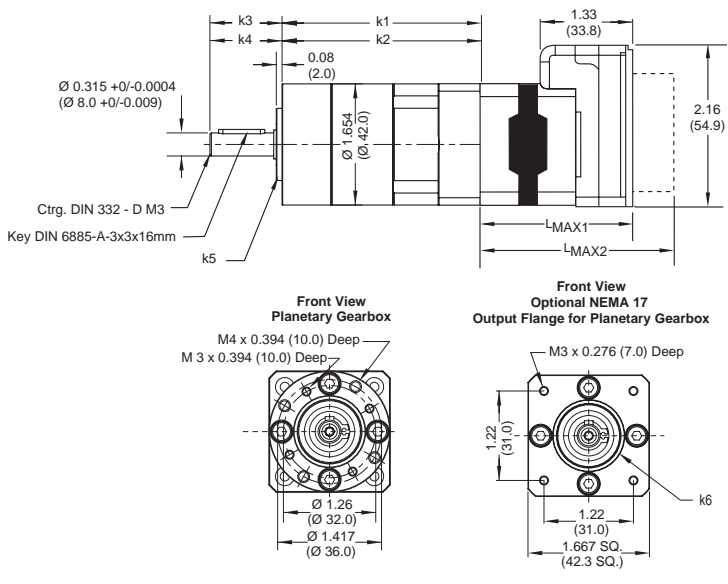

Dimensions (mm)	Planetary Gearbox	1-Stage	2-Stage	3-Stage
	k1	Standard Gearbox	2.736 (69.5) ± 0.02 (0.5)	3.248 (82.5) ± 0.02 (0.5)
k2	w/NEMA Flange	2.858 (72.6) ± 0.02 (0.5)	3.370 (85.5) ± 0.02 (0.5)	3.882 (98.6) ± 0.02 (0.5)
k3	Standard Shaft	0.984 (25.0)		
k4	Shaft w/NEMA Flange	0.846 (21.5)		
k5	Standard Locator Diameter	0.984 (25.0) $+0/-0.002$ ($+0/-0.052$)		
k6	Locator Diameter w/NEMA Flange	0.866 (22.0) $+0/-0.002$ ($+0/-0.052$)		
Parameters	Max Output Torque	425 oz-in (3.0 Nm)	1062 oz-in (7.5 Nm)	2124 oz-in (15.0 Nm)
	Efficiency	80%	75%	70%
	Max Backlash	0.80°	0.85°	0.90°
Loads	Max Radial Load	36 lb-force (160 N)	52 lb-force (230 N)	67.5 lb-force (300 N)
	Max Axial Load	11 lb-force (50 N)	18 lb-force (80 N)	25 lb-force (110 N)
Weight	Gearbox Only	14.3 oz (406 gm)	17.9 oz (508 gm)	21.5 oz (609 gm)
	Gearbox w/NEMA Flange	14.8 oz (420 gm)	18.5 oz (525 gm)	22.2 oz (630 gm)
Length (mm)	MDrive17	Size 1713	Size 1715	Size 1719
	L_{MAX1} Single Shaft Version	2.20 (55.9)	2.43 (61.7)	2.75 (69.8)
L_{MAX2} Encoder or Control Knob Version	2.92 (74.2)	3.15 (80.0)	3.47 (88.1)	

Planetary Gearbox with MDrive23

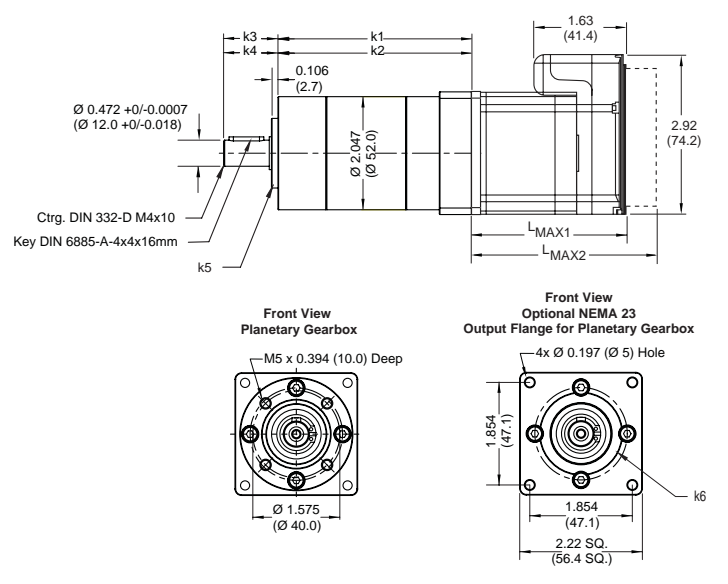

Dimensions (mm)	Planetary Gearbox	1-Stage	2-Stage	3-Stage
	k1	Standard Gearbox	2.976 (75.6) ± 0.02 (0.5)	3.531 (89.7) ± 0.02 (0.5)
k2	w/NEMA Flange	3.036 (77.1) ± 0.02 (0.5)	3.590 (91.2) ± 0.02 (0.5)	4.146 (105.3) ± 0.02 (0.5)
k3	Standard Shaft	0.984 (25.0)		
k4	Shaft w/NEMA Flange	0.925 (23.5)		
k5	Standard Locator Diameter	1.260 (32.0) $+0/-0.0015$ ($+0/-0.039$)		
k6	Locator Diameter w/NEMA Flange	1.50 (38.1) $+0/-0.0015$ ($+0/-0.039$)		
Parameters	Max Output Torque	566 oz-in (4.0 Nm)	1699 oz-in (12.0 Nm)	3540 oz-in (25.0 Nm)
	Efficiency	80%	75%	70%
	Max Backlash	0.70°	0.75°	0.80°
Loads	Max Radial Load	45 lb-force (200 N)	72 lb-force (320 N)	101 lb-force (450 N)
	Max Axial Load	13 lb-force (60 N)	22 lb-force (100 N)	34 lb-force (150 N)
Weight	Gearbox Only	25.0 oz (711 gm)	32.2 oz (914 gm)	39.4 oz (1117 gm)
	Gearbox w/NEMA Flange	25.9 oz (735 gm)	33.3 oz (945 gm)	40.7 oz (1155 gm)
Length (mm)	MDrive23	Size 2218	Size 2222	Size 2231
	L_{MAX1} Single Shaft Version	2.63 (66.8)	3.00 (76.2)	3.86 (98.0)
L_{MAX2} Encoder or Control Knob Version	3.35 (85.1)	3.70 (94.0)	4.57 (116.1)	

Planetary Gearbox with MDrive34

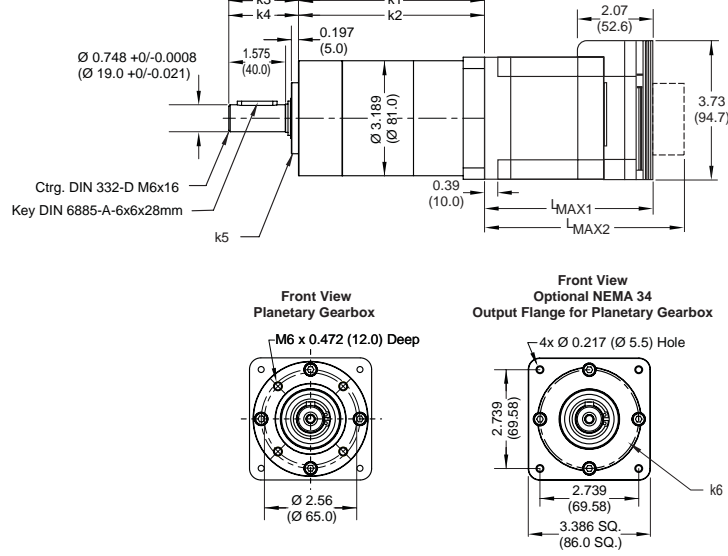

Dimensions (mm)	Planetary Gearbox	1-Stage	2-Stage	3-Stage
	k1	Standard Gearbox	4.315 (109.6) ± 0.02 (0.5)	5.169 (131.3) ± 0.02 (0.5)
k2	w/NEMA Flange	4.433 (112.6) ± 0.02 (0.5)	5.287 (134.3) ± 0.02 (0.5)	6.142 (156.0) ± 0.02 (0.5)
k3	Standard Shaft	1.929 (49.0)		
k4	Shaft w/NEMA Flange	1.811 (46.0)		
k5	Standard Locator Diameter	1.969 (50.0) $+0.0006/-0.0004$ ($+0.015/-0.010$)		
k6	Locator Diameter w/NEMA Flange	2.874 (73.0) $+0/-0.0012$ ($+0/-0.030$)		
Parameters	Max Output Torque	2832 oz-in (20.0 Nm)	8496 oz-in (60.0 Nm)	16992 oz-in (120.0 Nm)
	Efficiency	80%	75%	70%
	Max Backlash	1.0°	1.5°	2.0°
Loads	Max Radial Load	90 lb-force (400 N)	135 lb-force (600 N)	225 lb-force (1000 N)
	Max Axial Load	18 lb-force (80 N)	27 lb-force (120 N)	45 lb-force (200 N)
Weight	Gearbox Only	64.4 oz (1827 gm)	89.5 oz (2538 gm)	114.6 oz (3248 gm)
	Gearbox w/NEMA Flange	66.7 oz (1890 gm)	92.6 oz (2625 gm)	118.5 oz (3360 gm)
Length (mm)	MDrive34	Size 3424	Size 3431	Size 3447
	L_{MAX1} Single Shaft or Encoder Version	3.81 (96.8)	4.60 (116.80)	6.17 (156.7)
L_{MAX2} Control Knob Version	4.97 (126.2)	5.76 (146.3)	7.34 (186.4)	

MDrive with Planetary Gearbox: Installing a Driving Device



WARNING!

The MDrive and Heat Sink must not be subjected to any axial or other pressing force as damage may result to the unit and void the Warranty.

WARNING!

When installing a gear, pulley, coupling or other driving device to the Output Shaft of the Planetary Gearbox, IMS recommends that it be "slip-fit" to the shaft and properly secured, i.e. with set screws. **DO NOT** press fit the device onto the shaft.

NEVER tap or hammer a driving device onto the Output Shaft of the Planetary Gearbox.

WARNING!

Disconnecting the Planetary Gearbox from the MDrive may void the Warranty.