

Quick Reference MForce PowerDrive Microstepping



IMS
INTELLIGENT MOTION
SYSTEMS, INC.

Schneider
Electric

Notes and Warnings

Installation, configuration and maintenance must be carried out by qualified technicians only. You must have detailed information to be able to carry out this work. This information can be found in the user manual.

- Unexpected dangers may be encountered when working with this product!
- Incorrect use may destroy this product and connected components!

The user manual is not included, but may be obtained from the Internet at: <http://www.imshome.com/downloads/manuals.html>.

Required for Setup*

- PC running Microsoft® Windows XP Service Pack 2 or greater.
- SPI Motor Interface (available online).
- +12 to +75 VDC unregulated linear or switching power supply.
- NEMA size 23 or 34 stepping motor.
- 0 to 5 MHz Clock signal for step clock, may be a controller high speed output or signal generator.
- SPST switch or controller I/O point to control axis direction.
- SPI communications interface (recommended: MD-CC303-001 communication converter).

Depending on your MForce PowerDrive connectors configuration, you may also need:

- I/O and Communications interface to 12-pin wire crimp connector (recommended: PD12-1434-FL3 prototype development cable).
- Power interface to 2-pin wire crimp connector (recommended: PD02-3400-FL3).
- Motor interface to 4-pin wire crimp connector (recommended: PD04-MF34-FL3).

* If you purchased your MForce PowerDrive with a QuickStart Kit, you have received all of the connecting cables needed for initial functional setup and system testing.

Getting Started

All documentation, software and resources are available online at: http://www.imshome.com/products/mforce_overview.html.

Connecting the Motor, Power and I/O

Your MForce PowerDrive is configured with power and I/O on separate connectors. Please refer to the opposite side of this document for connecting details and available connectivity options.

Connecting Communications

1. Connect USB to SPI communications converter to MForce PowerDrive and PC.
2. Install the communication converter drivers onto PC (available online).
3. Install and open SPI Motor Interface.
4. Apply power to MForce PowerDrive.
5. Parameters may be adjusted via two screens, the Motor Settings screen or the I/O Settings screen (shown below), accessible via the View menu.

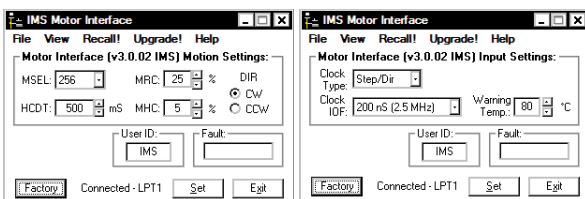

Motor Settings Screen

I/O Settings Screen

Specifications

Electrical Specifications

Input Voltage (+V) Range*	+12 to +75 VDC
Max Power Supply Current (Per MForce PowerDrive)*	4 A
Output Current (RMS)	5.0 Amps
Output Current (Peak)	7.0 Amps

*Actual Power Supply Current will depend on voltage and load.

Environmental Specifications

Operating Temperature - measured at the heat sink (non-condensing humidity)	-40°C to +85°C
---	----------------

Isolated Input Specifications

Step Clock, Direction and Enable

Voltage Range (Sinking or Sourcing)	+5 to +24 VDC
Current (+5V Max)	8.7 mA
Current (+24V Max)	14.6 mA

Motion Specifications

Digital Filter Range	50 nS to 12.9 μS (10 MHz to 38.8 kHz)
Clock Types	Step/Direction, Up/Down, Quadrature
Step Frequency (Max)	5 MHz
Step Frequency Minimum Pulse Width	100 nS
Number of Microstep Resolution Settings	20

Available Microsteps Per Revolution									
200	400	800	1000	1600	2000	3200	5000	6400	10000
12800	20000	25000	25600	40000	50000	51200	36000 ¹	21600 ²	25400 ³

1=0.01 deg/μstep 2=1 arc minute/μstep 3=0.001 mm/μstep

Setup Parameters

Setup Parameters

Name	Function	Range	Units	Default
MHC	Motor Hold Current	0 to 100	Percent	5
MRC	Motor Run Current	1 to 100	Percent	25
MSEL	Microstep Resolution	See Motion Specifications	μsteps/ Full Step	256
DIR	Motor Direction Override	0/1	—	CW
HCDDT	Hold Current Delay Time	0 or 2 - 65535	mSec	500
CLK TYPE	Clock Type	See Motion Specifications	—	Step/ Direction
CLK IOF	Clock Input Filter	50 nS to 12.9 μS (10 MHz to 38.8 kHz)	nS (MHz)	200 nS (2.5MHz)
EN ACT	Enable Active High/Low	High/Low	—	High
USER ID	User ID	3 Characters Viewable ASCII	Viewable ASCII	IMS

Mechanical Specifications

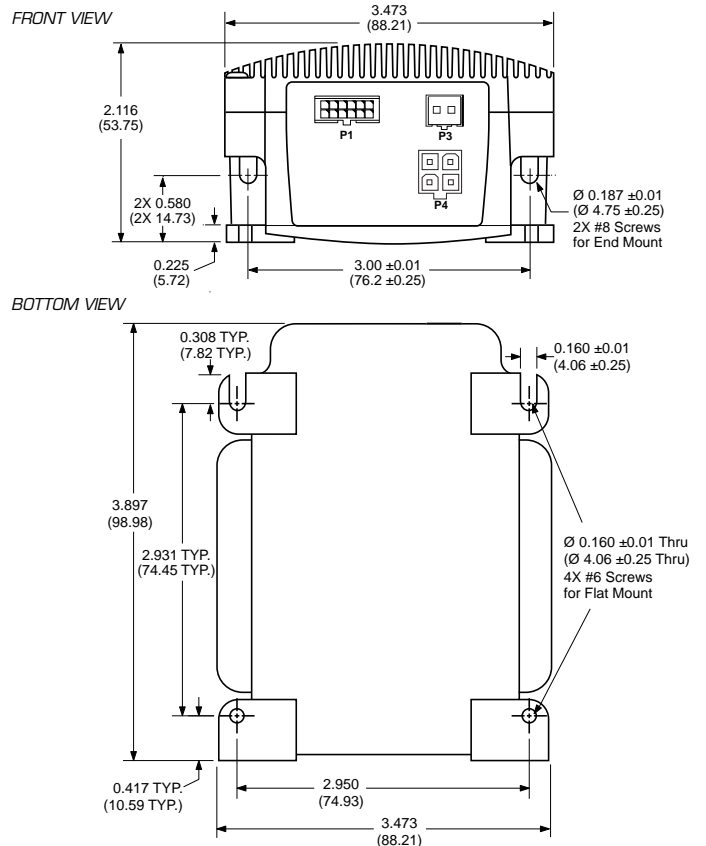

Minimum Required Connections

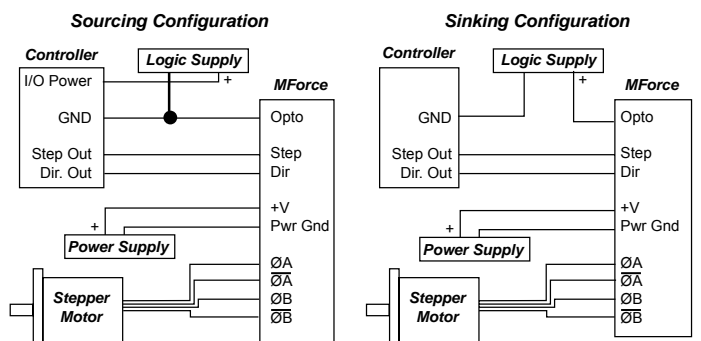

MForce PowerDrive Microstepping Connectivity Options

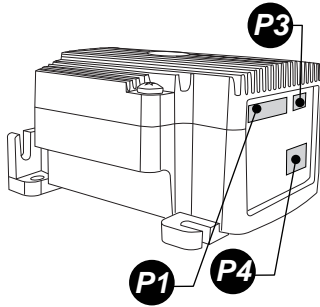

Connector Style	Function
P1 Flying Leads.....	I/O, Power & Encoder
12-pin Wire Crimp.....	I/O and Communications
P3 2-Pin Wire Crimp.....	Power
P4 4-pin Wire Crimp.....	Motor

P1 I/O & Communications

12-pin wire crimp

Chip Select	11 12	SPI MISO
Comm Gnd	9 10	SPI MOSI
+5 VDC	7 8	SPI Clock
Enable	5 6	Direction
Opto Ref	3 4	Step Clock
N/C	1 2	N/C

CONNECTOR PRODUCT ALERT! October 2009

Disregard these pin number markings. Use the pin numbering scheme shown above.

The manufacturer of this 12-pin wire crimp connector has begun marking the connector shell, PN 1-794617-2 with pin numbers shown here.

Communications Converter p/n: MD-CC303-001

Electrically isolated in-line USB to SPI converter pre-wired with mating connector to conveniently program and set configuration parameters. A secondary cable from the mating connector provides interface to power and I/O.

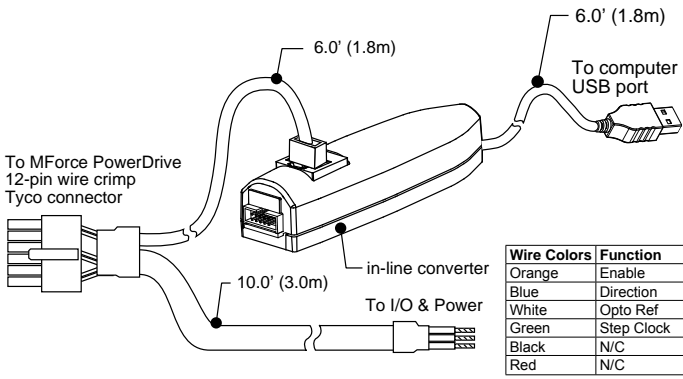

Prototype Development Cable p/n: PD12-1434-FL3

Speed test and development with pre-wired mating connector.

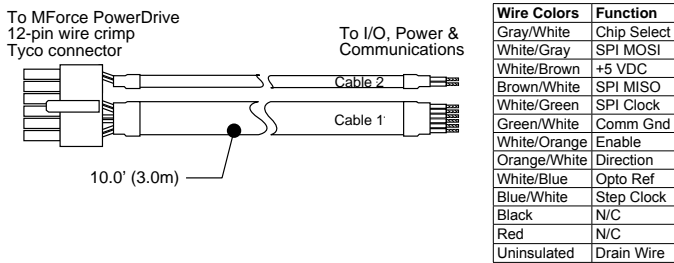

Mating Connector Kit p/n: CK-03

Use to make your own cables, kit contains 5 mating connector shells for making interface cables. Tyco crimp tool recommended.

Tyco Parts Shell: 1-794617-2
Pins: 794610-1

P3 Power

2-pin wire crimp

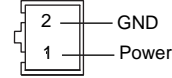

Prototype Development Cable p/n: PD02-3400-FL3

Function: Power Interface

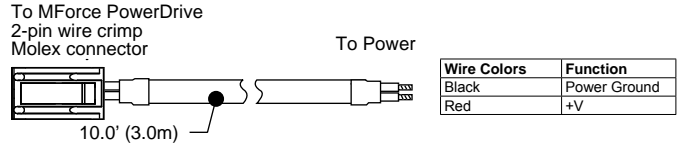

Mating Connector Kit p/n: CK-05

Use to make your own cables, kit contains 5 mating connector shells with crimp pins. Tyco crimp tool recommended.

Molex Parts Shell: 510-67-0200
Pins: 502-17-91011

P4 Motor

4-pin wire crimp

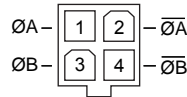

ENSURE PROPER CONNECTION OF THE MOTOR PHASES!

Prototype Development Cable p/n: PD04-MF34-FL3

Function: Motor Interface

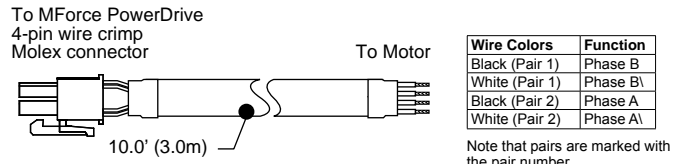

Mating Connector Kit p/n: CK-07

Use to make your own cables, kit contains 5 mating connector shells with crimp pins. Molex crimp tool recommended.

Molex Parts Shell: 39-01-2045
Pins: 44476-3112