

# Quick Reference MDrive® 23 Hybrid Motion Control



## Notes and Warnings

Installation, configuration and maintenance must be carried out by qualified technicians only. You must have detailed information to be able to carry out this work. This information can be found in the user manuals.

- Unexpected dangers may be encountered when working with this product!
- Incorrect use may destroy this product and connected components!

The user manuals are not included, but may be obtained from the Internet at: <http://www.imshome.com/downloads/manuals.html>.

## Required for Setup\*

- PC running Microsoft® Windows XP Service Pack 2 or greater.
- IMS Terminal integrated program editor and terminal emulator (available online).
- +12 to +60 VDC unregulated linear or switching power supply.
- RS-422/485 communication version (recommended: MD-CC402-001 communication converter).
- Ethernet version: CAT5/6 cabling with RJ45 connectors.

You may also need:

- Power interface to 2-pin wire crimp connector (recommended: PD02-2300-FL3 prototype development cable).
- I/O interface to 14-pin wire crimp connector (recommended: PD14-2334-FL3 prototype development cable).

\* If you purchased your MDrive Hybrid with a QuickStart Kit, you have received all of the connecting cables needed for initial functional setup and system testing.

## Getting Started

All documentation, software and resources are available online at: [http://www.imshome.com/products/mdrive\\_motor\\_driver.html](http://www.imshome.com/products/mdrive_motor_driver.html).

### Connecting Power and I/O

Please refer to the opposite side of this document for connecting details and available connectivity options including prototype development cables and mating connector kits.

### Connecting Communication — RS-422/485

1. Connect RS-422/485 communications converter to MDrive Hybrid and PC.
2. Install the communication converter drivers onto PC (available online).
3. Install and open IMS Terminal.
4. Apply power to the device.
5. Within IMS Terminal, click into the Terminal Window (shown below).
6. Key in CTRL+C. The sign-on message: "Copyright 2001-2010 by Schneider Electric Motion USA" should appear, verifying that communications is active.

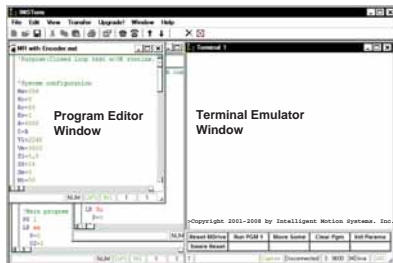

### Connecting Communication — Ethernet

1. Connect Ethernet CAT5/6 cable (only available with Quick Start kit purchase) with RJ45 connector to MDrive Hybrid and PC or switch.
2. Using IMS Terminal, go to Edit > Preferences, select the Comm Settings tab.
3. Check the TCP option, in the IP address dropdown, select 192.168.33.1.
4. Connect and use as shown in Step 5 and 6 of the RS-422/485 procedure above.

If changing the IP address or using in MODBUS/TCP mode, please reference the product manuals.

## Connecting Communications — CANopen

A "Getting Started" tutorial using the CANopen Tester GUI with the MD-CC500-000 USB to CANopen dongle is located in the CANopen implementation manual, available online.

## General Specifications

Electrical Specifications	
Input Voltage (+V) Range*	+12 to +60 VDC
Max Power Supply Current (Per MDrive)*	2 A
Aux-Logic Input Voltage**	+12 to +24 VDC
Aux-Logic Input Current**	194 mA Max

\*Actual Power Supply Current will depend on voltage and load.  
\*\*Used to power logic circuitry in the absence of +V.

Environmental Specifications		
Operating Temperature (non-condensing)	Heat Sink	-40°C to +85°C
	Motor	-40°C to +100°C

I/O Specifications	
<b>General Purpose I/O - Number and Type</b>	
I/O Points 1-4, 9-12	8 I/O programmable as inputs or outputs (sinking or sourcing)
<b>General Purpose I/O - Electrical</b>	
Inputs	TTL up to +24 VDC
Sinking Outputs	Up to +24 VDC
Sourcing Outputs	+12 to +24 VDC
Output Sink Current	up to 600 mA (One Channel in each I/O Bank)
Logic Threshold (Logic 0)	< 0.8 VDC
Logic Threshold (Logic 1)	> 2.2 VDC
Protection (Sinking)	Over Temp, Short Circuit
Protection (Sourcing)	Transient, Over Voltage, Inductive Clamp
<b>Analog Input</b>	
Resolution	10 Bit
Range (Voltage Mode)	0 to +5 VDC, 0 to +10 VDC
Range (Current Mode)	4 to 20 mA, 0 to 20mA
<b>Trip Output/Capture Input</b>	
Logic Threshold	+5V TTL Input, TTL Output (with 2 kΩ Load to Ground)

Communications Specifications	
Protocol	RS-422/RS-485 or Ethernet
BAUD Rate (not applicable to Ethernet)	4.8k, 9.6k, 19.2k, 38.4k, 115.2 kbps

Motion Specifications	
<b>Microstep Resolution - Open Loop</b>	
Number of Resolutions	20

Available Microsteps Per Revolution									
200	400	800	1000	1600	2000	3200	5000	6400	10000
12800	20000	25000	25600	40000	50000	51200	36000 <sup>1</sup>	21600 <sup>2</sup>	25400 <sup>3</sup>

1=0.01 deg/μstep 2=1 arc minute/μstep 3=0.001 mm/μstep

Software Specifications	
Program Storage Type/Size	Flash/6384 Bytes
User Program Labels and Variables	192
Party Mode Addresses	62

## Mechanical Specifications

Dimensions in inches (mm)

NOTE: For linear actuator products, see manual for screw specifications

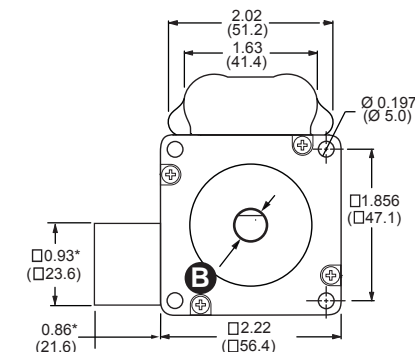
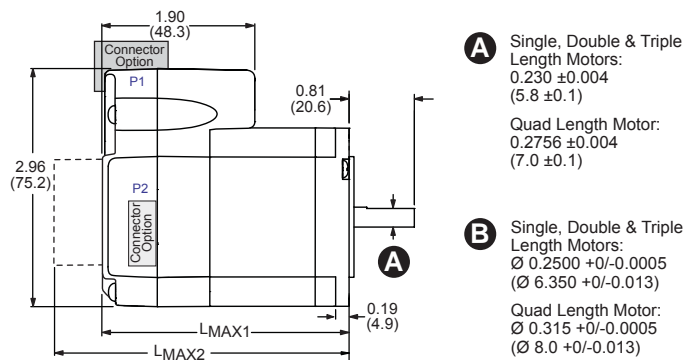

\*Ethernet version only

Motor stack length	Lmax (1)	Lmax2 (2)
Single	2.65 (67.31)	3.36 (85.34)
Double	3.02 (76.71)	4.59 (116.59)
Triple	3.88 (98.55)	4.59 (116.59)
Quad	5.28 (134.15)	5.99 (152.19)

- (1) Single shaft.  
(2) Control knob.

# MDrive 23 Hybrid Motion Control Connectivity Options

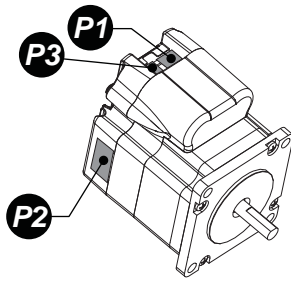

Connector Style                      Function

- P1** 14-pin Wire Crimp..... I/O
- P2** 10-pin Wire Crimp..... Communication  
RJ45(Ethernet only)..... Communication  
DB-9M (CANopen only)..... Communication
- P3** 2-pin Wire Crimp..... Power

## **P1** I/O

14-pin wire crimp

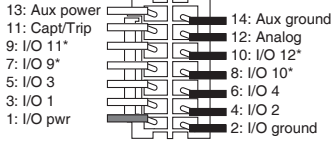

\* Not connected on Ethernet version

**Prototype Development Cable p/n: PD14-2334-FL3**  
Speed test and development with pre-wired mating connector.

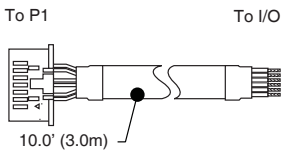

Pair	Wire Colors	RS-422/485	Ethernet
1	White	Aux Power	Aux Power
	Black	Aux Ground	Aux Ground
2	Green	Capt/Trip	Capt/Trip
	Black	Analog In	Analog In
3	Blue	I/O11	Not Connected
	Black	I/O12	Not Connected
4	Yellow	I/O9	Not Connected
	Black	I/O10	Not Connected
5	Brown	I/O3	I/O3
	Black	I/O4	I/O4
6	Orange	I/O1	I/O1
	Black	I/O2	I/O2
7	Red	I/O Power	I/O Power
	Black	I/O Ground	I/O Ground

## **P2** Communication — RS-422/485

10-pin wire crimp

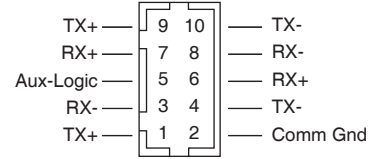

**Communication Converter p/n: MD-CC402-001**

Electrically isolated in-line USB to RS-422/485 converter pre-wired with mating connector to conveniently program and set configuration parameters.

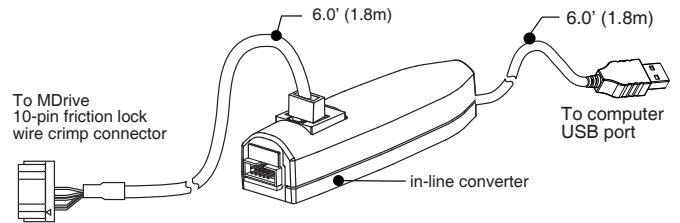

**Prototype Development Cable p/n: PD10-1434-FL3**

Speed test and development with pre-wired mating connector. Recommended for multi-drop systems, can be used in conjunction with the MD-CC402-001.

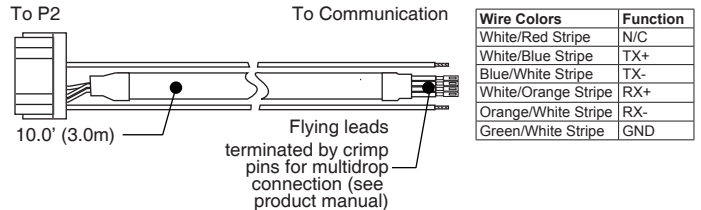

## **P3** Power

2-pin wire crimp

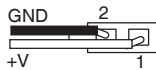

**Prototype Development Cable p/n: PD02-2300-FL3**  
Function: Power Interface

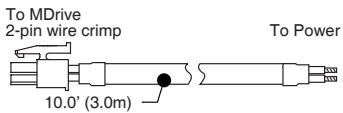

Wire Colors	Function
Black	Power Ground
Red	+V

**Mating Connector Kit p/n: CK-04**

Use to make your own cables, kit contains 5 mating connector shells with crimp pins. Tyco crimp tool recommended.

Tyco Parts                      Shell: 794617-2  
Pins: 794610-1

**Mating Connector Kit p/n: CK-02**

Use to make your own cables, kit contains 5 mating connector shells with crimp pins. Hirose crimp tool recommended.

Hirose Parts                      Shell: DF11-10DS-2C  
Pins: DF11-2428SC

## **P2** Communication — Ethernet

RJ45 (Ethernet version only)

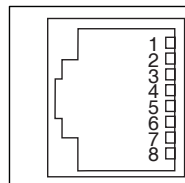

The Ethernet version MDriveHybrid uses standard wiring configuration with CAT5/6 cabling with RJ45 ends

## **P2** Communications — CANopen version

DB-9 (male)

**Communications Converter p/n: MD-CC500-000**

Electrically isolated in-line USB to CANopen converter. USB "A" Type connector to DB-9 (Male). An interface cable must be constructed by the user.

**Mating Cable Requirements**

The following diagram illustrates the parts and connections for an interface cable connecting the MD-CC500-000 to the MDrive. Required Parts: (2) DB-9 (female), (1) 120Ω terminating resistor

