

# MDrive® 34ac Hybrid Motion Control



## Notes and Warnings

Installation, configuration and maintenance must be carried out by qualified technicians only. You must have detailed information to be able to carry out this work. This information can be found in the user manuals.

- Unexpected dangers may be encountered when working with this product!
- Incorrect use may destroy this product and connected components!

The user manuals are not included, but may be obtained from the Internet at: <http://www.imshome.com/downloads/manuals.html>.

## Required for Setup\*

- PC running Microsoft® Windows XP Service Pack 2 or greater.
- IMS Terminal integrated program editor and terminal emulator (available online).
- MD-CS200-000 or equivalent Lumberg Euro AC cable for AC line (required for UL recognition).
- RS-422/485 communications interface (recommended: MD-CC401-001 communication converter).

Depending on your MDrive connectors configuration, you may also need:

- I/O and Power interface to 19-pin M23 circular connector (recommended: MD-CS100-000 or MD-CS101-000 prototype development cordset).

\* If you purchased your MDrive Hybrid with a QuickStart Kit, you have received all of the connecting cables needed for initial functional setup and system testing.

## Getting Started

All documentation, software and resources are available online at: [http://www.imshome.com/products/mdrive\\_motor\\_driver.html](http://www.imshome.com/products/mdrive_motor_driver.html).

### Connecting Power and I/O

Your MDrive is configured with power and I/O on separate connectors. Please refer to the opposite side of this document for connecting details and available connectivity options including prototype development cables and recommendations.

### Connecting Communications — RS-422/485

1. Connect RS-422/485 communications converter to MDrive and PC.
2. Install the communication converter drivers onto PC (available online).
3. Install and open IMS Terminal.
4. Apply power to MDrive.
5. Within IMS Terminal, Click into the Terminal Window (shown below).
6. Key in CTRL+C. The MDrive sign-on message: "Copyright © 2010 Schneider Electric Motion USA" should appear, verifying that communications is active.

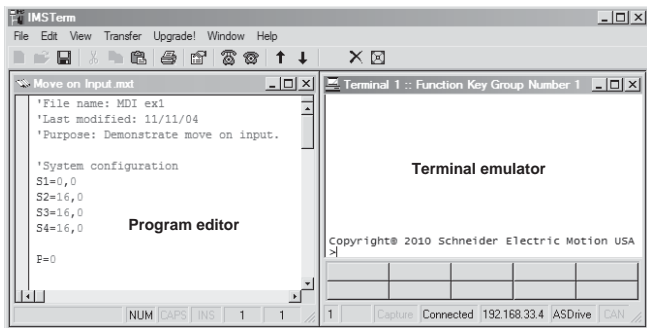

## General Specifications

Electrical Specifications	
Input Voltage Range (120 VAC MDrive)	95 to 132 VAC @ 50/60 Hz
Input Current (120 VAC MDrive)	4.2 Amps
Input Voltage Range (240 VAC MDrive)	95 to 264 VAC @ 50/60 Hz
Input Current (240 VAC MDrive)	2.1 Amps
Aux-Logic Input Voltage	+12 to +24 VDC
Aux-Logic Input Current	230 mA Max

Environmental Specifications		
Operating Temperature (non-condensing)	Heat Sink	-40°C to +75°C
	Motor	-40°C to +90°C
Sealing		IP65

I/O Specifications	
General Purpose I/O - Number and Type	
I/O Points 1-4, 9-12	8 programmable I/O Points - sinking or sourcing inputs or outputs.
General Purpose I/O - Electrical	
Inputs	TTL, +5 to +24 VDC
Sinking Outputs	+5 to +24 VDC
Sourcing Outputs	+12 to +24 VDC
Output Sink Current	up to 600 mA
Logic Threshold (Logic 0)	< 0.8 VDC
Logic Threshold (Logic 1)	> 2.2 VDC
Protection (Sinking)	Over Temp, Short Circuit
Protection (Sourcing)	Transient, over voltage, inductive clamp
Analog Input	
Resolution	10 Bit
Range (Voltage Mode)	0 to +5 VDC, 0 to +10 VDC
Range (Current Mode)	4 to 20 mA, 0 to 20mA
Trip Output/Capture Input	
Logic Threshold	TTL Input, TTL Output (with 2 kΩ Load to Ground)

Communications Specifications	
Protocol	RS-422/RS-485
BAUD Rate	4.8k, 9.6k, 19.2k, 38.4k, 115.2 kbps

Protection Specifications	
Thermal	
Internal Fuse (line-neutral systems only, line-line systems require external fusing)	

Motion Specifications	
Microstep Resolution - Open Loop	
Number of Resolutions	20

Available Microsteps Per Revolution									
200	400	800	1000	1600	2000	3200	5000	6400	10000
12800	20000	25000	25600	40000	50000	51200	36000 <sup>1</sup>	21600 <sup>2</sup>	25400 <sup>3</sup>

1=0.01 deg/μstep    2=1 arc minute/μstep    3=0.001 mm/μstep

Software Specifications	
Program Storage Type/Size	Flash/6384 Bytes
User Program Labels and Variables	192
Party Mode Addresses	62

## Mechanical Specifications

Dimensions in inches (mm)

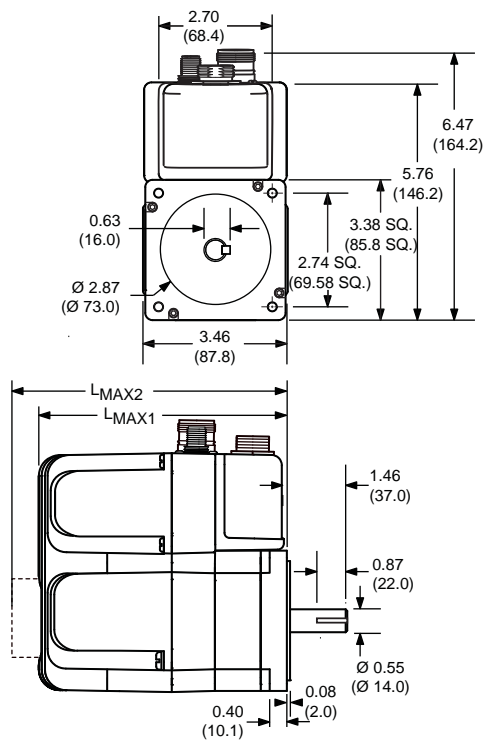

Motor stack length	Lmax (1)	Lmax2 (2)
Single	6.1 (155.0)	7.1 (180.4)
Double	6.9 (174.3)	7.9 (199.7)
Triple	8.4 (214.3)	9.4 (239.7)

(1) Single shaft.  
(2) Control knob.

# MDrive 34ac Hybrid Motion Control Connectivity Options

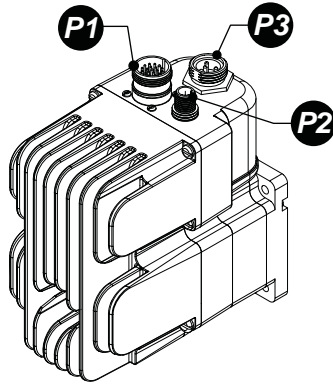

Connector Style                      Function

- P1** 19-pin M23 Circular (male)..... I/O
- P2** 5-Pin M12 Circular (female)..... Communications
- P3** 3-pin Euro AC (male)..... AC Power

## **P1** I/O

19-pin M23 circular connector (male)

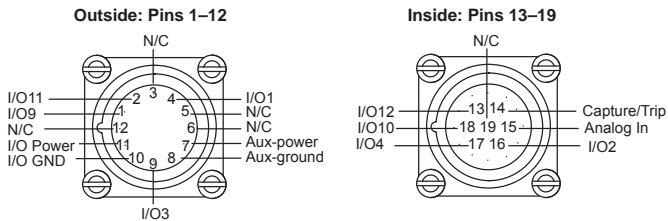

### Prototype Development Cordset

p/n (straight connector): MD-CS100-000  
p/n (right-angle connector): MD-CS101-000

Pre-wired mating connector interfaces to the 19-pin M23 circular connector, with flying leads other end, for quick test/development.

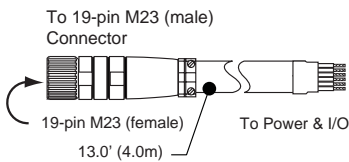

Wire Colors	Function
Violet	I/O9
Red	I/O11
Gray	N/C
Red/Blue	I/O1
Green	N/C
Blue	N/C
Gray/Pink	Aux-power
White/Green	Comm GND
White/Yellow	I/O3
White/Gray	I/O GND
Black	I/O Power
Green/Yellow	N/C
Yellow/Brown	I/O12
Brown/Green	Capture/Trip
White	Analog In
Yellow	I/O2
Pink	I/O4
Gray/Brown	I/O10
Brown	N/C

### Mating Connector Recommendations

MD-CS100-000 recommended with 19-pin M23 connector.

For comparable connector only, shop vendors:

- Lumberg
- Phoenix
- Turck
- RDE Connectors

## **P3** AC Power

3-pin Euro AC connector (male)

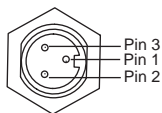

### Prototype Development Cordset

p/n (straight connector): MD-CS200-000  
p/n (right-angle connector): MD-CS201-000

Pre-wired mating connector interfaces to the 3-pin circular EuroAC connector, with flying leads other end, for quick test/development.

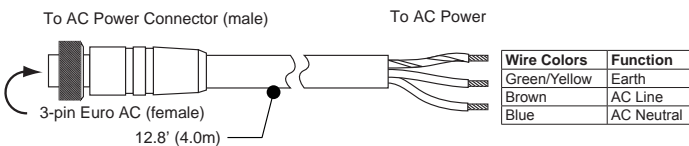

Wire Colors	Function
Green/Yellow	Earth
Brown	AC Line
Blue	AC Neutral

### Mating Connector Recommendations

The following field-solderable mating connector is recommended for use with the MDrive Hybrid 34ac.

Lumberg: RKC 30/11

## **P2** Communications — RS-422/485

5-pin M12 circular connector (female)

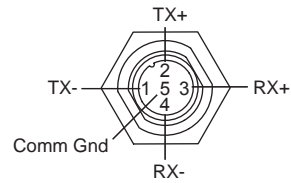

### Communications Converter p/n: MD-CC401-001

Electrically isolated in-line USB to RS-422/485 converter pre-wired with mating connector to conveniently program and set configuration parameters.

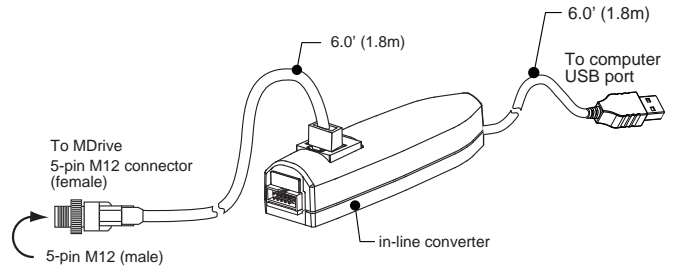

### Mating Connector Recommendations

MD-CC401-001 recommended with: 5-pin M12 connector.

For comparable connector only, shop vendor:

- Lumberg
- Phoenix
- Turck
- RDE Connectors

## UL Conditions of Acceptability

When used in end-product equipment, the following are among the considerations to be made:



The temperature tests were conducted with the device's face mounted to an aluminum heat sink. For devices with the frame designation 34, the dimensions for the heat sink were 10" x 10" x 1/4". The shaft was also provided with aluminum wheels, approximately 4" in diameter and 1/4" thick.

These devices are intended for installation in a Pollution Degree 2 (controlled) environment. Suitability of the spacings shall be considered in end-use application.

The enclosure of this device is intended as the final end-use enclosure.

These devices do not provide motor overload protection.

These devices have not been subjected to the short circuit test. This test shall be considered in the end-product investigation.

The following MDrive AC products are excluded from UL Recognition:



1. MDrive AC models with a rear motor shaft extension, i.e. Control Knob versions