



INTELLIGENT MOTION SYSTEMS, INC.

Excellence in Motion™

PLANETARY GEARBOX

FOR IMS HYBRID STEPPING MOTORS

QUICK REFERENCE



370 N. MAIN ST., PO BOX 457, MARLBOROUGH, CT 06447
 PH: (860) 295-6102, FAX: (860) 295-6107
 Internet: www.imshome.com, E-Mail: info@imshome.com

Planetary Gearbox Quick Reference Guide

The primary function of this guide is to acquaint the user with the specifications of the Planetary Gearboxes offered as optional equipment for the IMS HYBRID Stepping Motor series. More information is available from the IMS web site at www.imshome.com.

General Information

The Planetary Gearboxes are supplied in four sizes:

- P32 for the NEMA Size 14 Stepping Motor
- P42 for the NEMA Size 17 Stepping Motor
- P52 for the NEMA Size 23 Stepping Motor
- P81 for the NEMA Size 34 Stepping Motor

These Gearboxes are supplied as 1-Stage, 2-Stage or 3-Stage units in a wide variety of ratios.

All Gearboxes are Factory installed.

Mode of Function

Planetary Gearboxes (PLGs) operate as their name implies: the motor-driven sun wheel is in the center, transmitting its movement to three circumferential planet gears which form one stage. They are arranged on the bearing pins of a planet carrier. The last planet carrier in each sequence is rigidly linked to the output shaft and so ensures the power transmission to the output shaft. The planet gears run in an internally toothed outer ring gear.

Service Life

Depending on ambient and environmental conditions and the operational specification of the driving system, the useful service life of a PLG is up to 10,000 hours. The wide variety of potential applications prohibits generalizing values for the useful service life.

Lubrication

All PLGs are grease-packed and therefore maintenance-free throughout their life. The best possible lubricant has been selected for our motor/gearbox combinations.

Mounting Position

The grease lubrication and the different sealing modes allow the Planetary Gears to be installed in any position.

Operating Temperature

The temperature range for the gearbox is between -30 and +140° C. However, the operating temperature range recommended for HYBRID Stepper motors is -20 to +100° C.

Overload torque

The permitted overload torque (shock load) is defined as a short-term increase in output torque, e.g. during the start-up of a motor. In these all-metal PLGs, the overload torque can be as much as 1.5 times the permitted output torque.

Available Ratios

Stages	Rounded Ratio	Motor Speed/ Output Speed	Reduction Ratio
1-Stage	4	63/17	3.7058823529411800
	5	57/11	5.1818181818181800
	7	27/4	6.7500000000000000
2-Stage	14	3969/289	13.7335640138408000
	16	270/17	15.8823529411765000
	18	900/49	18.3673469387755000
	19	3591/187	19.2032085561497000
	22	1710/77	22.2077922077922000
	25	1701/68	25.0147058823529000
	27	3249/121	26.8512396694215000
	29	405/14	28.9285714285714000
	35	1539/44	34.9772727272727000
3-Stage	46	729/16	45.5625000000000000
	51	250047/4913	50.8949725218807000
	59	17010/289	58.8581314878893000
	68	8100/119	68.0672268907563000
	71	226223/3179	71.1616860648003000
	79	27000/343	78.7172011661808000
	93	107163/1156	92.7015570934256000
	95	51300/539	95.1762523191095000
	100	204687/2057	99.5075352455032000
	107	3645/34	107.2058823529410000
	115	97470/847	115.0767414403780000
	124	6075/49	123.9795918367350000
	130	96957/748	129.6216577540110000
	139	185193/1331	139.1382419233660000
	150	23085/154	149.9025974025970000
	169	45927/272	168.8492647058820000
	181	87723/484	181.2458677685950000
	195	10935/56	195.2678571428570000
236	41553/176	236.0965909090910000	
308	19683/64	307.5468750000000000	

Specifications

Dimensions in Inches (mm)

P32 Planetary Gearbox with Size 14 Stepping Motor

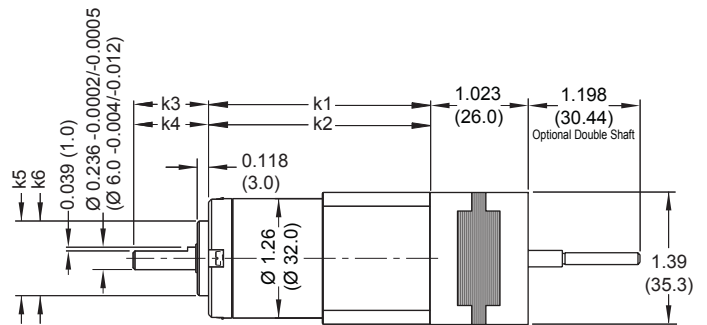

Front View
P32 Planetary Gearbox
M3 x 0.157 (4.0) Deep

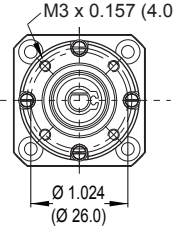

Front View
Optional NEMA 14 Output Flange for P32
M3 x 0.157 (4.0) Deep

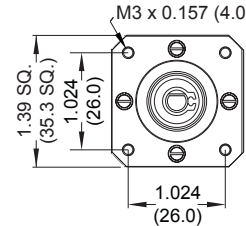

	Planetary Gearbox	1-Stage	2-Stage	3-Stage
Dimensions Inches (mm)	k1 Standard Gearbox	1.969 (50.0) ±0.02 (0.5)	2.343 (59.5) ±0.02 (0.5)	2.717 (69.0) ±0.02 (0.5)
	k2 w/NEMA Flange	2.008 (51.0) ±0.02 (0.5)	2.382 (60.5) ±0.02 (0.5)	2.756 (70.0) ±0.02 (0.5)
	k3 Standard Shaft	0.787 (20.0)		
	k4 Shaft w/NEMA Flange	0.748 (19.0)		
	k5 Standard Locator Diameter	0.787 (20.0) +0/-0.0013 (+0/-0.033)		
	k6 Locator Diameter w/NEMA Flange	0.866 (22.0) +0/-0.002 (+0/-0.052)		
Parameters	Max Output Torque	106 oz-in (0.75 Nm)	318 oz-in (2.25 Nm)	637 oz-in (4.5 Nm)
	Efficiency	80 %	75 %	70 %
	Max Backlash	1.5°	2.0°	2.5°
Loads	Max Radial Load	9.0 lb-force (40 N)	15.7 lb-force (70 N)	22.0 lb-force (100 N)
	Max Axial Load	2.2 lb-force (10 N)	4.5 lb-force (20 N)	6.7 lb-force (30 N)
	Max Permissible Fitting Pressure	27.0 lb-force (120 N)	27.0 lb-force (120 N)	27.0 lb-force (120 N)
Weight	Gearbox Only	5.7 oz (162 gm)	7.5 oz (213 gm)	9.3 oz (264 gm)
	Gearbox w/NEMA Flange	5.9 oz (168 gm)	7.8 oz (221 gm)	9.6 oz (273 gm)

Dimensions in Inches (mm)

P42 Planetary Gearbox with Size 17 Stepping Motor

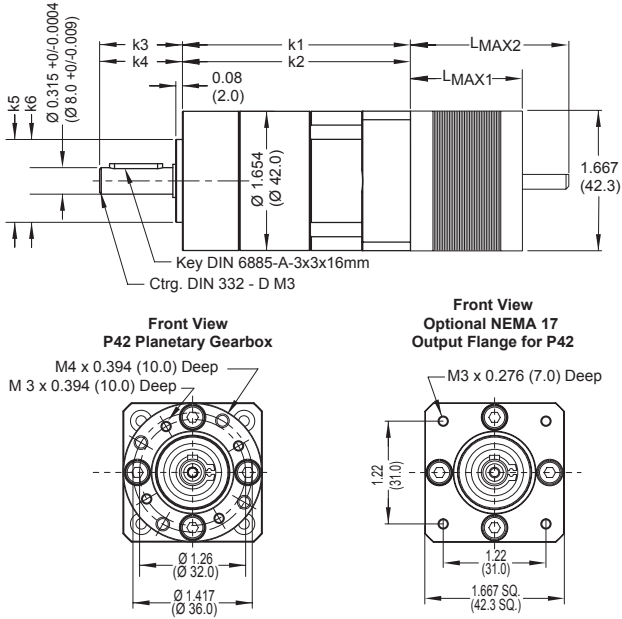

		Planetary Gearbox	1-Stage	2-Stage	3-Stage
Dimensions Inches (mm)	k1	Standard Gearbox	2.736 (69.5) ±0.02 (0.5)	3.248 (82.5) ±0.02 (0.5)	3.760 (95.5) ±0.02 (0.5)
	k2	w/NEMA Flange	2.858 (72.6) ±0.02 (0.5)	3.370 (85.6) ±0.02 (0.5)	3.882 (98.6) ±0.02 (0.5)
	k3	Standard Shaft	0.984 (25.0)		
	k4	Shaft w/NEMA Flange	0.846 (21.5)		
	k5	Standard Locator Diameter	0.984 (25.0) +0/-0.002 (+0/-0.052)		
	k6	Locator Diameter w/NEMA Flange	0.866 (22.0) +0/-0.002 (+0/-0.052)		
Parameters	Max Output Torque	425 oz-in (3.0 Nm)	1062 oz-in (7.5 Nm)	2124 oz-in (15.0 Nm)	
	Efficiency	80 %	75 %	70 %	
	Max Backlash	0.80°	0.85°	0.90°	
Loads	Max Radial Load	36 lb-force (160 N)	52 lb-force (230 N)	67.5 lb-force (300 N)	
	Max Axial Load	11 lb-force (50 N)	18 lb-force (80 N)	25 lb-force (110 N)	
	Max Permissible Fitting Pressure	72 lb-force (320 N)	72 lb-force (320 N)	72 lb-force (320 N)	
Weight	Gearbox Only	14.3 oz (406 gm)	17.9 oz (508 gm)	21.5 oz (609 gm)	
	Gearbox w/NEMA Flange	14.8 oz (420 gm)	18.5 oz (525 gm)	22.2 oz (630 gm)	

		NEMA 17 Motor	Size 1713	Size 1715	Size 1719
Length Inches (mm)	L _{MAX1}	1.34 (34.0)	1.57 (40.0)	1.89 (48.0)	
	L _{MAX2} w/Double Shaft	1.89 (48.0)	2.13 (54.0)	2.44 (62.0)	

P52 Planetary Gearbox with Size 23 Stepping Motor

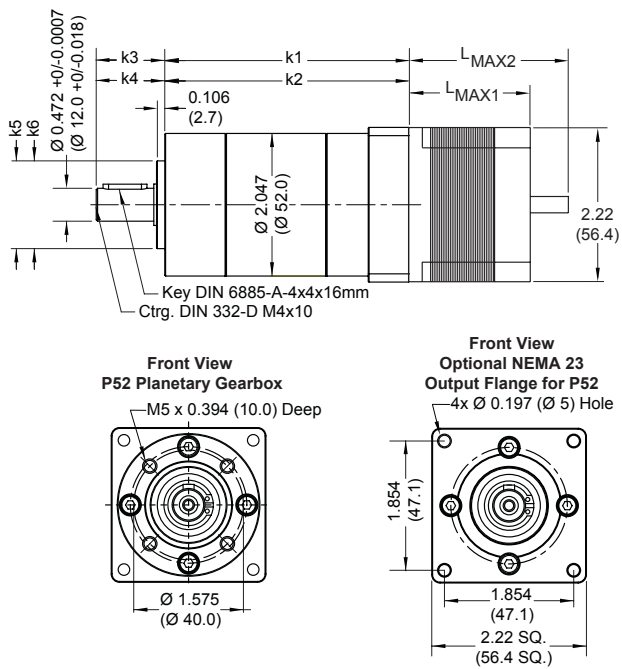

		Planetary Gearbox	1-Stage	2-Stage	3-Stage
Dimensions Inches (mm)	k1	Standard Gearbox	2.976 (75.6) ±0.02 (0.5)	3.531 (89.7) ±0.02 (0.5)	4.087 (103.8) ±0.02 (0.5)
	k2	w/NEMA Flange	3.035 (77.1) ±0.02 (0.5)	3.590 (91.2) ±0.02 (0.5)	4.146 (105.3) ±0.02 (0.5)
	k3	Standard Shaft	0.984 (25.0)		
	k4	Shaft w/NEMA Flange	0.925 (23.5)		
	k5	Standard Locator Diameter	1.260 (32.0) +0/-0.0015 (+0/-0.039)		
	k6	Locator Diameter w/NEMA Flange	1.50 (38.1) +0/-0.0015 (+0/-0.039)		
Parameters	Max Output Torque	566 oz-in (4.0 Nm)	1699 oz-in (12.0 Nm)	3540 oz-in (25.0 Nm)	
	Efficiency	80 %	75 %	70 %	
	Max Backlash	0.70°	0.75°	0.80°	
Loads	Max Radial Load	45 lb-force (200 N)	72 lb-force (320 N)	101 lb-force (450 N)	
	Max Axial Load	13 lb-force (60 N)	22 lb-force (100 N)	34 lb-force (150 N)	
	Max Permissible Fitting Pressure	112 lb-force (500 N)	112 lb-force (500 N)	112 lb-force (500 N)	
Weight	Gearbox Only	25.0 oz (711 gm)	32.2 oz (914 gm)	39.4 oz (1117 gm)	
	Gearbox w/NEMA Flange	25.9 oz (735 gm)	33.3 oz (945 gm)	40.7 oz (1155 gm)	

		NEMA 23 Motor	Size 2218	Size 2222	Size 2231
Length Inches (mm)	L _{MAX1}	1.77 (45.0)	2.13 (54.0)	2.99 (76.0)	
	L _{MAX2} w/Double Shaft	2.32 (59.0)	2.68 (68.0)	3.54 (90.0)	

P81 Planetary Gearbox with Size 34 Stepping Motor

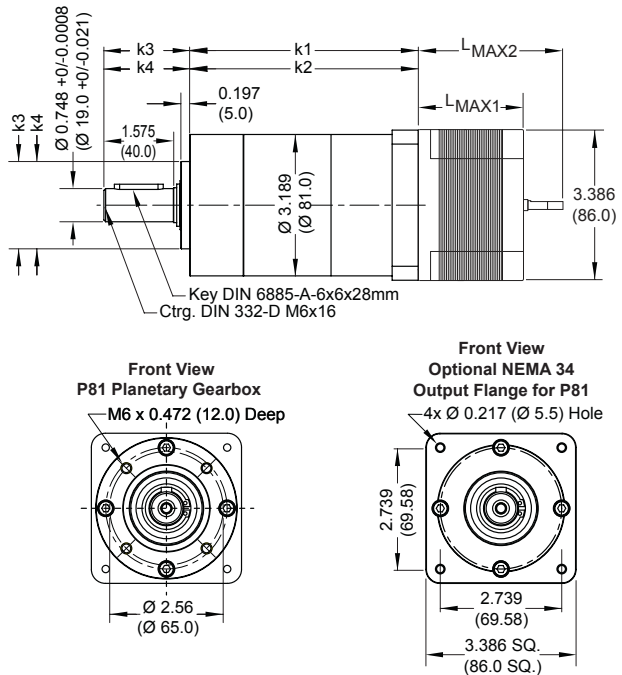

		Planetary Gearbox	1-Stage	2-Stage	3-Stage
Dimensions Inches (mm)	k1	Standard Gearbox	4.315 (109.6) ±0.02 (0.5)	5.169 (131.3) ±0.02 (0.5)	6.024 (153.0) ±0.02 (0.5)
	k2	w/NEMA Flange	4.433 (112.6) ±0.02 (0.5)	5.287 (134.3) ±0.02 (0.5)	6.142 (156.0) ±0.02 (0.5)
	k3	Standard Shaft	1.929 (49.0)		
	k4	Shaft w/NEMA Flange	1.811 (46.0)		
	k5	Standard Locator Diameter	1.969 (50.0) +0.0006/-0.0004 (+0.015/-0.010)		
	k6	Locator Diameter w/NEMA Flange	2.874 (73.0) +0/-0.0012 (+0/-0.030)		
Parameters	Max Output Torque	2832 oz-in (20.0 Nm)	8496 oz-in (60.0 Nm)	16992 oz-in (120.0 Nm)	
	Efficiency	80 %	75 %	70 %	
	Max Backlash	1.0°	1.5°	2.0°	
Loads	Max Radial Load	90 lb-force (400 N)	135 lb-force (600 N)	225 lb-force (1000 N)	
	Max Axial Load	18 lb-force (80 N)	27 lb-force (120 N)	45 lb-force (200 N)	
	Max Permissible Fitting Pressure	337 lb-force (1500 N)	337 lb-force (1500 N)	337 lb-force (1500 N)	
Weight	Gearbox Only	64.4 oz (1827 gm)	89.5 oz (2538 gm)	114.6 oz (3248 gm)	
	Gearbox w/NEMA Flange	66.7 oz (1890 gm)	92.6 oz (2625 gm)	118.5 oz (3360 gm)	

		NEMA 34 Motor	Size 3424	Size 3431	Size 3447
Length Inches (mm)	L _{MAX1}	2.36 (60.0)	3.15 (80.0)	4.72 (120.0)	
	L _{MAX2} w/Double Shaft	3.25 (82.5)	4.04 (102.5)	5.61 (142.5)	

Stepping Motor with Planetary Gearbox: Installing a Driving Device



WARNING! When installing a gear, pulley, coupling or other driving device to the Output Shaft of the Planetary Gearbox, IMS recommends that it be "slip-fit" to the shaft and properly secured, i.e. with set screws.

On some applications it may be necessary to press-fit a gear, pulley, coupling or other driving device onto the Output Shaft of the Planetary Gearbox. If your application requires that the driving device must be press-fit, the warnings and notes below must be observed.

NEVER tap or hammer a driving device onto the Output Shaft of the Planetary Gearbox

NEVER exceed the specified Maximum Permissible Fitting Pressure of the Planetary Gearbox.

CAUTION! The Stepping Motor can withstand the Maximum Permissible Fitting Pressure of the Planetary Gearbox if properly supported around the perimeter with the following exception: On some Stepping Motors with Encoders the perimeter of the motor is not accessible.

WARNING! Disconnecting the Planetary Gearbox from the Stepping Motor may void the Warranty.