

Transforming machine design: the power of integrated motion control

Reducing machine size, cost and complexity
by using integrated motion control



Transforming machine design: the power of integrated motion control

Reducing machine size, cost and complexity by using integrated motion control

Abstract

Today's rapidly evolving industrial climate demands machines that are compact, inexpensive and easy-to-use. The system integrator is placed in the position of providing the marketplace with machines that meet these criteria quickly. By implementing an integrated motion control solution, system integrators and OEMs can deliver more reliable machines that are smaller, more affordable and less complex. This can be accomplished with the added benefit of reducing their time-to-market.

The Challenge

System integrators and OEMs are faced with the challenge of designing machines that are more compact, less expensive and more reliable. This is a challenge that is greatly impacted by the components available to design into the machine. In the motion control industry this means components such as stand-alone indexers, PC based motion controllers or PLCs, stepping or servo motor drives, motors, accessories such as encoders, resolvers, limit and home switches, proximity sensors, light curtains and cable harnesses as well as all the associated mounting hardware.

Machine size

Space is money. The smaller the machine the greater the utilization of available space on a factory floor or laboratory bench. For the potential buyers of a piece of machinery, the cabinet size and floor footprint of the machine is a consideration that they must take into account.

Another consideration is the cost and complexity of transporting the machine to the end-user. Larger machines may require a field service representative to be on-site to perform or oversee the assembly, setup, programming and startup of the machine. The larger and more complex a machine, the greater chance of problems requiring time to troubleshoot and repair by field service staff during the initial setup.

Machine cost

There are three basic factors impacting the cost to design and manufacture a machine:

1. **Cost of components:** The greater number of components that are designed into a machine impact the cost of the machine. Additionally, a large number of components also means a large inventory of repair/replacement parts.
2. **Cost of labor:** A large number of components in a system require expensive skilled labor in mounting components and cable harnessing.
3. **Time-to-market:** The time-to-market and development cost factor has two facets. First is the design cycle. A significant portion of time spent engineering a machine is spent in specifying components and validating that these components, often from different manufacturers, will inter-operate seamlessly. Second is the manufacturing cycle. The time it takes from the moment the machine enters the assembly process to the time it rolls off the factory floor is an important cost factor in manufacturing the machine.

Machine complexity

Greater complexity in a machine brings its own set of problems.

1. Longer design cycle: more time and money is spent researching and purchasing components, debugging compatibility issues between components, and electrical noise in wire harnessing systems.
2. The more complex a machine, the greater the number of potential failure points in the system. This decreases the overall reliability of the system and increases the potential for a greater amount of post-sales support and field service calls.
3. The more complex a machine, the more difficult and time-consuming it is to manufacture.

This white paper will explore the advantages of implementing an integrated motion control solution into machine design saving the system integrator and OEMs cabinet space, money and time through the use of a single standard motion system component instead of separate system components.

The Solution: Integrated Motion Control

By implementing an integrated motion control solution the system integrator is able to reduce the size, cost and complexity of a machine by replacing several components with a single integrated component. A standard motion system consists of:

1. Controller or PLC
2. Power supplies for the drive and control electronics
3. Driver
4. Motor
5. Cable harnessing
6. Accessories such as encoders, limit and home switches, proximity sensors, etc.

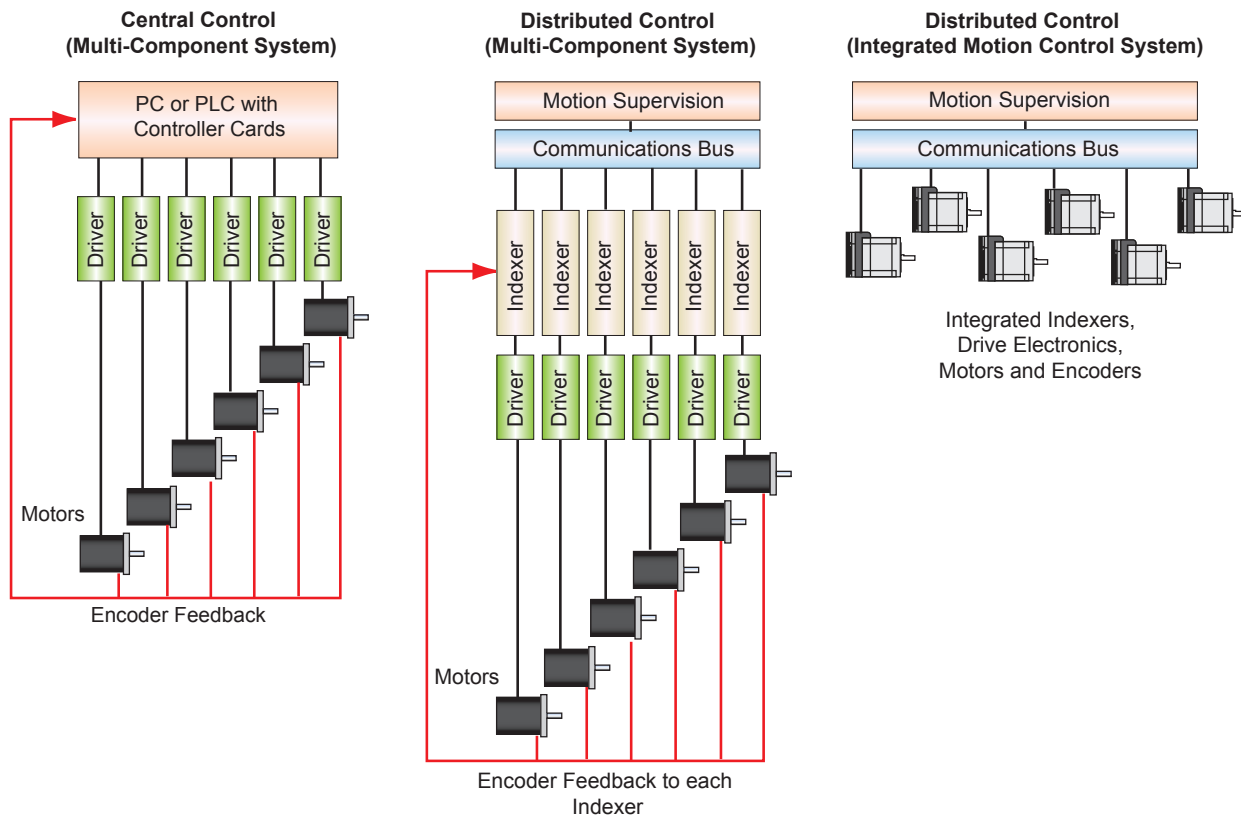

Figure: Central and Distributed Control Systems showing the Reduced Complexity of an Integrated Solution

How an integrated motion control solution can **reduce machine size**

Integrated motion control solutions for machine design are able to significantly reduce the amount of space required for a machine by consolidating components, eliminating cabling and, possibly, an entire enclosure (in a component based motion control system, the control electronics and drivers are often contained in separate electronics enclosures).

Integration can bring all of these separate components into one single piece, reducing the required panel space significantly. In the case of multi-axis systems, this can lead to a substantial reduction in the real estate required for the end product.

Smaller machines are also easier to deliver to the final destination. Instead of field service representatives on-site for the setup and programming of the machine, it may be possible to preprogram and ship the machine, with setup performed prior to shipping or by the end-user.

How an integrated motion control solution can **reduce machine cost**

1. **Cost of components:** In some cases, an integrated solution may be less expensive than even a single piece in a multi-component solution. In repair parts replacement, as well as assembly stock, instead of storing multiple components in inventory, only one is required. For an OEM building and supporting hundreds of machines annually, this cost savings can be significant.
2. **Cost of labor:** In the multi-component solution, each component must be mounted into an enclosure, with wire and cabling run between the various components. With the motor, drive and control electronics (and in cases the motor power supply) in a single package in the integrated solution, the control electronics are very near the axis load. This means much shorter cable runs between accessories such as encoders, limit and home switches and the control cabinet. By implementing an integrated solution, the assembly labor can be reduced to mounting and interfacing a single component.
3. **Time-to-market:** Integrated motion solutions can reduce the time-to-market in two areas: the *design cycle* and the *manufacturing time*. The *design cycle* is reduced in two ways. With an integrated motion solution, only one component needs to be specified and integrated into the system. Additionally, reduced cabling limits electrical noise issues with prototype machines. The *manufacturing time* is also reduced because, as previously noted, much less assembly is required.

How an integrated motion control solution can **reduce machine complexity**

1. By using an integrated solution, engineering staff can spend more time developing machines and less time solving compatibility issues between various system components. With an integrated motion solution, the integrated components have already been designed and sized for function as a complete unit.
2. By reducing the number of components in a system, and thus the number of wire connections, the overall reliability of the machine is increased. This equates to fewer service calls, which also means less potential downtime for the customer.

Summary

Integrated motion control solutions can be implemented into machine designs to reduce the size, cost and complexity of a machine. The advantages of integrated motion control include:

- Compact design
- Low cost
- Ease of system integration
- High reliability

Industry demand for smaller, less expensive, and more flexible machines is only going to increase. Integrated motion control is a solution that is transforming machine design practices.

To learn more about the advantages of integrated motion control visit www.schneider-electric-motion.us.

Schneider Electric Motion USA

370 North Main Street, P.O. Box 457
Marlborough, CT 06447 - U.S.A.
Tel. +00 (1) 860 295-6102 - Fax +00 (1) 860 295-6107
e-mail: info@imshome.com
www.schneider-electric-motion.us

© Schneider Electric Motion USA All rights reserved. REV010810
Product Disclaimer and most recent product information online

IMS
INTELLIGENT MOTION
SYSTEMS, INC.

Schneider
Electric