

## Quick Reference **Anti-backlash nut** Installation, removal and assembly

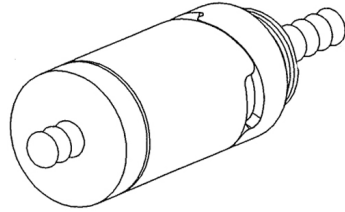

**IMS**  
INTELLIGENT MOTION  
SYSTEMS, INC.

**Schneider**  
Electric

### Notes and warnings

- Do not use a wrench on the stainless steel cam of the nut.
- Do not oil the mechanism of the nut.
- Do not install the nut into an interference fit bore (mechanism will not work).

### Installation

To install threaded model nuts, simply hand tighten until shoulder is flush with mounting surface. A small amount of Loctite thread compound such as #277 can be used to prevent loosening. Alternatively, a pin can be installed to mechanically lock the threads.

Flanged models can be mounted to either the front or rear face of the flange.

Before use, it is recommended that the stainless steel preload mechanism be turned so that the camming surfaces move down the ramps. Once play is felt, allow the mechanism to slowly unwind again to establish the proper preload. (It is possible in assembly to inadvertently twist the cam creating excessive drag torque. This procedure will correct this.)

Using lubricant on the lead screw threads is recommended. This extends the life of the nut and reduces heat generation, noise and vibration. TriGEL-300S or TriGEL-1200SC is recommended.

### Removal from screw

If it is necessary to remove the nut from your screw, you may lock the mechanism so that it can be immediately reinstalled without re-setting the preload. This can be done by wrapping tape around the junction between the stainless steel cam and the plastic nut halves. This will prevent the cam from turning when the nut is removed from screw. Remember to remove tape after installation.

For immediate transfer from one screw to another, hold the nut together between your thumb and forefinger so that it cannot expand axially. Remove the nut and install it on the second screw. It may be helpful to prevent the cam from turning with your remaining fingers as you transfer. If the nut becomes disassembled or loses its preload for any reason, follow the steps listed in the assembly procedure below.

### Assembly procedure

1. Insert spring tang into cam slot.

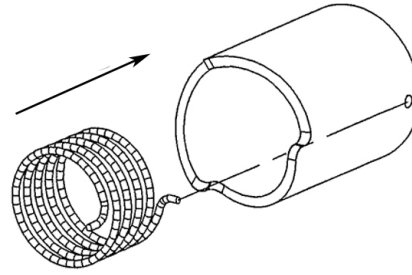

2. Ensure that the spring is engaged.

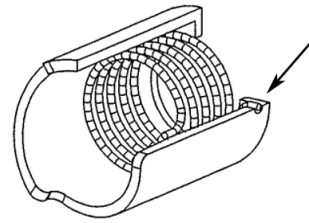

3. Insert opposite tang into front nut slot or hole (dependent on size). Use the slot or hole that will allow the cam to be positioned closest to the bottom of the ramp.

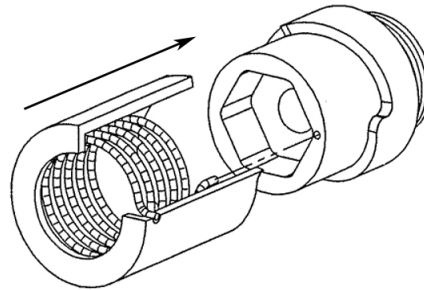

4. With washer installed, insert the back nut into the front nut.

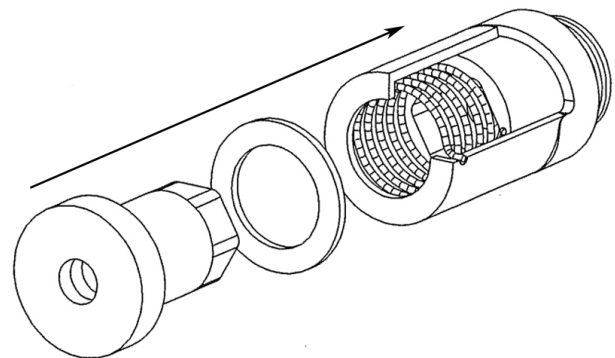

5. With the cam held at the bottom of the ramp, thread the entire nut onto the screw starting with the front nut. After the entire nut is threaded onto the screw, release the cam to observe the gap distance (X on the drawing). The gap distance (X) should be about one-third of the full ramp distance, but no more than half.

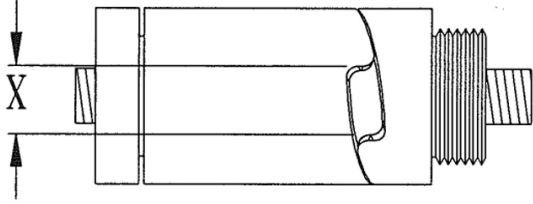

8. The anti-backlash nut is now pre-loaded and fully assembled.

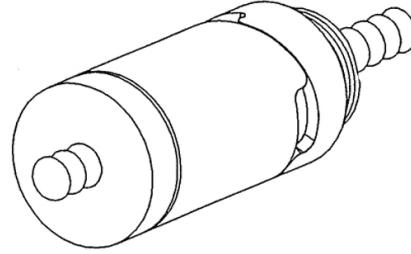

6. If the gap distance is incorrect, unthread the nut just enough to allow the back nut to disengage from the screw. Pull the back nut off and rotate to the next index position and reinsert back into the front nut. With the cam held at the bottom of the ramp, thread the entire nut back onto the screw. Release the cam and verify the correct gap distance. If still not correct repeat this step.

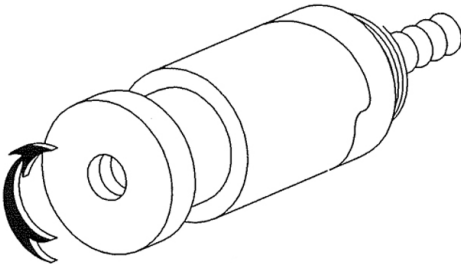

7. Once the back nut has been properly clocked to yield the correct gap distance, unthread the nut again just enough to disengage the back nut from the screw, but do not remove from the nut. Pull the cam away from the ramp and rotate in the clockwise direction for two ramp settings, then hold the cam at the bottom of the second ramp. Be careful not to allow the back nut to rotate with respect to the front nut while completing this task. With the cam held at the bottom of the second ramp, push the back nut into the front nut and thread the entire nut onto the screw.

