

Unwanted Circulating Currents with Motion Control units in Party Mode

Issue:

The MDrive Motion Control (MDI) units, when used in the Party Mode (RS422/485 Multidrop,) may have unwanted circulating currents in the common wire of the communication port. These unwanted currents may cause hardware failures or communication errors.

Root Cause:

The motor power supply input common (P2-6 or the black wire) is tied internally to the common (P1-10) of the communication port. When two or more Motion Control units are wired in the Party Mode (PY=1, RS 422/485 multidrop) a “ground loop” is created. The common wire that connects the communication ports is in parallel with the power common connections. Thus, some of the motor power current of one Motion Control unit could flow through its communication port and into the other unit’s communication port and visa versa (*see Figure 1*).

Solution:

This solution (*Figure 2*) eliminates the circulating currents by removing the communication’s common wires between the Motion Control units. One single common connection is still needed however, between the PC’s communication port and the MDrive’s power supply.

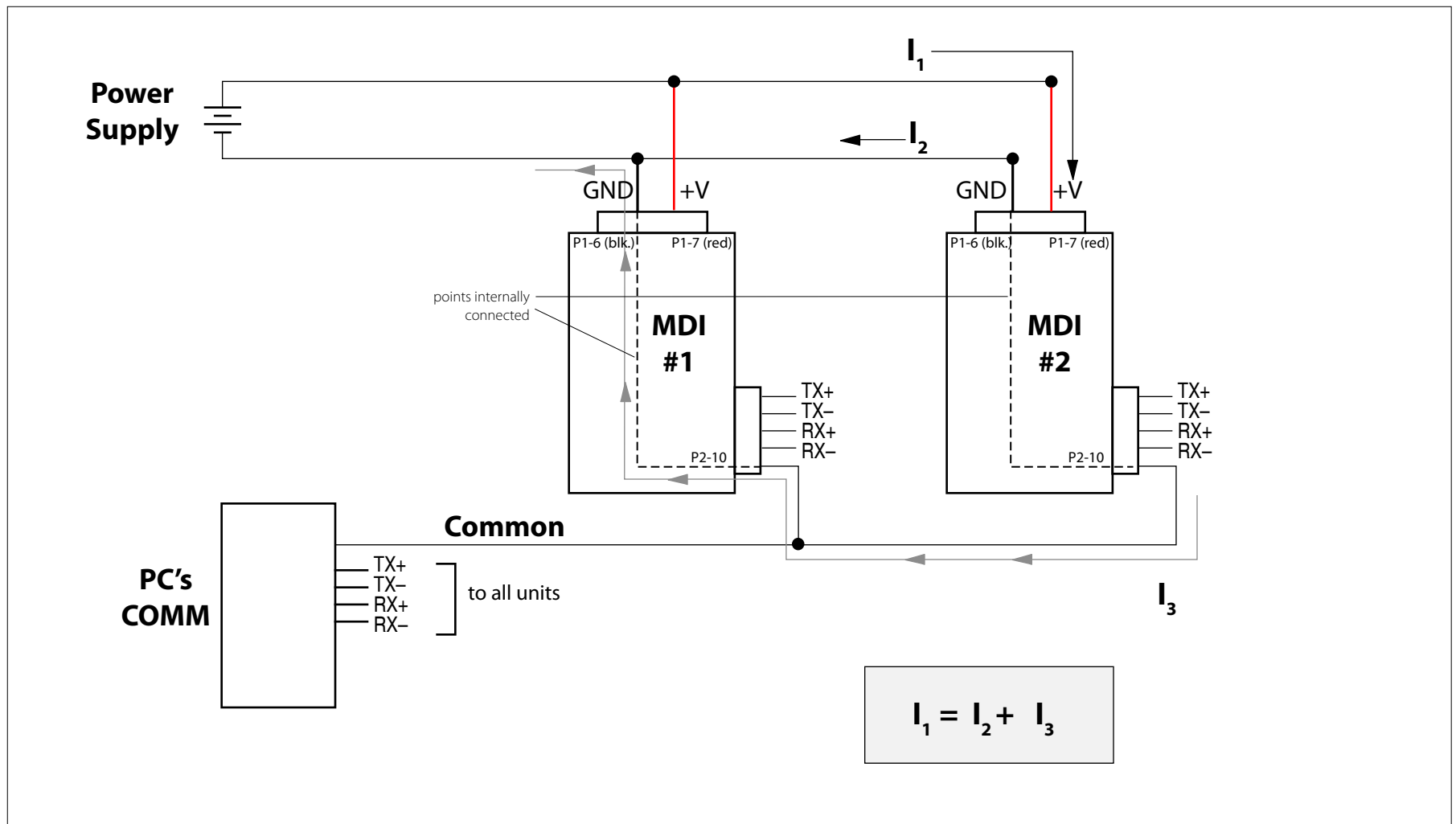

Figure 1

As is with circulating currents

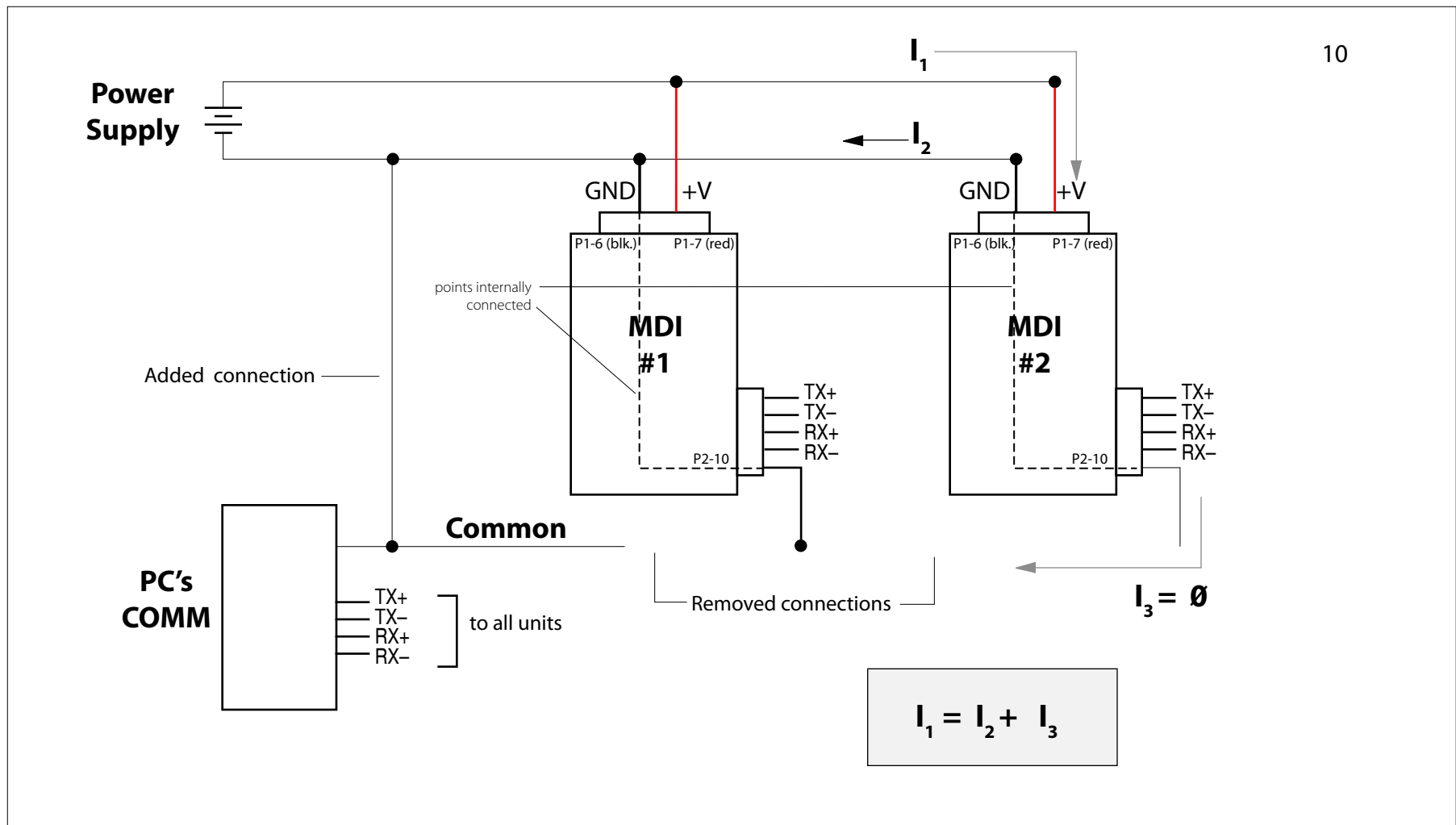

Figure 2

Solution:

*No circulating currents - snip #10 position wire between ribbon connectors.
Then connect the PC's communication common to the motor's power supply common.*