

Quick Reference **NEMA size 34 1.8°**
2-phase stepper motor

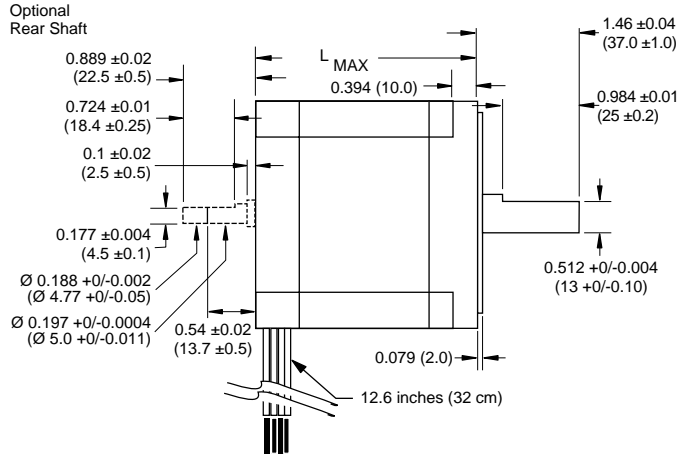

Mechanical Specifications
Dimensions in inches (mm)



FRONT VIEW

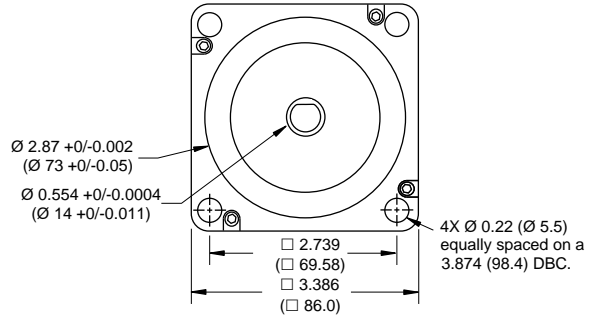

REAR VIEW (Reduced)

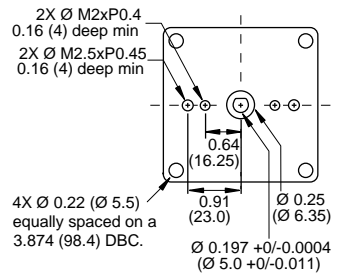

IMS
INTELLIGENT MOTION
SYSTEMS, INC.

Schneider
Electric

Notes and Warnings

- Installation, configuration and maintenance must be carried out by qualified technicians only. You must have detailed information to be able to carry out this work.
- Unexpected dangers may be encountered when working with this product!
 - Incorrect use may destroy this product and connected components!

Specifications

6.3 Amp motors		Single length	Double length	Triple length
Part number		M-3424-6.3 • (1)	M-3431-6.3 • (1)	M-3447-6.3 • (1)
Holding torque	oz-in	419	637	1203
	N-cm	296	450	920
Detent torque	oz-in	10.9	14.2	19.8
	N-cm	7.7	10.0	14.0
Rotor inertia	oz-in-sec ²	0.01416	0.02266	0.04815
	kg-cm ²	1.0	1.6	3.4
Weight	oz	60.0	84.7	141.1
	grams	1700	2400	4000
Phase current	amps	6.3	6.3	6.3
Phase resistance	ohms	0.25	0.35	0.50
Phase inductance	mH	1.6	3.3	6.6

(1) Indicate S for single-shaft or D for double-shaft. Example M-3424-6.3S

Motor stack length inches (mm)	Single	Double	Triple
LMAX	2.36 (60)	3.15 (80)	4.72 (120)

Wiring and Connections

Signals and wire colors	
Phase A	Black
Phase /A	Orange
Phase B	Red
Phase /B	Yellow

Part Numbers

Example:	M - 3 4 2 4 - 6 . 3 S
Stepper motor frame size	M - 3 4 2 4 - 6 . 3 S
M-34 = NEMA 34 (3.4"/86 mm)	
Motor length	M - 3 4 2 4 - 6 . 3 S
24 - = single stack	
31 - = double stack	
47 - = triple stack	
Phase current	M - 3 4 2 4 - 6 . 3 S
6.3 = 6.3 Amps	
Shaft	M - 3 4 2 4 - 6 . 3 S
S = single, front shaft only	
D = double, front and rear shafts	
Optional optical encoder (1)	M - 3 4 2 4 - 6 . 3 E S 1 0 0
ES = Single-end	
ED = Differential	
Line count	
100, 200, 250, 400, 500 or 1000 (2)	

(1) An encoder replaces the shaft designator in the part number.

(2) All encoders have an index mark, except the 1000 line count version.

Torque-speed performance
Measured at 6.3 amps RMS

M-3424-6.3

Torque in oz-in (N-cm)

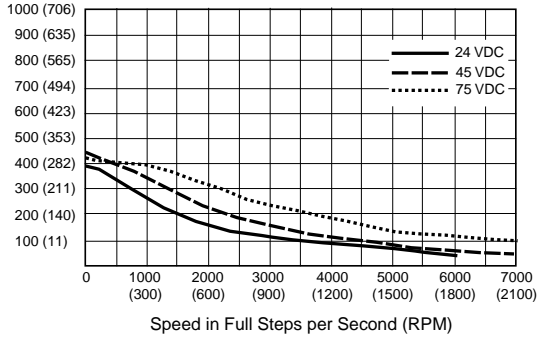

M-3431-6.3

Torque in oz-in (N-cm)

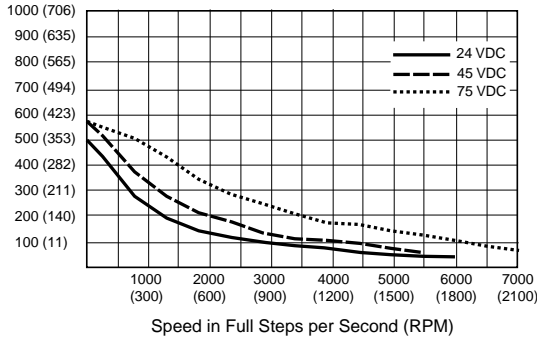

M-3447-6.3

Torque in oz-in (N-cm)

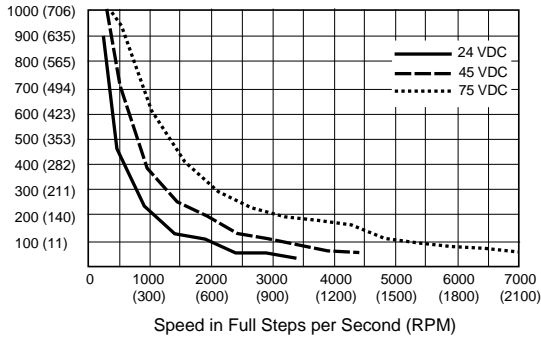

Optical Encoder Option

Dimensions in inches (mm)

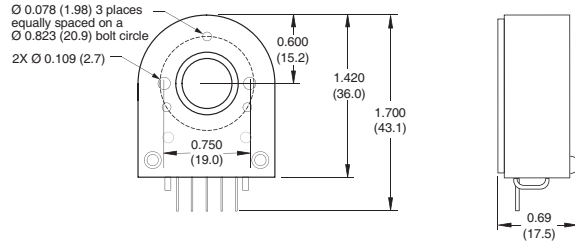

Connectivity **single-end encoder**

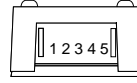

wire	function
1 Brown	Ground
2 Violet	Index
3 Blue	Channel A
4 Orange	+5 VDC input
5 Yellow	Channel B

optional interface cable available: ES-CABLE-2

differential encoder

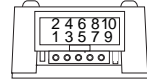

pin function	pin function
1 no connect	6 Channel A+
2 +5 VDC input	7 Channel B-
3 Ground	8 Channel B+
4 no connect	9 Index -
5 Channel A-	10 Index +

interface cable included

Timing

single-end encoder

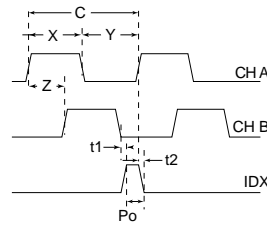

differential encoder

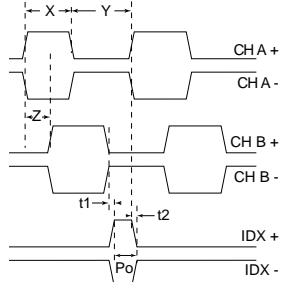

Parameter	Symbol	Min	Typ	Max	Units
Cycle error			3	5.5	°e
Symmetry		130	180	230	°e
Quadrature		40	90	140	°e
Index pulse width	Po	60	90	120	°e
Index rise (after Ch A or B rise)	t1	-300	100	250	ns
Index fall (after Ch A or B fall)	t2	70	150	1000	ns

C One cycle: 360 electrical degrees (°e).
 X/Y Symmetry: the measure of the relationship between X and Y, nominally 180°e.
 Z Quadrature: the phase lead or lag between channels A and B, nominally 90°e.
 Po Index pulse width, nominally 90°e.
 NOTE: Rotation is as viewed from the cover side of the encoder.